

Dist	COUNTY	ROUTE	POST MILES TOTAL PROJECT	SHEET No.	TOTAL SHEETS
04	Ala, CC	680	R11.0/R21.9, RO.0/RO.9	701	1710

REGISTERED CIVIL ENGINEER *Erin D. McPherson* DATE 9-29-21
 October 8, 2021
 PLANS APPROVAL DATE

ERIN D. McPHERSON
 No. C91111
 Exp. 3-31-24
 CIVIL
 STATE OF CALIFORNIA

THE STATE OF CALIFORNIA OR ITS OFFICERS OR AGENTS SHALL NOT BE RESPONSIBLE FOR THE ACCURACY OR COMPLETENESS OF SCANNED COPIES OF THIS PLAN SHEET.

WMH CORPORATION 55 South Market St Suite 1200 San Jose, CA 95113	ALAMEDA CTC 1111 Broadway Suite 800 Oakland, CA 94607
---	--

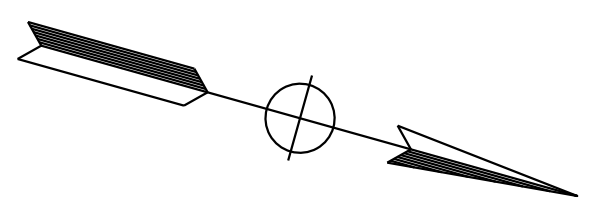

NOTE:
FOR ACCURATE RIGHT OF WAY DATA, CONTACT RIGHT OF WAY ENGINEERING AT THE DISTRICT OFFICE.

DESIGNED BY	JV	DATE	9-29-21
REVISOR		DATE	
CHECKED BY	ERIN McPHERSON		
DESIGNED BY	JAMEY VALDIVIA		
CONSULTANT SUPERVISOR	TIMOTHY J. LEE		
FUNCTIONAL SUPERVISOR			
DESIGNED BY	JAMEY VALDIVIA		
CHECKED BY	ERIN McPHERSON		

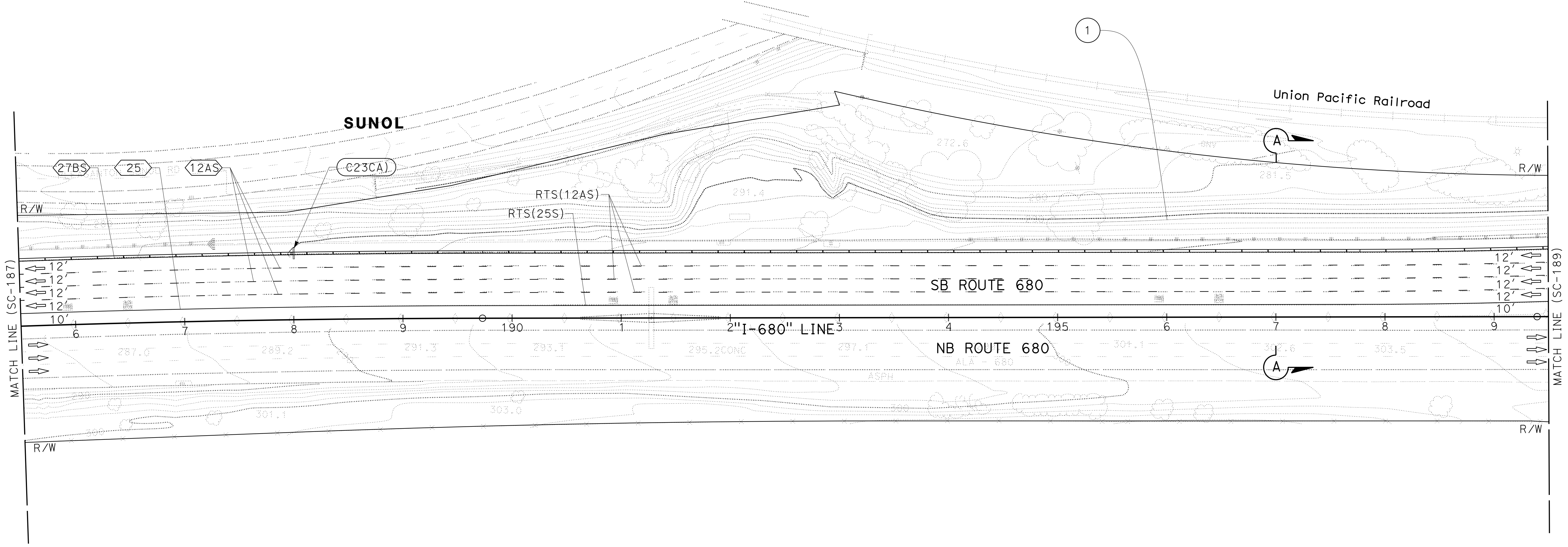

FOR NOTES, ABBREVIATIONS AND LEGEND, SEE SHEET SC-1 AND SC-186

APPROVED FOR STAGE CONSTRUCTION AND TRAFFIC HANDLING WORK ONLY

STAGE CONSTRUCTION AND TRAFFIC HANDLING PLAN STAGE 4

SCALE: 1" = 50'

SC-188

LAST REVISION: 09-29-21 11:53 AM
 DATE PLOTTED: 09-29-21 11:53 AM
 TIME PLOTTED: 09-29-21 11:53 AM

X:\680_SB_EXPRESS\000_CAD\Submit\11\11\CADD_sub\11\11\0420000235ma1189.dgn
 STATE OF CALIFORNIA - DEPARTMENT OF TRANSPORTATION
 CONSULTANT FUNCTIONAL SUPERVISOR
 JAMES VALDIVIA
 ERIN MCPHERSON
 TIMOTHY J. LEE
 REVISIONS:
 REVISED BY: JAV
 DATE REVISED: 9-29-21
 CALCULATED/DESIGNED BY: JAV
 CHECKED BY: ERIN MCPHERSON

NOTE:
 FOR ACCURATE RIGHT OF WAY DATA, CONTACT
 RIGHT OF WAY ENGINEERING AT THE DISTRICT OFFICE.

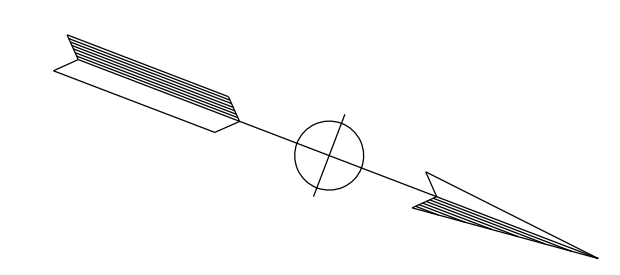

Dist	COUNTY	ROUTE	POST MILES TOTAL PROJECT	SHEET No.	TOTAL SHEETS
04	Ala, CC	680	R11.0/R21.9, R0.0/R0.9	702	1710

REGISTERED CIVIL ENGINEER: *Erin D. McPherson*
 DATE: 9-29-21
 PLANS APPROVAL DATE: October 8, 2021

REGISTERED PROFESSIONAL ENGINEER
 ERIN D. MCPHERSON
 No. C91111
 Exp. 3-31-24
 CIVIL
 STATE OF CALIFORNIA

THE STATE OF CALIFORNIA OR ITS OFFICERS OR AGENTS SHALL NOT BE RESPONSIBLE FOR THE ACCURACY OR COMPLETENESS OF SCANNED COPIES OF THIS PLAN SHEET.

WMH CORPORATION 55 South Market St Suite 1200 San Jose, CA 95113	ALAMEDA CTC 1111 Broadway Suite 800 Oakland, CA 94607
---	--

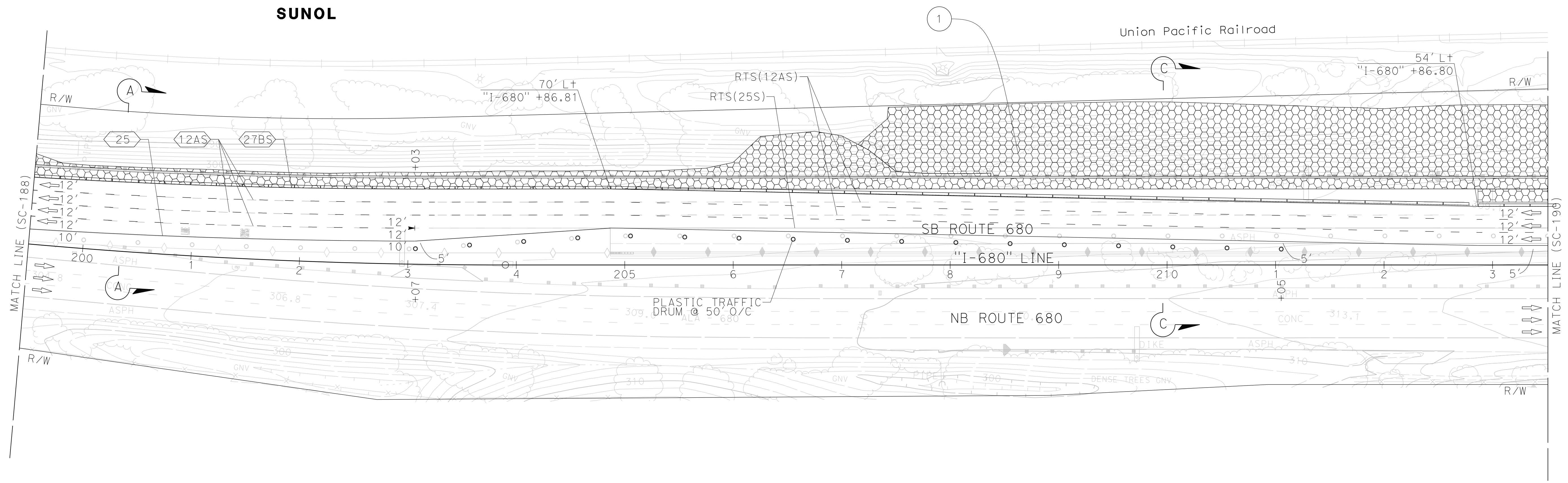

FOR NOTES, ABBREVIATIONS AND
 LEGEND, SEE SHEET SC-1 AND SC-186

APPROVED FOR STAGE CONSTRUCTION AND TRAFFIC HANDLING WORK ONLY

**STAGE CONSTRUCTION
 AND TRAFFIC HANDLING PLAN
 STAGE 4**

SCALE: 1" = 50'

SC-189

LAST REVISION: 09-29-21 DATE PLOTTED => 3/21/2022 TIME PLOTTED => 4:12:02 PM

X:\680_SB_EXPRESS\000_CAD\Submittal\10420000235ma190.dgn
 STATE OF CALIFORNIA - DEPARTMENT OF TRANSPORTATION
 CONSULTANT FUNCTIONAL SUPERVISOR: TIMOTHY J. LEE
 CALCULATED/DESIGNED BY: JAMEY VALDIVIA
 CHECKED BY: ERIN MCPHERSON
 REVISED BY: J.V.
 DATE REVISED: 9-29-21

NOTE:
 FOR ACCURATE RIGHT OF WAY DATA, CONTACT
 RIGHT OF WAY ENGINEERING AT THE DISTRICT OFFICE.

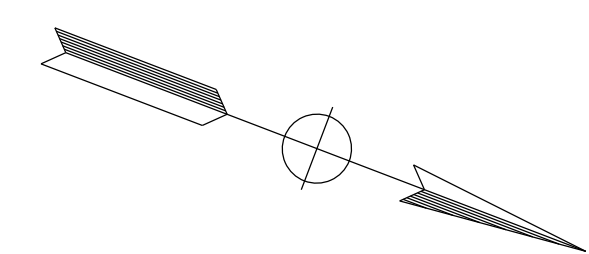

Dist	COUNTY	ROUTE	POST MILES TOTAL PROJECT	SHEET No.	TOTAL SHEETS
04	Ala, CC	680	R11.0/R21.9, RO.0/RO.9	703	1710
			9-29-21		
REGISTERED CIVIL ENGINEER			DATE		
October 8, 2021			PLANS APPROVAL DATE		
THE STATE OF CALIFORNIA OR ITS OFFICERS OR AGENTS SHALL NOT BE RESPONSIBLE FOR THE ACCURACY OR COMPLETENESS OF SCANNED COPIES OF THIS PLAN SHEET.					
WMH CORPORATION 55 South Market St Suite 1200 San Jose, CA 95113			ALAMEDA CTC 1111 Broadway Suite 800 Oakland, CA 94607		

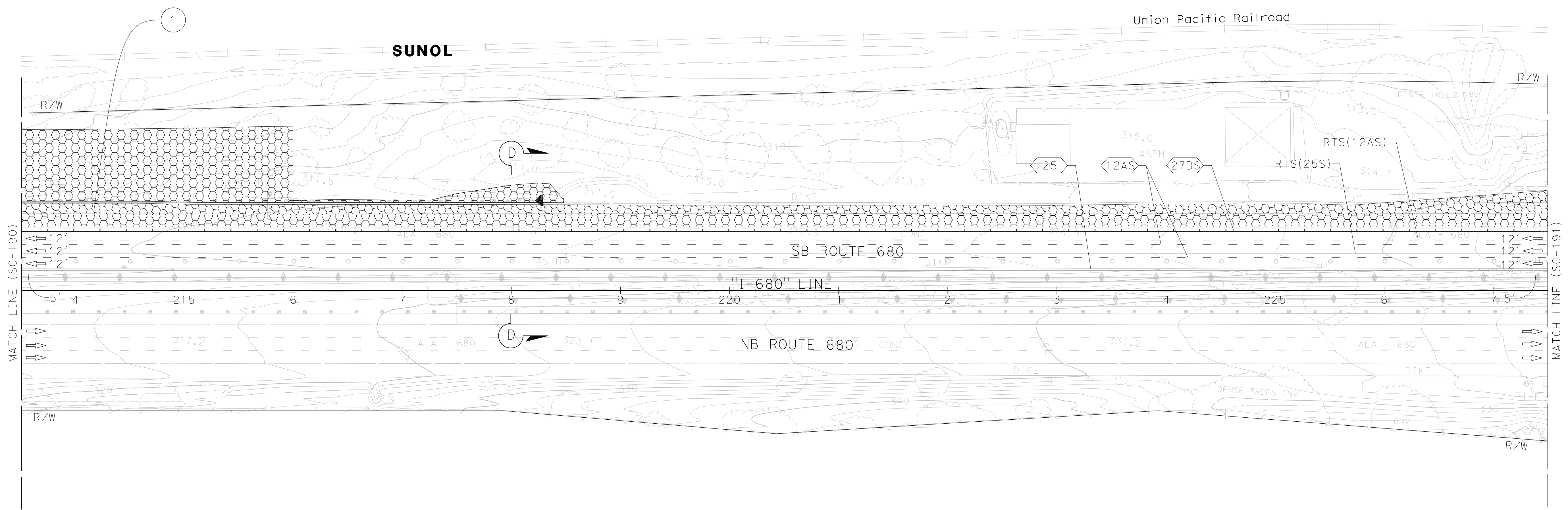

FOR NOTES, ABBREVIATIONS AND
 LEGEND, SEE SHEET SC-1 AND SC-186

APPROVED FOR STAGE CONSTRUCTION AND TRAFFIC HANDLING WORK ONLY

STAGE CONSTRUCTION AND TRAFFIC HANDLING PLAN STAGE 4

SCALE: 1" = 50'

SC-190

Dist	COUNTY	ROUTE	POST MILES TOTAL PROJECT	SHEET No.	TOTAL SHEETS
04	Ala, CC	680	R11.0/R21.9, R0.0/R0.9	704	1710
			9-29-21		
REGISTERED CIVIL ENGINEER			DATE		
October 8, 2021			PLANS APPROVAL DATE		
<small>THE STATE OF CALIFORNIA OR ITS OFFICERS OR AGENTS SHALL NOT BE RESPONSIBLE FOR THE ACCURACY OR COMPLETENESS OF SCANNED COPIES OF THIS PLAN SHEET.</small>					
WMH CORPORATION 55 South Market St Suite 1200 San Jose, CA 95113			ALAMEDA CTC 1111 Broadway Suite 800 Oakland, CA 94607		

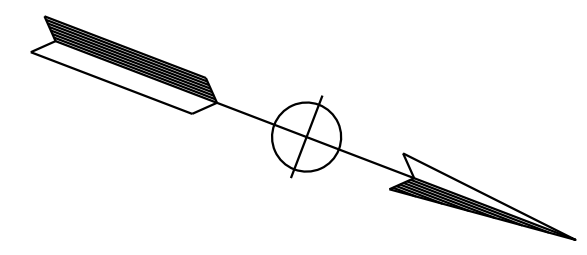

NOTE:
FOR ACCURATE RIGHT OF WAY DATA, CONTACT
RIGHT OF WAY ENGINEERING AT THE DISTRICT OFFICE.

REVISOR	DATE	REVISION
JV	9-29-21	
CALCULATED/DESIGNED BY: JAMEY VALDIVIA CHECKED BY: ERIN MCPHERSON CONSULTANT SUPERVISOR: TIMOTHY J. LEE		
STATE OF CALIFORNIA - DEPARTMENT OF TRANSPORTATION 		

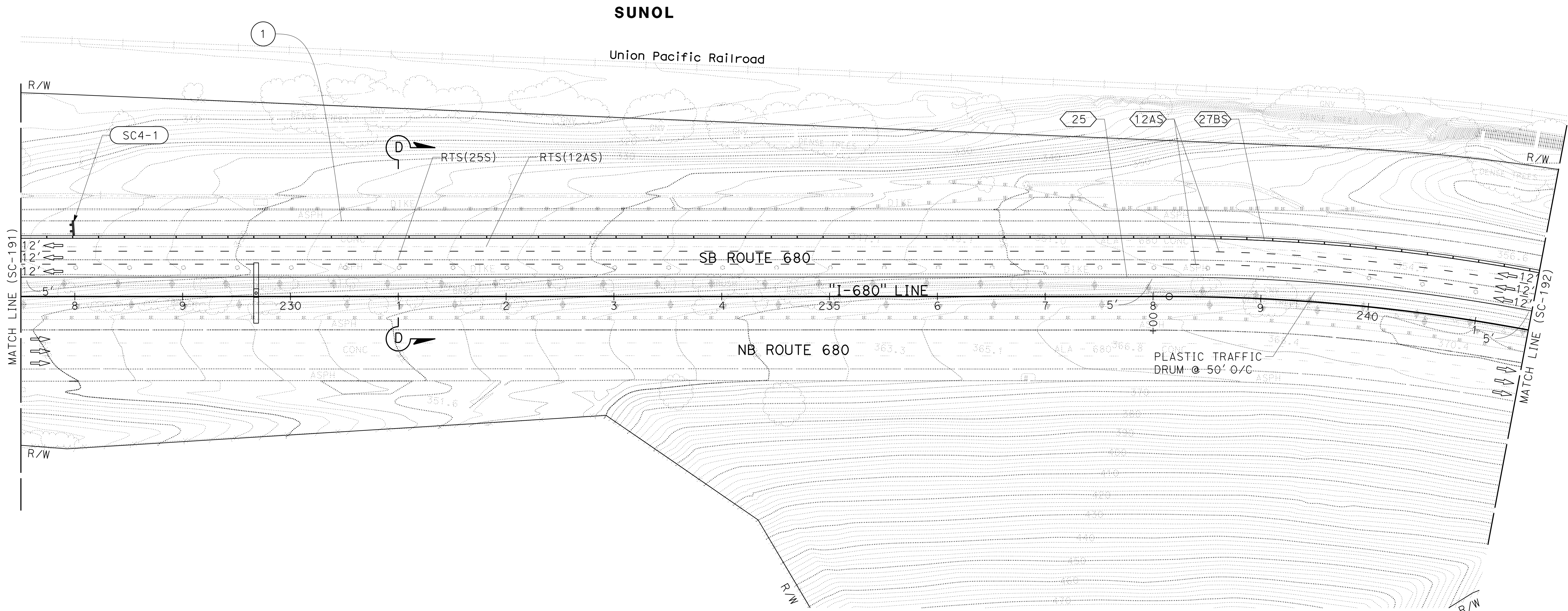

FOR NOTES, ABBREVIATIONS AND
LEGEND, SEE SHEET SC-1 AND SC-186

APPROVED FOR STAGE CONSTRUCTION AND TRAFFIC HANDLING WORK ONLY

**STAGE CONSTRUCTION
AND TRAFFIC HANDLING PLAN
STAGE 4**

SCALE: 1" = 50'

SC-191

LAST REVISION: DATE PLOTTED => 7-MAR-2022 TIME PLOTTED => 11:53

Dist	COUNTY	ROUTE	POST MILES TOTAL PROJECT	SHEET No.	TOTAL SHEETS
04	Ala, CC	680	R11.0/R21.9, R0.0/R0.9	705	1710
			9-29-21		
REGISTERED CIVIL ENGINEER			DATE		
October 8, 2021			PLANS APPROVAL DATE		
WMH CORPORATION 55 South Market St Suite 1200 San Jose, CA 95113			ALAMEDA CTC 1111 Broadway Suite 800 Oakland, CA 94607		

NOTE:
FOR ACCURATE RIGHT OF WAY DATA, CONTACT
RIGHT OF WAY ENGINEERING AT THE DISTRICT OFFICE.

REVISOR	DATE	REVISION
JV	9-29-21	
CALCULATED-DESIGNED BY: JAMEY VALDIVIA CHECKED BY: ERIN MCPHERSON CONSULTANT: TIMOTHY J. LEE SUPERVISOR:		

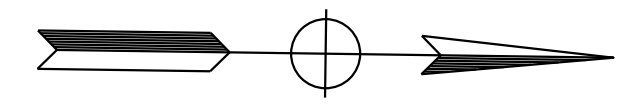

SUNOL

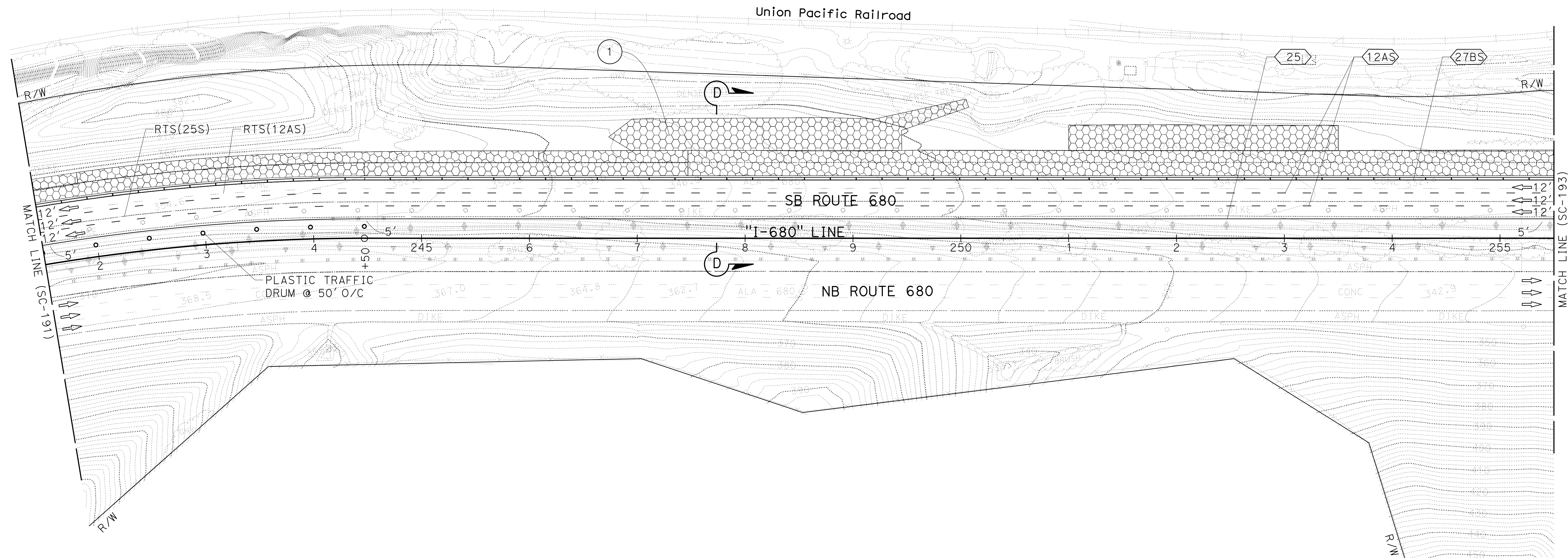

**STAGE CONSTRUCTION
AND TRAFFIC HANDLING PLAN
STAGE 4**

SCALE: 1" = 50'

SC-192

FOR NOTES, ABBREVIATIONS AND
LEGEND, SEE SHEET SC-1 AND SC-186

APPROVED FOR STAGE CONSTRUCTION AND TRAFFIC HANDLING WORK ONLY

LAST REVISION: 09-29-21 DATE PLOTTED => 7-MAR-2022 TIME PLOTTED => 11:53

Dist	COUNTY	ROUTE	POST MILES TOTAL PROJECT	SHEET No.	TOTAL SHEETS
04	Ala, CC	680	R11.0/R21.9, R0.0/R0.9	706	1710
			9-29-21		
REGISTERED CIVIL ENGINEER			DATE		
October 8, 2021			PLANS APPROVAL DATE		
WMH CORPORATION 55 South Market St Suite 1200 San Jose, CA 95113			ALAMEDA CTC 1111 Broadway Suite 800 Oakland, CA 94607		

NOTE:
FOR ACCURATE RIGHT OF WAY DATA, CONTACT
RIGHT OF WAY ENGINEERING AT THE DISTRICT OFFICE.

REVISOR	DATE	REVISION
JV	9-29-21	
REVISOR	DATE	REVISION
JAMIE VALDIVIA		
ERIN MCPHERSON		
CALCULATED- DESIGNED BY	CHECKED BY	
TIMOTHY J. LEE		
CONSULTANT FUNCTIONAL SUPERVISOR		
DEPARTMENT OF TRANSPORTATION		
STATE OF CALIFORNIA		

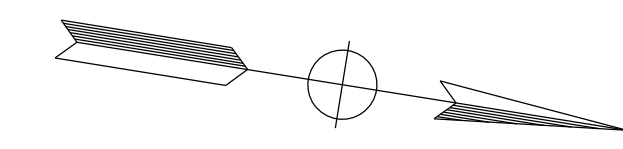
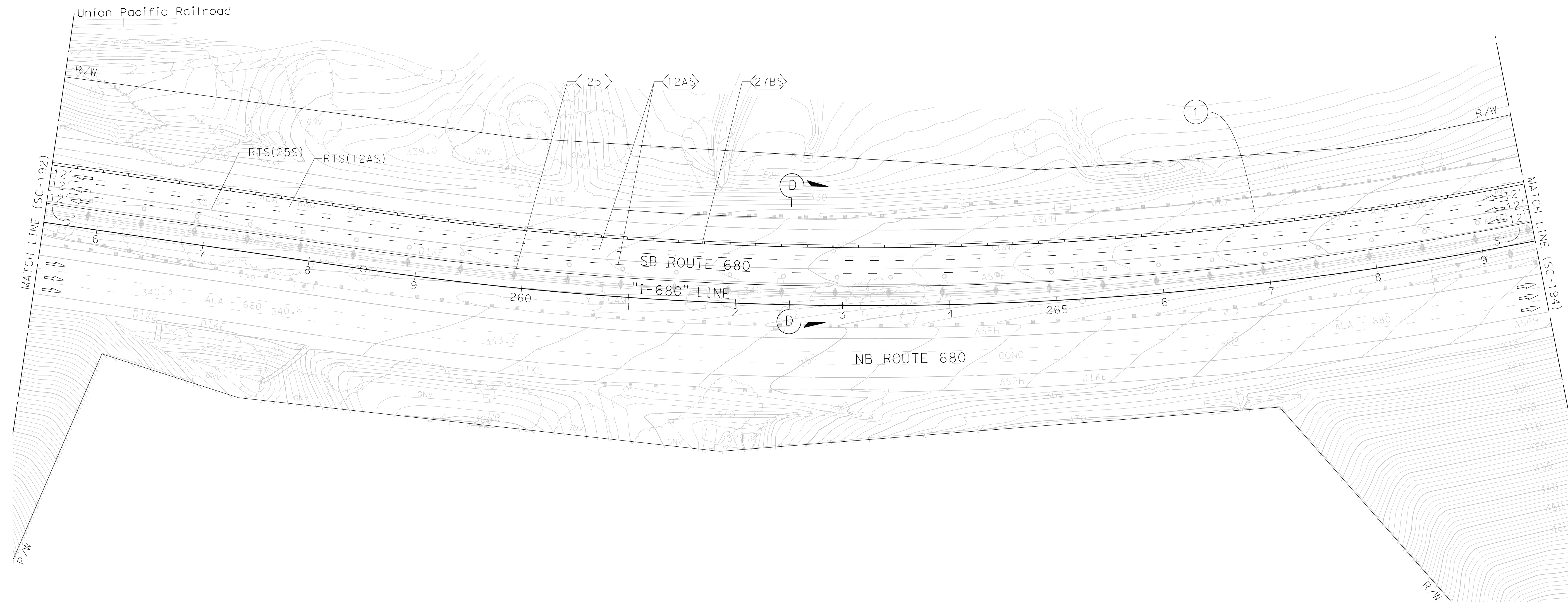

STAGE CONSTRUCTION AND TRAFFIC HANDLING PLAN STAGE 4

SCALE: 1" = 50'

SC-193

FOR NOTES, ABBREVIATIONS AND
LEGEND, SEE SHEET SC-1 AND SC-186

APPROVED FOR STAGE CONSTRUCTION AND TRAFFIC HANDLING WORK ONLY

LAST REVISION DATE PLOTTED => 3/21/2022 09-29-21 TIME PLOTTED => 4:12:24 PM

Dist	COUNTY	ROUTE	POST MILES TOTAL PROJECT	SHEET No.	TOTAL SHEETS
04	Ala, CC	680	R11.0/R21.9, RO.0/RO.9	707	1710
			9-29-21		
REGISTERED CIVIL ENGINEER <i>Erin D. McPherson</i>			DATE		
			October 8, 2021		
			PLANS APPROVAL DATE		
THE STATE OF CALIFORNIA OR ITS OFFICERS OR AGENTS SHALL NOT BE RESPONSIBLE FOR THE ACCURACY OR COMPLETENESS OF SCANNED COPIES OF THIS PLAN SHEET.					
WMH CORPORATION 55 South Market St Suite 1200 San Jose, CA 95113			ALAMEDA CTC 1111 Broadway Suite 800 Oakland, CA 94607		

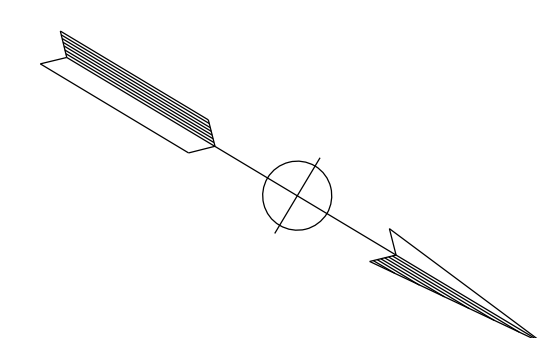

NOTE:
FOR ACCURATE RIGHT OF WAY DATA, CONTACT
RIGHT OF WAY ENGINEERING AT THE DISTRICT OFFICE.

CALCULATED-DESIGNED BY	JAMIEY VALDIVIA
CHECKED BY	ERIN MCPHERSON
FUNCTIONAL SUPERVISOR	TIMOTHY J. LEE
CONSULTANT	DEPARTMENT OF TRANSPORTATION
STATE OF CALIFORNIA	DEPARTMENT OF TRANSPORTATION

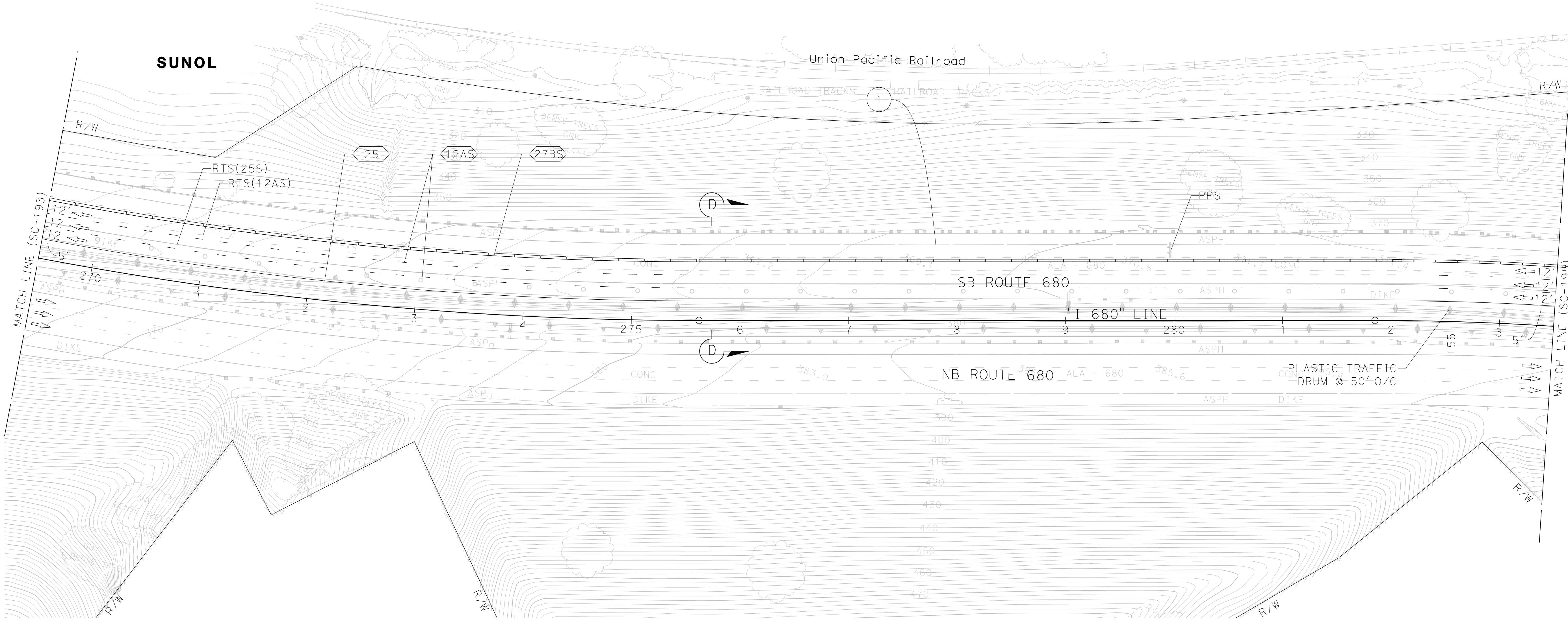

FOR NOTES, ABBREVIATIONS AND
LEGEND, SEE SHEET SC-1 AND SC-186

APPROVED FOR STAGE CONSTRUCTION AND TRAFFIC HANDLING WORK ONLY

STAGE CONSTRUCTION AND TRAFFIC HANDLING PLAN STAGE 4

SCALE: 1" = 50'

SC-194

LAST REVISION DATE PLOTTED => 3/21/2022 09-29-21 TIME PLOTTED => 4:12:29 PM

Dist	COUNTY	ROUTE	POST MILES TOTAL PROJECT	SHEET No.	TOTAL SHEETS
04	Ala, CC	680	R11.0/R21.9, RO.0/RO.9	708	1710
			9-29-21		
REGISTERED CIVIL ENGINEER			DATE		
October 8, 2021			PLANS APPROVAL DATE		
WMH CORPORATION 55 South Market St Suite 1200 San Jose, CA 95113			ALAMEDA CTC 1111 Broadway Suite 800 Oakland, CA 94607		

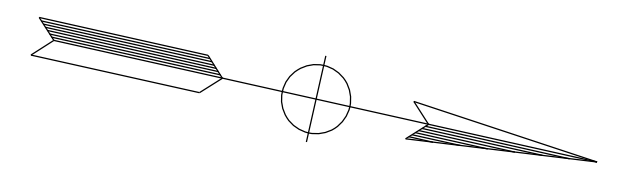

NOTE:
FOR ACCURATE RIGHT OF WAY DATA, CONTACT
RIGHT OF WAY ENGINEERING AT THE DISTRICT OFFICE.

CALCULATED-DESIGNED BY	JAMIEY VALDIVIA
CHECKED BY	ERIN MCPHERSON
FUNCTIONAL SUPERVISOR	TIMOTHY J. LEE
CONSULTANT	W.M.H. CORPORATION
DEPARTMENT OF TRANSPORTATION	STATE OF CALIFORNIA
CONTRACT NO.	0420000235
DATE	9-29-21
BY	JV
REVISION	9-29-21

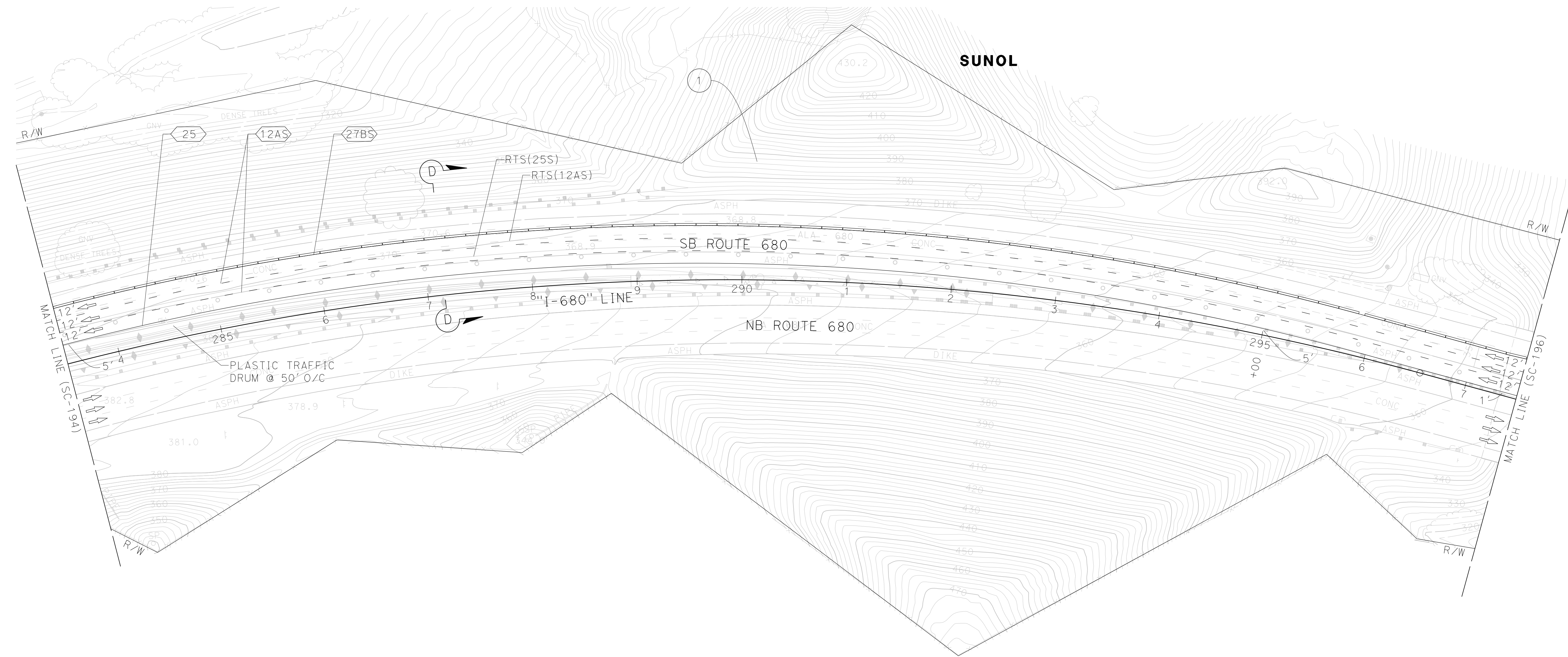

FOR NOTES, ABBREVIATIONS AND
LEGEND, SEE SHEET SC-1 AND SC-186

APPROVED FOR STAGE CONSTRUCTION AND TRAFFIC HANDLING WORK ONLY

STAGE CONSTRUCTION AND TRAFFIC HANDLING PLAN STAGE 4

SCALE: 1" = 50'

SC-195

LAST REVISION DATE PLOTTED => 3/21/2022 09-29-21 TIME PLOTTED => 4:12:34 PM

Dist	COUNTY	ROUTE	POST MILES TOTAL PROJECT	SHEET No.	TOTAL SHEETS
04	Ala, CC	680	R11.0/R21.9, RO.0/RO.9	709	1710
			9-29-21		
REGISTERED CIVIL ENGINEER			DATE		
October 8, 2021			PLANS APPROVAL DATE		
<small>THE STATE OF CALIFORNIA OR ITS OFFICERS OR AGENTS SHALL NOT BE RESPONSIBLE FOR THE ACCURACY OR COMPLETENESS OF SCANNED COPIES OF THIS PLAN SHEET.</small>					
WMH CORPORATION 55 South Market St Suite 1200 San Jose, CA 95113			ALAMEDA CTC 1111 Broadway Suite 800 Oakland, CA 94607		

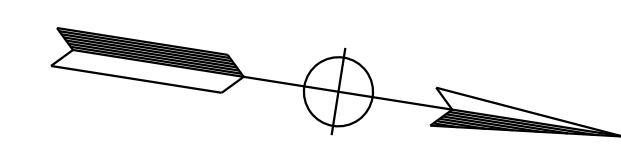

NOTE:
FOR ACCURATE RIGHT OF WAY DATA, CONTACT
RIGHT OF WAY ENGINEERING AT THE DISTRICT OFFICE.

REVISOR	DATE	REVISION
JV	9-29-21	
CALCULATED/DESIGNED BY: JAMEY VALDIVIA		
CHECKED BY: ERIN MCPHERSON		
CONSULTANT SUPERVISOR: TIMOTHY J. LEE		
FUNCTIONAL SUPERVISOR: JAMES VALDIVIA		
DESIGNED BY: ERIN MCPHERSON		
CHECKED BY: ERIN MCPHERSON		

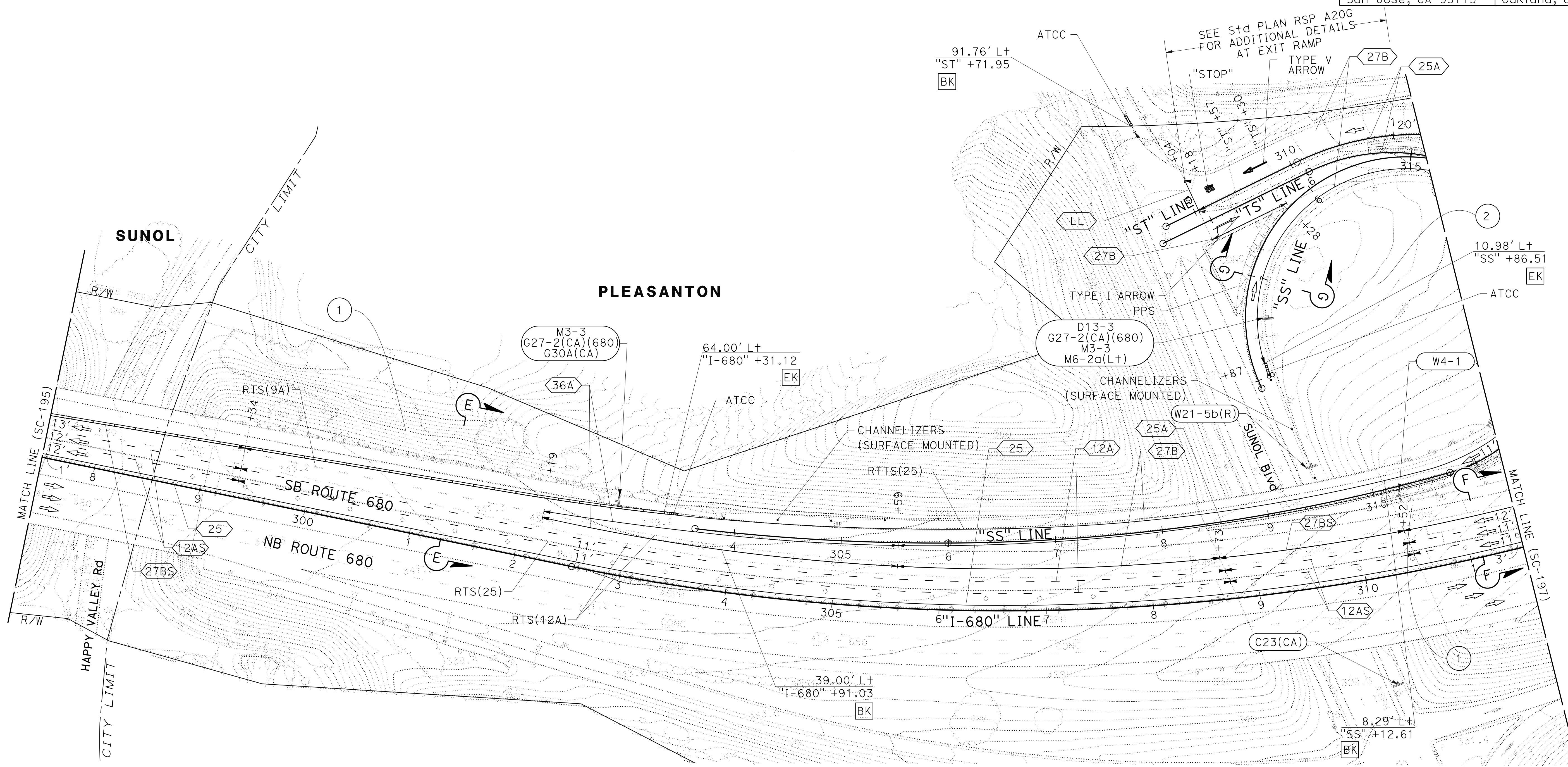

**STAGE CONSTRUCTION
AND TRAFFIC HANDLING PLAN
STAGE 4**

SCALE: 1" = 50'

SC-196

FOR NOTES, ABBREVIATIONS AND
LEGEND, SEE SHEET SC-1 AND SC-186

APPROVED FOR STAGE CONSTRUCTION AND TRAFFIC HANDLING WORK ONLY

LAST REVISION: DATE PLOTTED => 7-MAR-2022 09-29-21 TIME PLOTTED => 11:54

Dist	COUNTY	ROUTE	POST MILES TOTAL PROJECT	SHEET No.	TOTAL SHEETS
04	Ala, CC	680	R11.0/R21.9, RO.0/RO.9	710	1710
			9-29-21		
REGISTERED CIVIL ENGINEER			DATE		
October 8, 2021			PLANS APPROVAL DATE		
THE STATE OF CALIFORNIA OR ITS OFFICERS OR AGENTS SHALL NOT BE RESPONSIBLE FOR THE ACCURACY OR COMPLETENESS OF SCANNED COPIES OF THIS PLAN SHEET.					
WMH CORPORATION 55 South Market St Suite 1200 San Jose, CA 95113			ALAMEDA CTC 1111 Broadway Suite 800 Oakland, CA 94607		

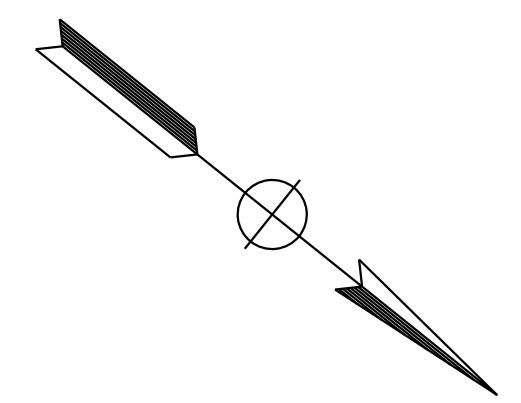

NOTE:
FOR ACCURATE RIGHT OF WAY DATA, CONTACT RIGHT OF WAY ENGINEERING AT THE DISTRICT OFFICE.

REVISOR	DATE	REVISION
JV	9-29-21	
JAMEY VALDIVIA		
ERIN McPHERSON		
CALCULATED/DESIGNED BY	CHECKED BY	
TIMOTHY J. LEE		
CONSULTANT FUNCTIONAL SUPERVISOR		
DEPARTMENT OF TRANSPORTATION		
STATE OF CALIFORNIA		

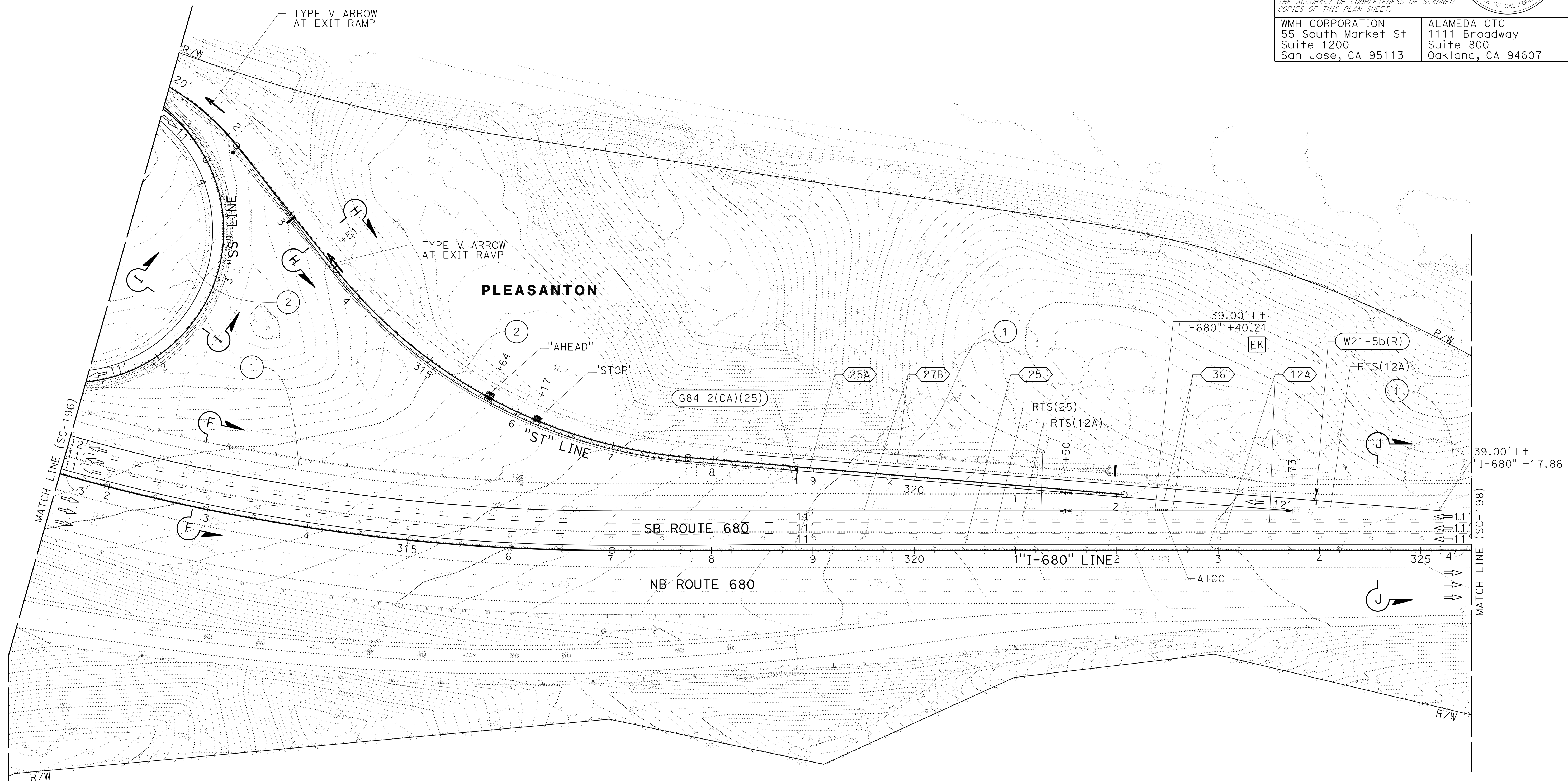

FOR NOTES, ABBREVIATIONS AND LEGEND, SEE SHEET SC-1 AND SC-186

STAGE CONSTRUCTION AND TRAFFIC HANDLING PLAN STAGE 4

SCALE: 1" = 50'

APPROVED FOR STAGE CONSTRUCTION AND TRAFFIC HANDLING WORK ONLY

SC-197

LAST REVISION: 09-29-21 DATE PLOTTED => 7-MAR-2022 TIME PLOTTED => 11:54

NOTE:
FOR ACCURATE RIGHT OF WAY DATA, CONTACT
RIGHT OF WAY ENGINEERING AT THE DISTRICT OFFICE.

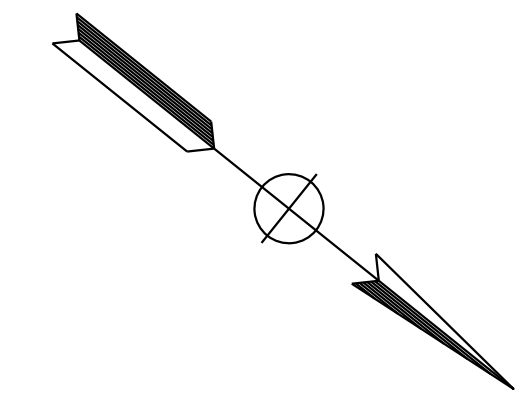

Dist	COUNTY	ROUTE	POST MILES TOTAL PROJECT	SHEET No.	TOTAL SHEETS
04	Ala, CC	680	R11.0/R21.9, R0.0/R0.9	711	1710

<i>Erin D. McPherson</i> REGISTERED CIVIL ENGINEER	9-29-21 DATE
October 8, 2021 PLANS APPROVAL DATE	

ERIN D. McPHERSON No. C91111 Exp. 3-31-24 CIVIL STATE OF CALIFORNIA	WMH CORPORATION 55 South Market St Suite 1200 San Jose, CA 95113	ALAMEDA CTC 1111 Broadway Suite 800 Oakland, CA 94607
--	---	--

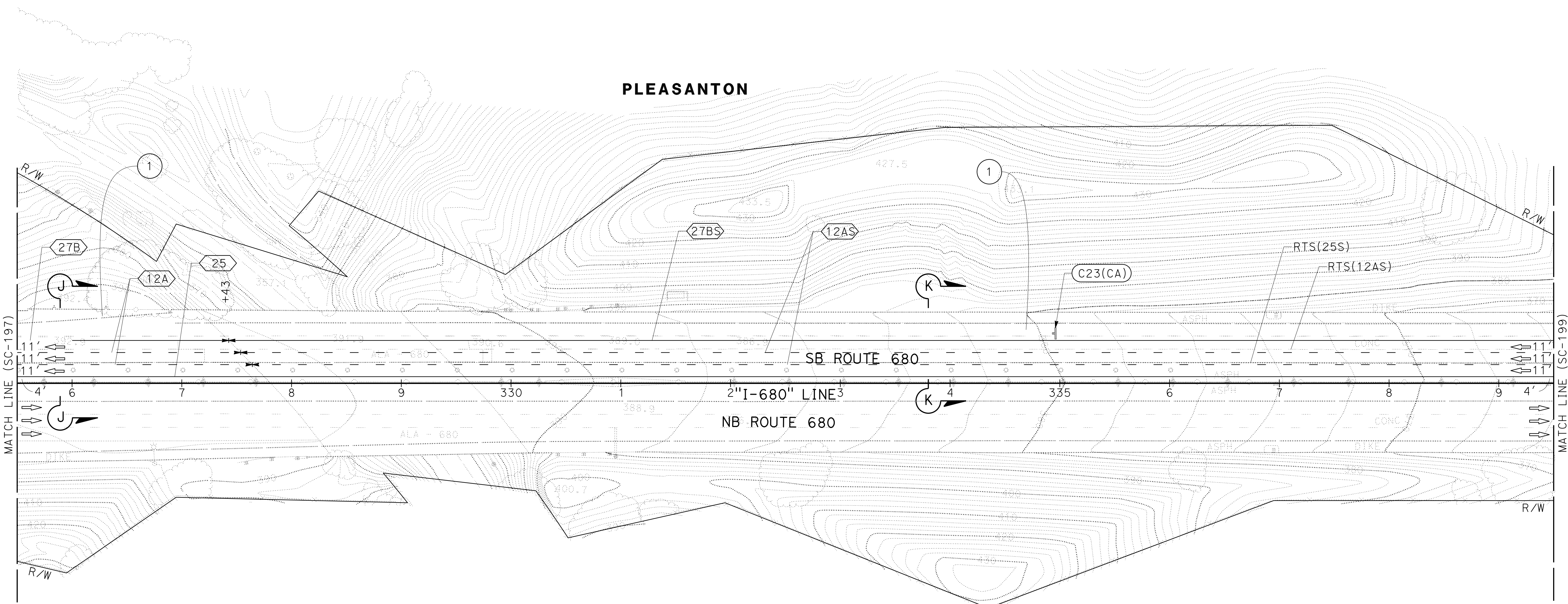

**STAGE CONSTRUCTION
AND TRAFFIC HANDLING PLAN
STAGE 4**

SCALE: 1" = 50'

SC-198

APPROVED FOR STAGE CONSTRUCTION AND TRAFFIC HANDLING WORK ONLY

FOR NOTES, ABBREVIATIONS AND
LEGEND, SEE SHEET SC-1 AND SC-186

O:\00300\DRAWING\FINAL_P58E\0420000235ma198.dgn
 STATE OF CALIFORNIA - DEPARTMENT OF TRANSPORTATION
 Et Caltrans®
 CONSULTANT SUPERVISOR: JIMMY J. LEE
 CHECKED BY: ERIN McPHERSON
 REVISIONS: JV 9-29-21
 DATE REVISION: 9-29-21

NOTE:
FOR ACCURATE RIGHT OF WAY DATA, CONTACT
RIGHT OF WAY ENGINEERING AT THE DISTRICT OFFICE.

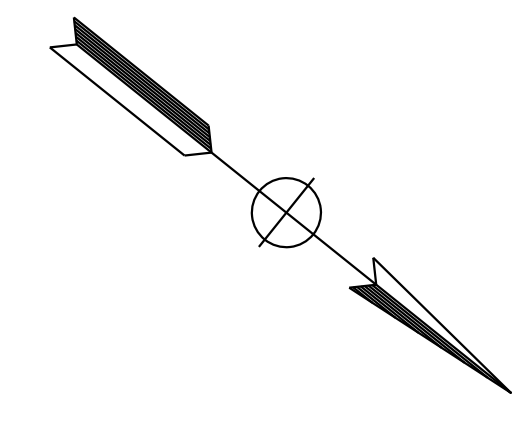

Dist	COUNTY	ROUTE	POST MILES TOTAL PROJECT	SHEET No.	TOTAL SHEETS
04	Ala, CC	680	R11.0/R21.9, R0.0/R0.9	712	1710

REGISTERED CIVIL ENGINEER DATE 9-29-21
 ERIN D. McPHERSON
 No. C91111
 Exp. 3-31-24
 CIVIL
 STATE OF CALIFORNIA

October 8, 2021
 PLANS APPROVAL DATE

THE STATE OF CALIFORNIA OR ITS OFFICERS
 OR AGENTS SHALL NOT BE RESPONSIBLE FOR
 THE ACCURACY OR COMPLETENESS OF SCANNED
 COPIES OF THIS PLAN SHEET.

WMH CORPORATION 55 South Market St Suite 1200 San Jose, CA 95113	ALAMEDA CTC 1111 Broadway Suite 800 Oakland, CA 94607
---	--

REVISOR	DATE	REVISION
JV	9-29-21	
DESIGNED BY	CHECKED BY	CALCULATED/DESIGNED BY
TIMOTHY J. LEE	ERIN McPHERSON	JAMEY VALDIVIA
CONSULTANT	FUNCTIONAL SUPERVISOR	DEPARTMENT OF TRANSPORTATION
ALTA ENGINEERING	TIMOTHY J. LEE	STATE OF CALIFORNIA

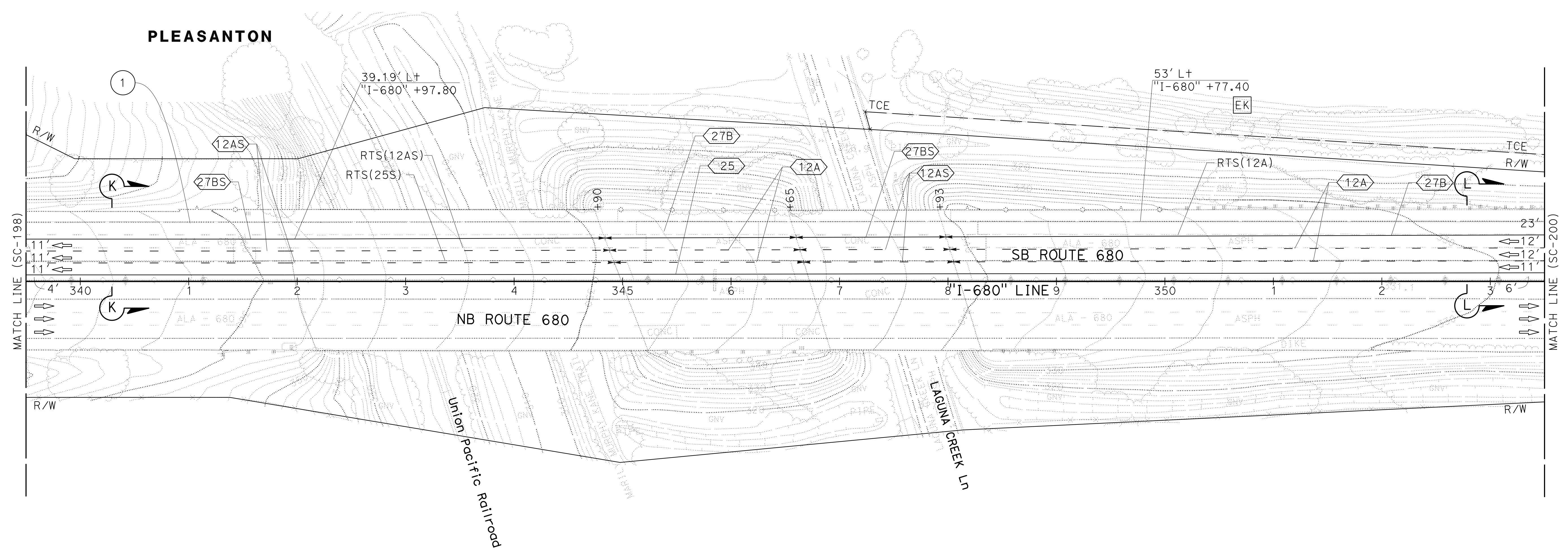

FOR NOTES, ABBREVIATIONS AND
LEGEND, SEE SHEET SC-1 AND SC-186

APPROVED FOR STAGE CONSTRUCTION AND TRAFFIC HANDLING WORK ONLY

**STAGE CONSTRUCTION
AND TRAFFIC HANDLING PLAN
STAGE 4**

SCALE: 1" = 50'

SC-199

LAST REVISION: 09-29-21 11:54
 DATE PLOTTED => 7-MAR-2022
 TIME PLOTTED => 11:54

Dist	COUNTY	ROUTE	POST MILES TOTAL PROJECT	SHEET No.	TOTAL SHEETS
04	Ala, CC	680	R11.0/R21.9, RO.0/RO.9	713	1710
			REGISTERED CIVIL ENGINEER DATE 9-29-21 ERIN D. McPHERSON No. C91111 Exp. 3-31-24 CIVIL STATE OF CALIFORNIA		
			October 8, 2021 PLANS APPROVAL DATE		
WMH CORPORATION 55 South Market St Suite 1200 San Jose, CA 95113			ALAMEDA CTC 1111 Broadway Suite 800 Oakland, CA 94607		

NOTE:
 FOR ACCURATE RIGHT OF WAY DATA, CONTACT
 RIGHT OF WAY ENGINEERING AT THE DISTRICT OFFICE.

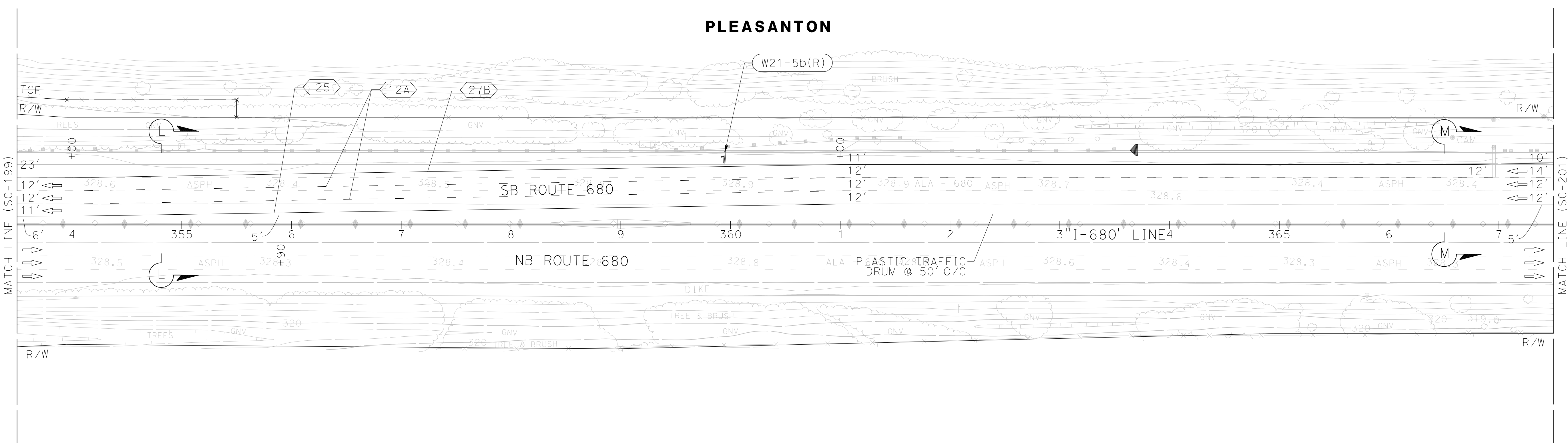
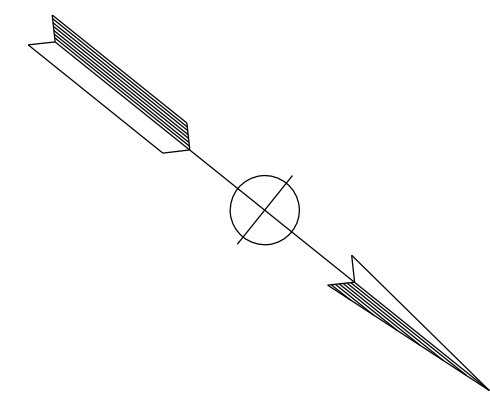

FOR NOTES, ABBREVIATIONS AND
 LEGEND, SEE SHEET SC-1 AND SC-186

APPROVED FOR STAGE CONSTRUCTION AND TRAFFIC HANDLING WORK ONLY

STAGE CONSTRUCTION AND TRAFFIC HANDLING PLAN STAGE 4

SCALE: 1" = 50'

SC-200

CALCULATED-DESIGNED BY	JAMEY VALDIVIA
CHECKED BY	ERIN MCPHERSON
REVISOR	JV
DATE	9-29-21
FUNCTIONAL SUPERVISOR	TIMOTHY J. LEE
STATE OF CALIFORNIA - DEPARTMENT OF TRANSPORTATION	

LAST REVISION DATE PLOTTED => 3/21/2022
 09-29-21 TIME PLOTTED => 4:13:00 PM

STATE OF CALIFORNIA - DEPARTMENT OF TRANSPORTATION
Ernst & Young
JAMEY VALDIVIA
ERIN McPHERSON
TIMOTHY J. LEE

NOTE:
FOR ACCURATE RIGHT OF WAY DATA, CONTACT
RIGHT OF WAY ENGINEERING AT THE DISTRICT OFFICE.

Dist	COUNTY	ROUTE	POST MILES TOTAL PROJECT	SHEET No.	TOTAL SHEETS
04	Ala, CC	680	R11.0/R21.9, R0.0/R0.9	714	1710
			REGISTERED CIVIL ENGINEER	9-29-21	DATE
			October 8, 2021	PLANS APPROVAL DATE	
			THE STATE OF CALIFORNIA OR ITS OFFICERS OR AGENTS SHALL NOT BE RESPONSIBLE FOR THE ACCURACY OR COMPLETENESS OF SCANNED COPIES OF THIS PLAN SHEET.		
WMH CORPORATION 55 South Market St Suite 1200 San Jose, CA 95113		ALAMEDA CTC 1111 Broadway Suite 800 Oakland, CA 94607			

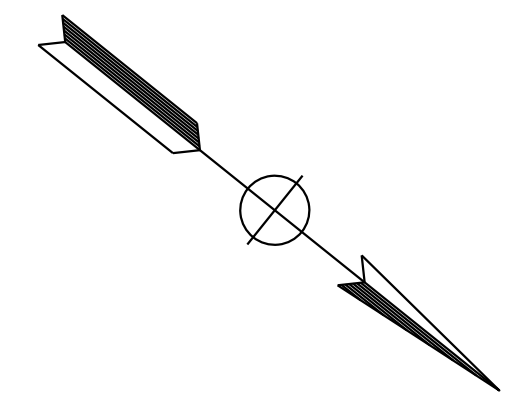

PLEASANTON

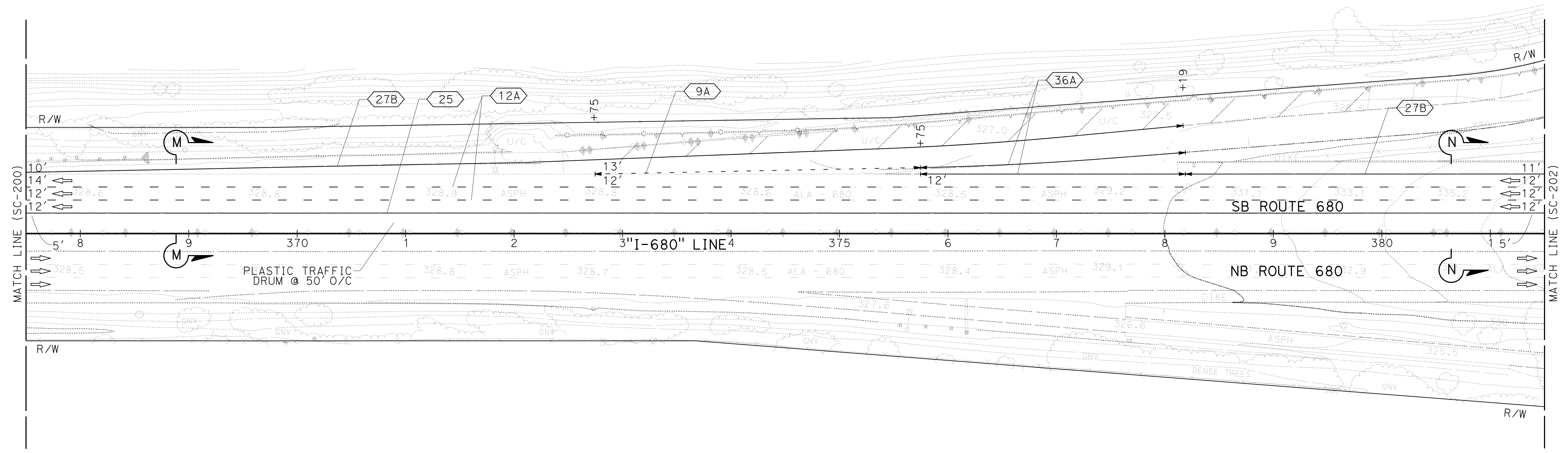

FOR NOTES, ABBREVIATIONS AND
LEGEND, SEE SHEET SC-1 AND SC-186

APPROVED FOR STAGE CONSTRUCTION AND TRAFFIC HANDLING WORK ONLY

STAGE CONSTRUCTION
AND TRAFFIC HANDLING PLAN
STAGE 4

SCALE: 1" = 50'

SC-201

Dist	COUNTY	ROUTE	POST MILES TOTAL PROJECT	SHEET No.	TOTAL SHEETS
04	Ala, CC	680	R11.0/R21.9, RO.0/RO.9	715	1710
			9-29-21		
REGISTERED CIVIL ENGINEER			DATE		
October 8, 2021			PLANS APPROVAL DATE		
<small>THE STATE OF CALIFORNIA OR ITS OFFICERS OR AGENTS SHALL NOT BE RESPONSIBLE FOR THE ACCURACY OR COMPLETENESS OF SCANNED COPIES OF THIS PLAN SHEET.</small>					
WMH CORPORATION 55 South Market St Suite 1200 San Jose, CA 95113			ALAMEDA CTC 1111 Broadway Suite 800 Oakland, CA 94607		

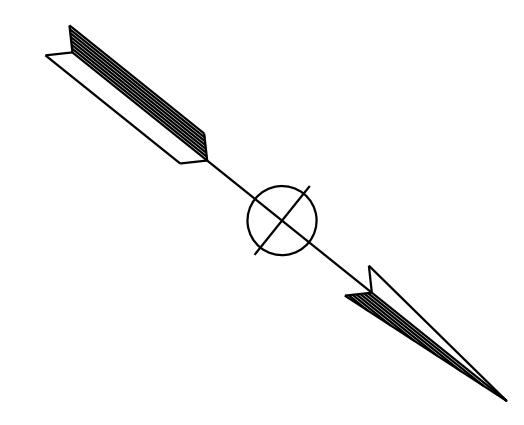

NOTE:
FOR ACCURATE RIGHT OF WAY DATA, CONTACT
RIGHT OF WAY ENGINEERING AT THE DISTRICT OFFICE.

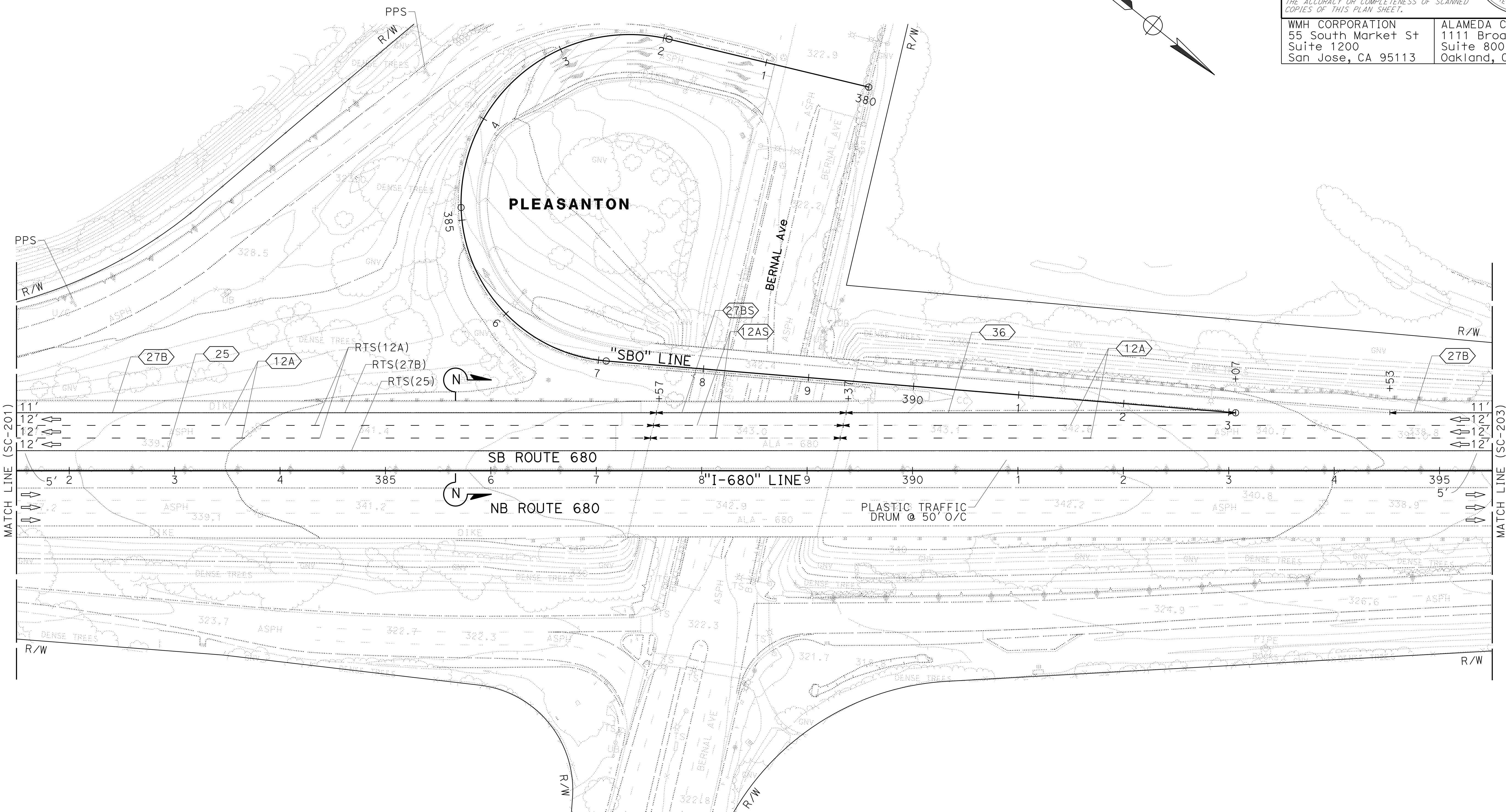

DESIGNED BY	JAMEY VALDIVIA						
CHECKED BY	ERIN MCPHERSON						
REVISIONS	<table border="1"> <tr> <th>NO.</th> <th>DATE</th> <th>REVISION</th> </tr> <tr> <td>1</td> <td>9-29-21</td> <td>JV</td> </tr> </table>	NO.	DATE	REVISION	1	9-29-21	JV
NO.	DATE	REVISION					
1	9-29-21	JV					
FUNCTIONAL SUPERVISOR	TIMOTHY J. LEE						
CONSULTANT	DEPARTMENT OF TRANSPORTATION						
STATE OF CALIFORNIA	DEPARTMENT OF TRANSPORTATION						

FOR NOTES, ABBREVIATIONS AND
LEGEND, SEE SHEET SC-1 AND SC-186

APPROVED FOR STAGE CONSTRUCTION AND TRAFFIC HANDLING WORK ONLY

STAGE CONSTRUCTION AND TRAFFIC HANDLING PLAN STAGE 4

SCALE: 1" = 50'

SC-202

X:\680_SB_EXPRESS\000_CAD\Submit\11\11\CADD_sub\11\11\0420000235ma203.dgn
 STATE OF CALIFORNIA - DEPARTMENT OF TRANSPORTATION
 CONSULTANT FUNCTIONAL SUPERVISOR
 JAMEY VALDIVIA
 ERIN MCPHERSON
 TIMOTHY J. LEE
 Calculated/Designed by
 Checked by
 Revised by
 Date Revised
 JV
 9-29-21

NOTE:
 FOR ACCURATE RIGHT OF WAY DATA, CONTACT
 RIGHT OF WAY ENGINEERING AT THE DISTRICT OFFICE.

Dist	COUNTY	ROUTE	POST MILES TOTAL PROJECT	SHEET No.	TOTAL SHEETS
04	Ala, CC	680	R11.0/R21.9, R0.0/R0.9	716	1710

9-29-21
 REGISTERED CIVIL ENGINEER DATE
 October 8, 2021
 PLANS APPROVAL DATE

ERIN D. MCPHERSON
 No. C91111
 Exp. 3-31-24
 CIVIL
 STATE OF CALIFORNIA

THE STATE OF CALIFORNIA OR ITS OFFICERS
 OR AGENTS SHALL NOT BE RESPONSIBLE FOR
 THE ACCURACY OR COMPLETENESS OF SCANNED
 COPIES OF THIS PLAN SHEET.

WMH CORPORATION 55 South Market St Suite 1200 San Jose, CA 95113	ALAMEDA CTC 1111 Broadway Suite 800 Oakland, CA 94607
---	--

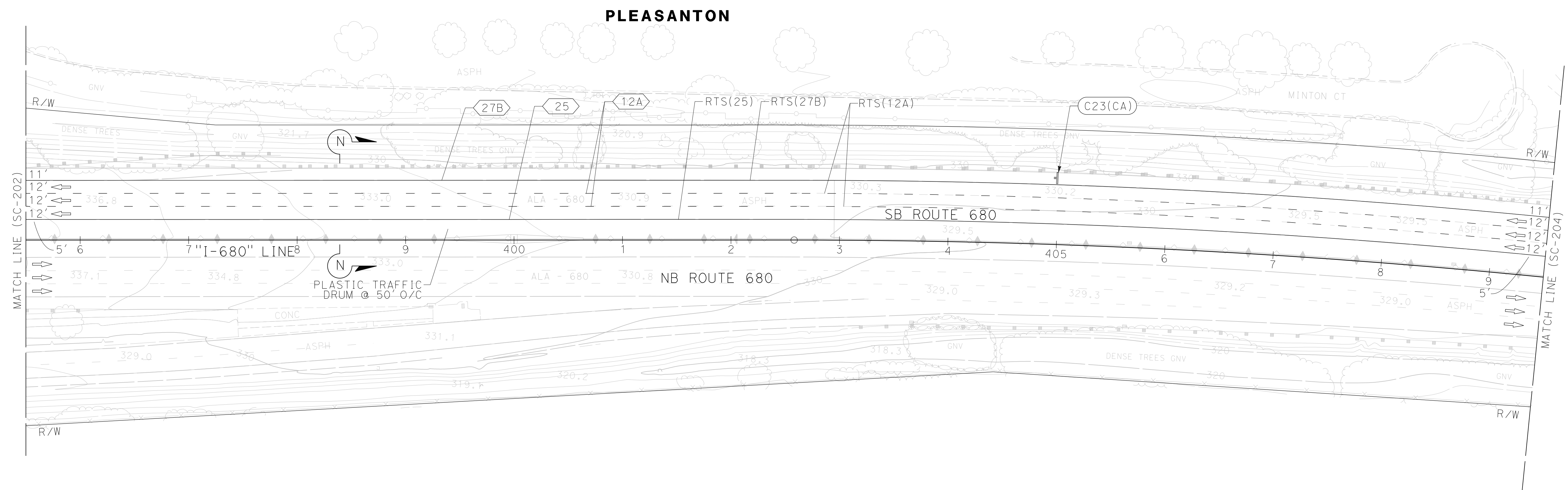
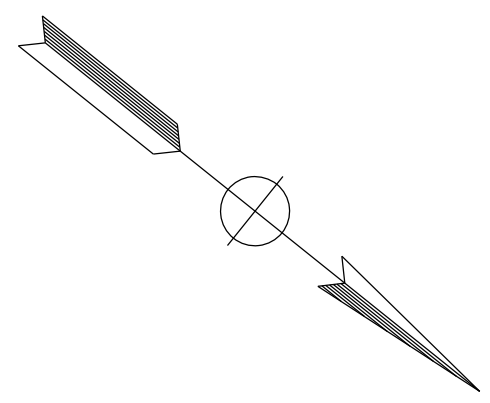

FOR NOTES, ABBREVIATIONS AND
 LEGEND, SEE SHEET SC-1 AND SC-186

APPROVED FOR STAGE CONSTRUCTION AND TRAFFIC HANDLING WORK ONLY

**STAGE CONSTRUCTION
 AND TRAFFIC HANDLING PLAN
 STAGE 4**

SCALE: 1" = 50'

SC-203

LAST REVISION DATE PLOTTED => 3/21/2022
 09-29-21 TIME PLOTTED => 4:13:14 PM

Dist	COUNTY	ROUTE	POST MILES TOTAL PROJECT	SHEET No.	TOTAL SHEETS
04	Ala, CC	680	R11.0/R21.9, R0.0/R0.9	717	1710
			REGISTERED CIVIL ENGINEER	DATE	
			ERIN D. McPHERSON	9-29-21	
			PLANS APPROVAL DATE		
			October 8, 2021		
<small>THE STATE OF CALIFORNIA OR ITS OFFICERS OR AGENTS SHALL NOT BE RESPONSIBLE FOR THE ACCURACY OR COMPLETENESS OF SCANNED COPIES OF THIS PLAN SHEET.</small>					
WMH CORPORATION 55 South Market St Suite 1200 San Jose, CA 95113			ALAMEDA CTC 1111 Broadway Suite 800 Oakland, CA 94607		

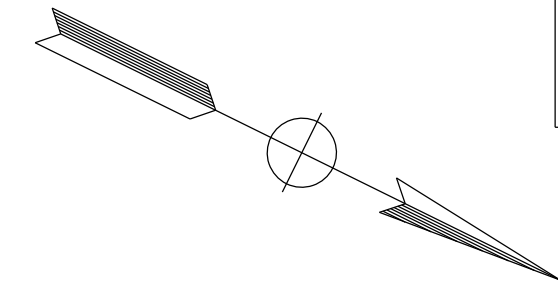

NOTE:
 FOR ACCURATE RIGHT OF WAY DATA, CONTACT
 RIGHT OF WAY ENGINEERING AT THE DISTRICT OFFICE.

STATE OF CALIFORNIA - DEPARTMENT OF TRANSPORTATION	CONSULTANT	FUNCTIONAL SUPERVISOR	CALCULATED-DESIGNED BY	REVISOR	DATE
	JAMEY VALDIVIA	TIMOTHY J. LEE	ERIN McPHERSON	JV	9-29-21
	ERIN McPHERSON				

PLEASANTON

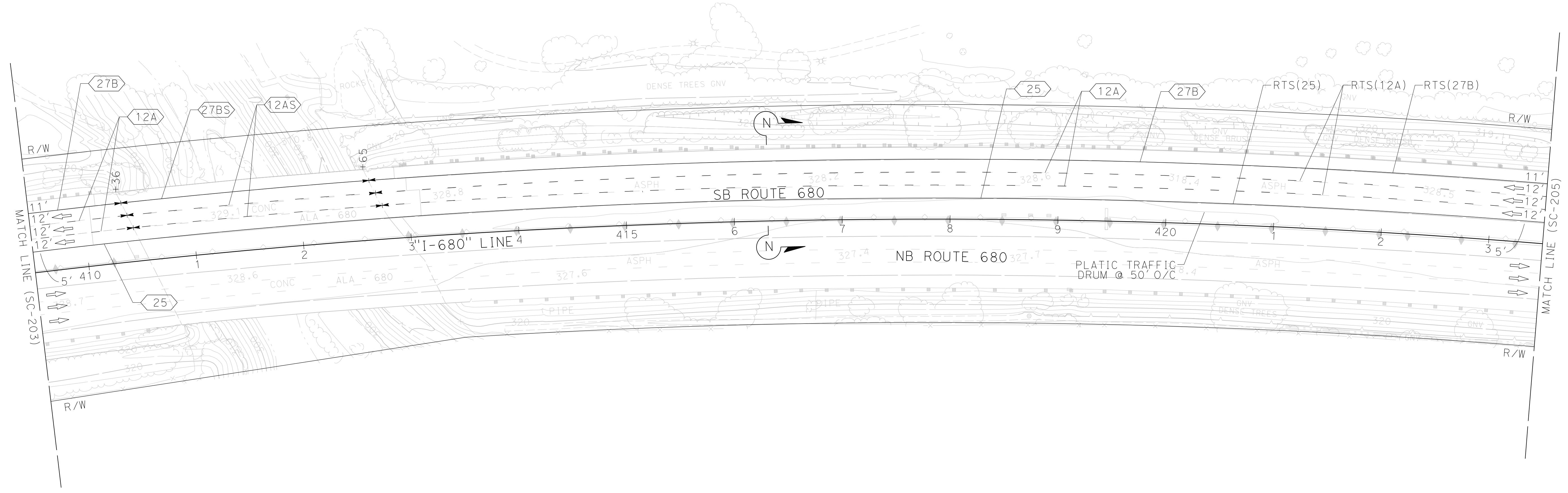

FOR NOTES, ABBREVIATIONS AND
 LEGEND, SEE SHEET SC-1 AND SC-186

**STAGE CONSTRUCTION
 AND TRAFFIC HANDLING PLAN
 STAGE 4**

SCALE: 1" = 50'

SC-204

APPROVED FOR STAGE CONSTRUCTION AND TRAFFIC HANDLING WORK ONLY

LAST REVISION DATE PLOTTED => 3/21/2022 09-29-21 TIME PLOTTED => 4:13:18 PM

X:\680_SB_EXPRESS\000_CAD\Submit\11\11\CADD_submit\11\11\0420000235ma205.dgn
 STATE OF CALIFORNIA - DEPARTMENT OF TRANSPORTATION
 Et Caltrans®
 CONSULTANT FUNCTIONAL SUPERVISOR: TIMOTHY J. LEE
 CALCULATED/DESIGNED BY: JAMEY VALDIVIA
 CHECKED BY: ERIN MCPHERSON
 REVISED BY: J.V.
 DATE REVISED: 9-29-21

NOTE:
 FOR ACCURATE RIGHT OF WAY DATA, CONTACT
 RIGHT OF WAY ENGINEERING AT THE DISTRICT OFFICE.

Dist	COUNTY	ROUTE	POST MILES TOTAL PROJECT	SHEET No.	TOTAL SHEETS
04	Ala, CC	680	R11.0/R21.9, R0.0/R0.9	718	1710

ERIN D. McPHERSON
 REGISTERED CIVIL ENGINEER
 DATE: 9-29-21
 October 8, 2021
 PLANS APPROVAL DATE
 No. C91111
 Exp. 3-31-24
 CIVIL
 STATE OF CALIFORNIA

THE STATE OF CALIFORNIA OR ITS OFFICERS
 OR AGENTS SHALL NOT BE RESPONSIBLE FOR
 THE ACCURACY OR COMPLETENESS OF SCANNED
 COPIES OF THIS PLAN SHEET.

WMH CORPORATION 55 South Market St Suite 1200 San Jose, CA 95113	ALAMEDA CTC 1111 Broadway Suite 800 Oakland, CA 94607
---	--

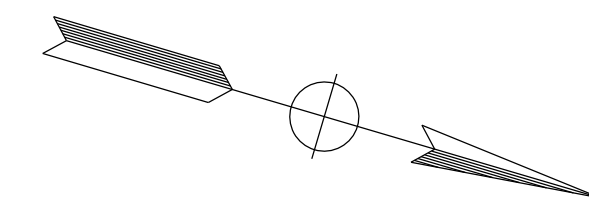

PLEASANTON

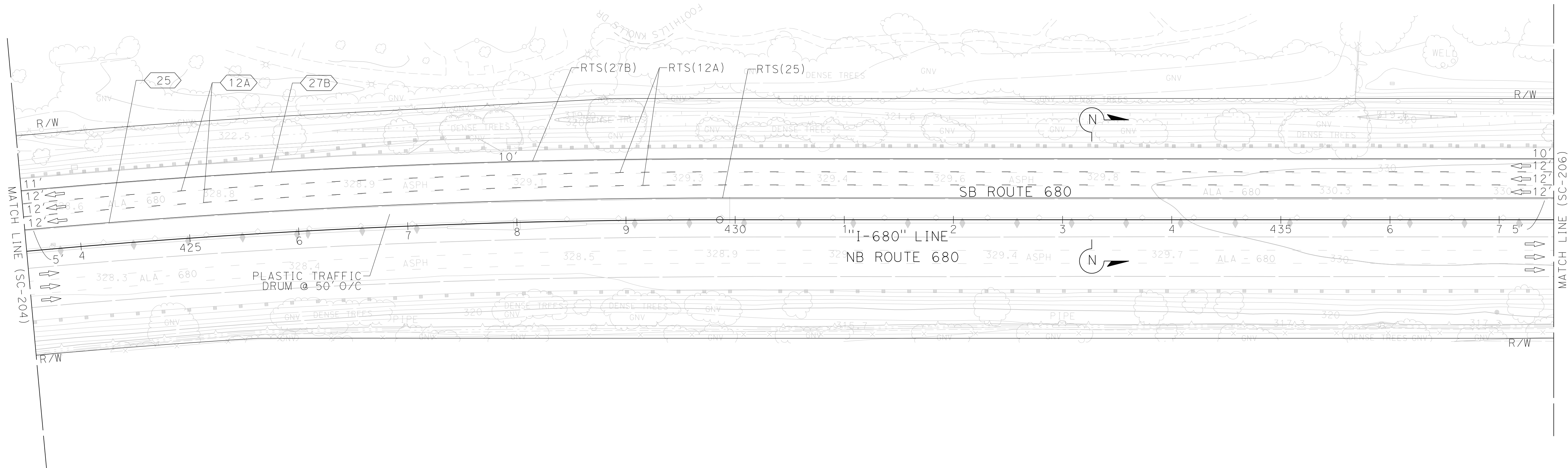

FOR NOTES, ABBREVIATIONS AND
 LEGEND, SEE SHEET SC-1 AND SC-186

APPROVED FOR STAGE CONSTRUCTION AND TRAFFIC HANDLING WORK ONLY

**STAGE CONSTRUCTION
 AND TRAFFIC HANDLING PLAN
 STAGE 4**

SCALE: 1" = 50'

SC-205

LAST REVISION: 09-29-21
 DATE PLOTTED => 3/21/2022
 TIME PLOTTED => 4:13:22 PM

X:\680_SB_EXPRESS\000_CAD\Submittal\0420000235ma206.dgn
 STATE OF CALIFORNIA - DEPARTMENT OF TRANSPORTATION
Caltrans
 CONSULTANT FUNCTIONAL SUPERVISOR: TIMOTHY J. LEE
 CALCULATED/DESIGNED BY: JAMEY VALDIVIA
 CHECKED BY: ERIN MCPHERSON
 REVISED BY: JV
 DATE REVISED: 9-29-21

NOTE:
 FOR ACCURATE RIGHT OF WAY DATA, CONTACT
 RIGHT OF WAY ENGINEERING AT THE DISTRICT OFFICE.

Dist	COUNTY	ROUTE	POST MILES TOTAL PROJECT	SHEET No.	TOTAL SHEETS
04	Ala, CC	680	R11.0/R21.9, R0.0/R0.9	719	1710

ERIN D. McPHERSON
 REGISTERED CIVIL ENGINEER
 No. C91111
 Exp. 3-31-24
 CIVIL
 STATE OF CALIFORNIA

9-29-21
 DATE
 REGISTERED CIVIL ENGINEER

October 8, 2021
 PLANS APPROVAL DATE

THE STATE OF CALIFORNIA OR ITS OFFICERS
 OR AGENTS SHALL NOT BE RESPONSIBLE FOR
 THE ACCURACY OR COMPLETENESS OF SCANNED
 COPIES OF THIS PLAN SHEET.

WMH CORPORATION 55 South Market St Suite 1200 San Jose, CA 95113	ALAMEDA CTC 1111 Broadway Suite 800 Oakland, CA 94607
---	--

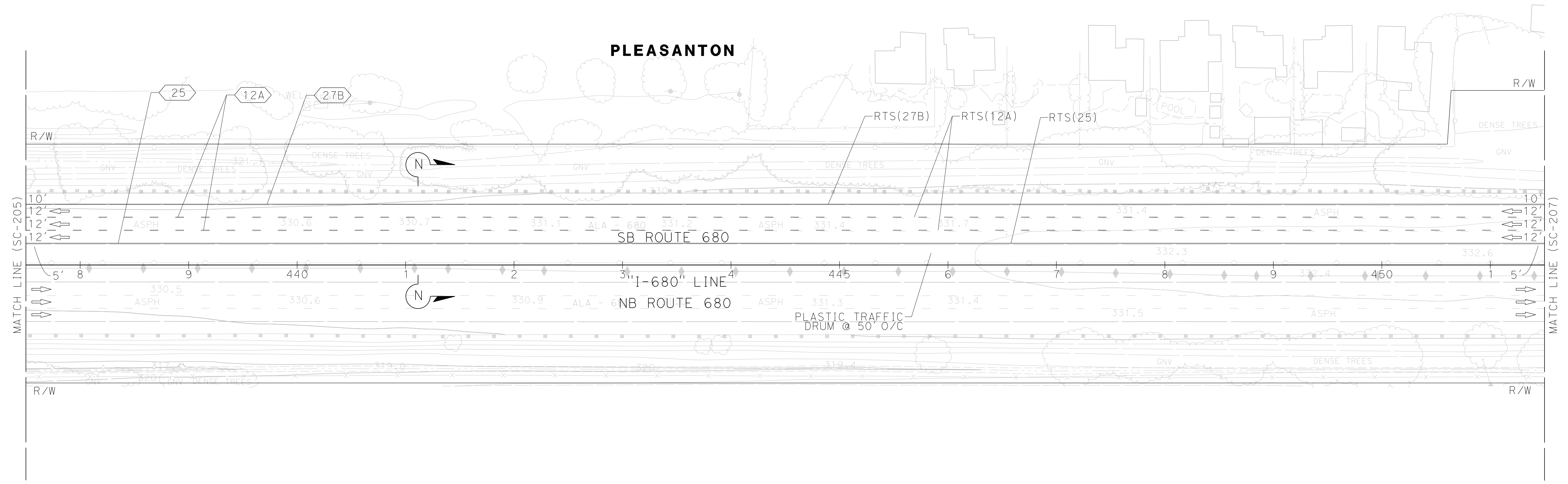
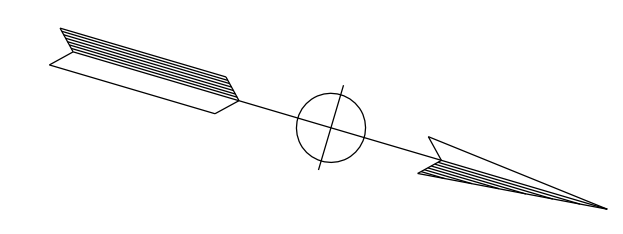

FOR NOTES, ABBREVIATIONS AND
 LEGEND, SEE SHEET SC-1 AND SC-186

APPROVED FOR STAGE CONSTRUCTION AND TRAFFIC HANDLING WORK ONLY

**STAGE CONSTRUCTION
 AND TRAFFIC HANDLING PLAN
 STAGE 4**

SCALE: 1" = 50'

SC-206

LAST REVISION DATE PLOTTED => 3/21/2022
 09-29-21 TIME PLOTTED => 4:13:21 PM

Dist	COUNTY	ROUTE	POST MILES TOTAL PROJECT	SHEET No.	TOTAL SHEETS
04	Ala, CC	680	R11.0/R21.9, RO.0/RO.9	720	1710
			9-29-21		
REGISTERED CIVIL ENGINEER			DATE		
October 8, 2021			PLANS APPROVAL DATE		
<small>THE STATE OF CALIFORNIA OR ITS OFFICERS OR AGENTS SHALL NOT BE RESPONSIBLE FOR THE ACCURACY OR COMPLETENESS OF SCANNED COPIES OF THIS PLAN SHEET.</small>					
WMH CORPORATION 55 South Market St Suite 1200 San Jose, CA 95113			ALAMEDA CTC 1111 Broadway Suite 800 Oakland, CA 94607		

NOTE:
FOR ACCURATE RIGHT OF WAY DATA, CONTACT
RIGHT OF WAY ENGINEERING AT THE DISTRICT OFFICE.

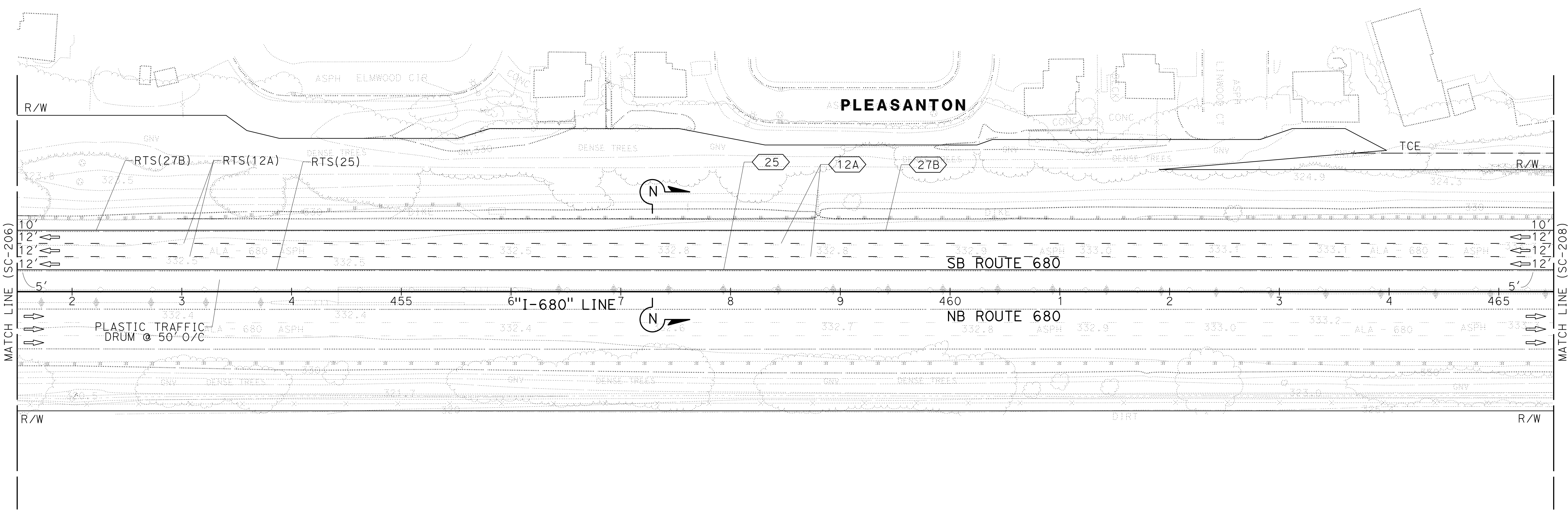
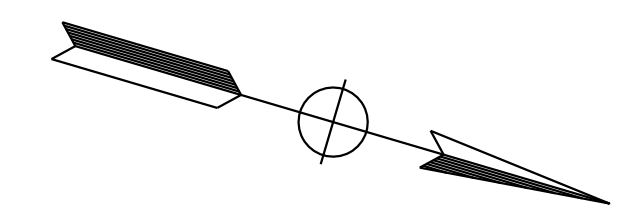

O:\00300\DRAWING\FINAL_P58E\0420000235ma207.dgn
 STATE OF CALIFORNIA - DEPARTMENT OF TRANSPORTATION
 Et Caltrans®
 CONSULTANT - FUNCTIONAL SUPERVISOR
 JIMMY VALDIVIA
 ERIN MCPHERSON
 CHECKED BY
 TIMOTHY J. LEE
 REVISIONS
 REVISED BY
 DATE REVISED
 JV
 9-29-21

FOR NOTES, ABBREVIATIONS AND
LEGEND, SEE SHEET SC-1 AND SC-186

APPROVED FOR STAGE CONSTRUCTION AND TRAFFIC HANDLING WORK ONLY

STAGE CONSTRUCTION AND TRAFFIC HANDLING PLAN STAGE 4

SCALE: 1" = 50'

SC-207

LAST REVISION DATE PLOTTED => 7-MAR-2022 TIME PLOTTED => 11:55
 09-29-21

X:\680_SB_EXPRESS\000_CAD\Submittal\0420000235ma208.dgn
 STATE OF CALIFORNIA - DEPARTMENT OF TRANSPORTATION
 CONSULTANT FUNCTIONAL SUPERVISOR
 JAMEY VALDIVIA
 ERIN MCPHERSON
 TIMOTHY J. LEE
 Calculated-Designed By
 Checked By
 Revised By
 Date Revised
 JV
 9-29-21

NOTE:
 FOR ACCURATE RIGHT OF WAY DATA, CONTACT
 RIGHT OF WAY ENGINEERING AT THE DISTRICT OFFICE.

Dist	COUNTY	ROUTE	POST MILES TOTAL PROJECT	SHEET No.	TOTAL SHEETS
04	Ala, CC	680	R11.0/R21.9, R0.0/R0.9	721	1710

ERIN D. McPHERSON
 REGISTERED CIVIL ENGINEER
 No. C91111
 Exp. 3-31-24
 CIVIL
 STATE OF CALIFORNIA

9-29-21
 DATE
 REGISTERED CIVIL ENGINEER

October 8, 2021
 PLANS APPROVAL DATE

THE STATE OF CALIFORNIA OR ITS OFFICERS
 OR AGENTS SHALL NOT BE RESPONSIBLE FOR
 THE ACCURACY OR COMPLETENESS OF SCANNED
 COPIES OF THIS PLAN SHEET.

WMH CORPORATION 55 South Market St Suite 1200 San Jose, CA 95113	ALAMEDA CTC 1111 Broadway Suite 800 Oakland, CA 94607
---	--

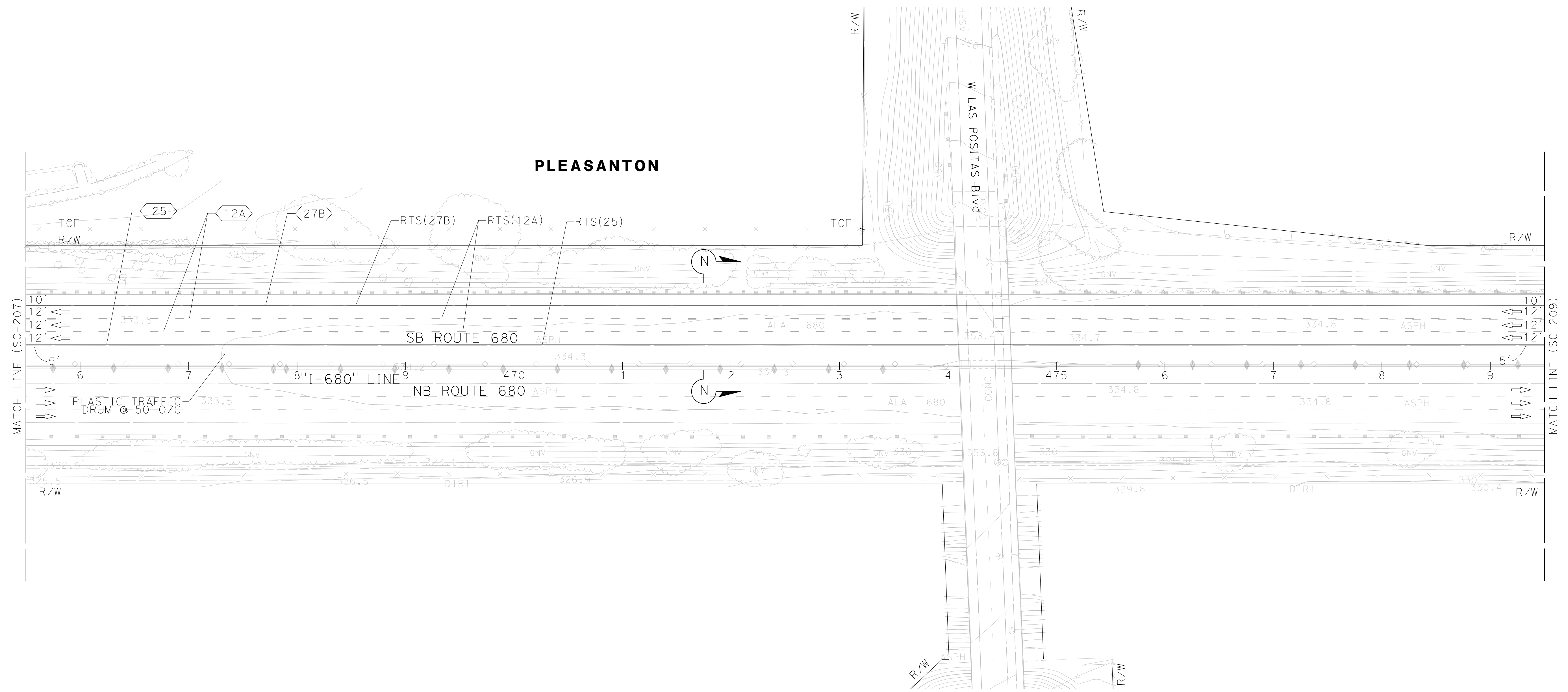
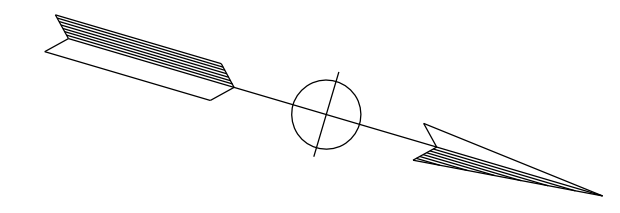

FOR NOTES, ABBREVIATIONS AND
 LEGEND, SEE SHEET SC-1 AND SC-186

APPROVED FOR STAGE CONSTRUCTION AND TRAFFIC HANDLING WORK ONLY

STAGE CONSTRUCTION AND TRAFFIC HANDLING PLAN STAGE 4

SCALE: 1" = 50'

SC-208

LAST REVISION DATE PLOTTED => 3/21/2022
 09-29-21 TIME PLOTTED => 4:13:36 PM

X:\680_SB_EXPRESS\000_CAD\Submittal\0420000235ma209.dgn
 STATE OF CALIFORNIA - DEPARTMENT OF TRANSPORTATION
 CONSULTANT FUNCTIONAL SUPERVISOR
 JAMEY VALDIVIA
 ERIN MCPHERSON
 TIMOTHY J. LEE
 CALCULATED-DESIGNED BY
 CHECKED BY
 REVISED BY
 DATE REVISED
 JV
 9-29-21

NOTE:
 FOR ACCURATE RIGHT OF WAY DATA, CONTACT
 RIGHT OF WAY ENGINEERING AT THE DISTRICT OFFICE.

Dist	COUNTY	ROUTE	POST MILES TOTAL PROJECT	SHEET No.	TOTAL SHEETS
04	Ala, CC	680	R11.0/R21.9, RO.0/RO.9	722	1710

REGISTERED CIVIL ENGINEER *Erin D. McPherson* DATE 9-29-21
 October 8, 2021
 PLANS APPROVAL DATE

ERIN D. MCPHERSON
 No. C91111
 Exp. 3-31-24
 CIVIL
 STATE OF CALIFORNIA

THE STATE OF CALIFORNIA OR ITS OFFICERS OR AGENTS SHALL NOT BE RESPONSIBLE FOR THE ACCURACY OR COMPLETENESS OF SCANNED COPIES OF THIS PLAN SHEET.

WMH CORPORATION 55 South Market St Suite 1200 San Jose, CA 95113	ALAMEDA CTC 1111 Broadway Suite 800 Oakland, CA 94607
---	--

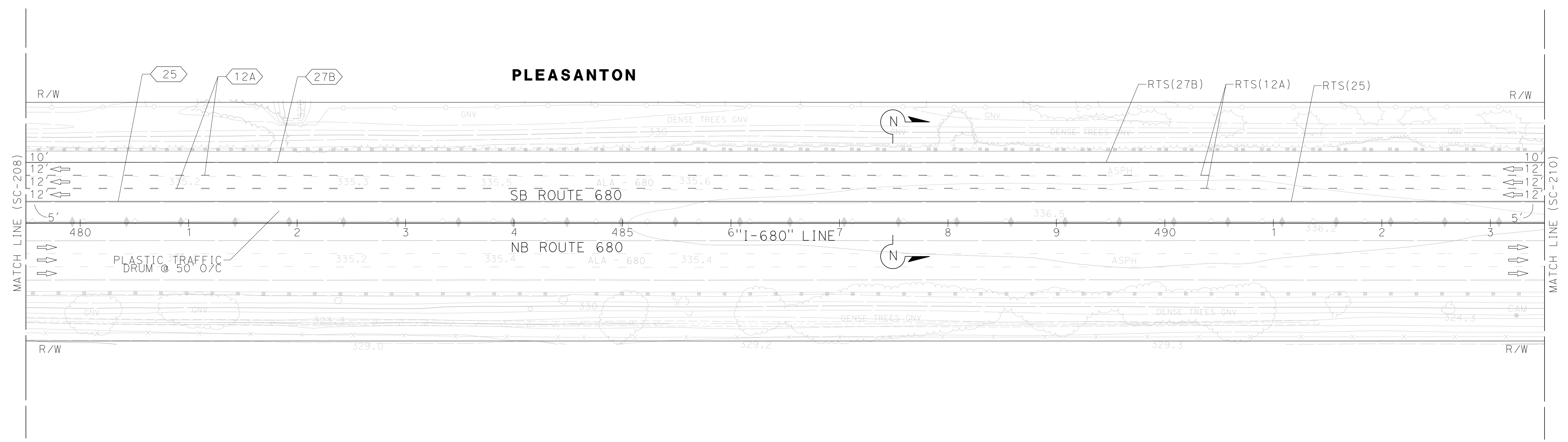
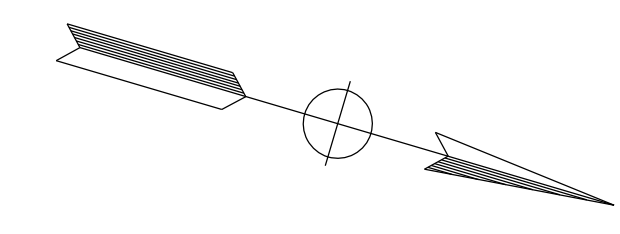

FOR NOTES, ABBREVIATIONS AND
 LEGEND, SEE SHEET SC-1 AND SC-186

APPROVED FOR STAGE CONSTRUCTION AND TRAFFIC HANDLING WORK ONLY

**STAGE CONSTRUCTION
 AND TRAFFIC HANDLING PLAN
 STAGE 4**

SCALE: 1" = 50'

SC-209

LAST REVISION DATE PLOTTED => 3/21/2022
 09-29-21 TIME PLOTTED => 4:13:41 PM

X:\680_SB_EXPRESS\000_CAD\Submittal\11\11\CADD_submittal\0420000235ma210.dgn
 STATE OF CALIFORNIA - DEPARTMENT OF TRANSPORTATION
 Et Caltrans®
 CONSULTANT SUPERVISOR: JIMMY J. LEE
 CHECKED BY: ERIN MCPHERSON
 DESIGNED BY: JAMEY VALDIVIA
 REVISIONS: JV 9-29-21
 DATE REVISION: 9-29-21

NOTE:
 FOR ACCURATE RIGHT OF WAY DATA, CONTACT
 RIGHT OF WAY ENGINEERING AT THE DISTRICT OFFICE.

Dist	COUNTY	ROUTE	POST MILES TOTAL PROJECT	SHEET No.	TOTAL SHEETS
04	Ala, CC	680	R11.0/R21.9, R0.0/R0.9	723	1710

REGISTERED CIVIL ENGINEER: *Erin D. McPherson* DATE: 9-29-21
 PLANS APPROVAL DATE: October 8, 2021
 ERIN D. MCPHERSON No. C91111 Exp. 3-31-24 CIVIL STATE OF CALIFORNIA
 THE STATE OF CALIFORNIA OR ITS OFFICERS OR AGENTS SHALL NOT BE RESPONSIBLE FOR THE ACCURACY OR COMPLETENESS OF SCANNED COPIES OF THIS PLAN SHEET.
 WMH CORPORATION 55 South Market St Suite 1200 San Jose, CA 95113
 ALAMEDA CTC 1111 Broadway Suite 800 Oakland, CA 94607

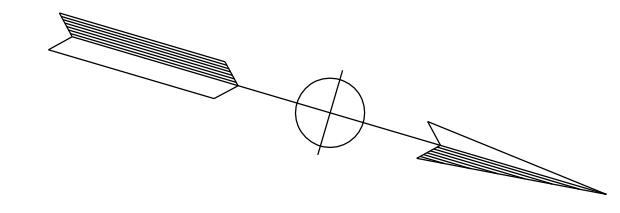

PLEASANTON

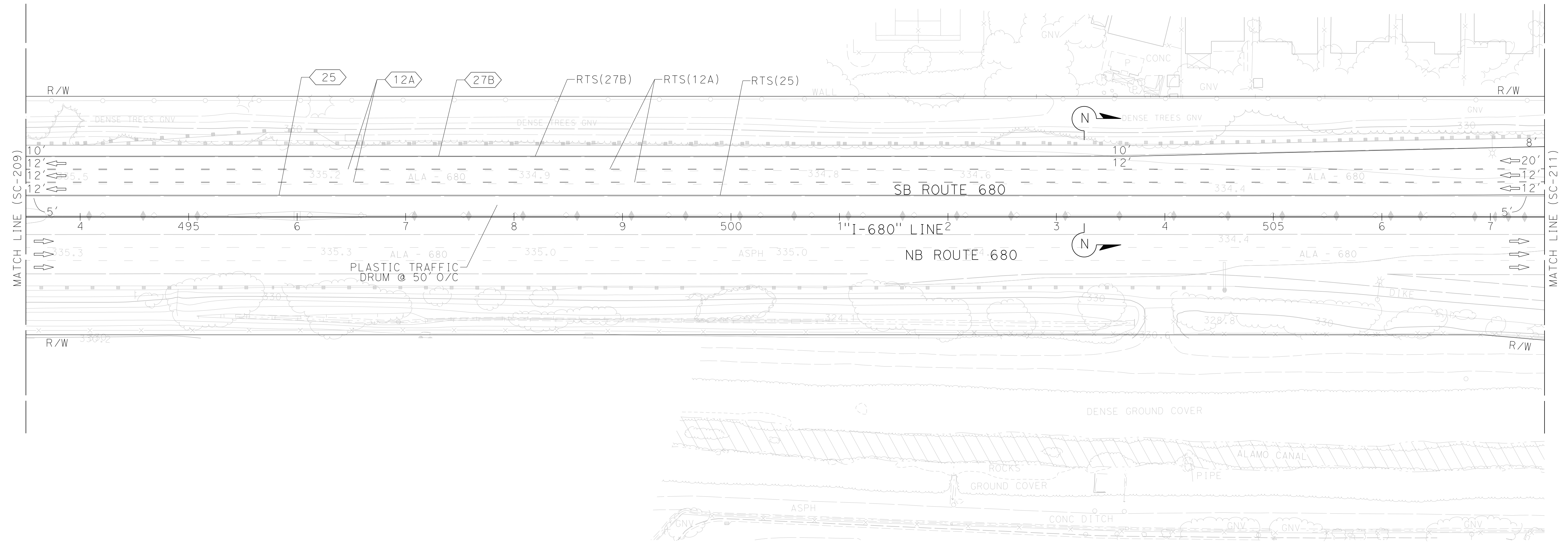

FOR NOTES, ABBREVIATIONS AND LEGEND, SEE SHEET SC-1 AND SC-186

APPROVED FOR STAGE CONSTRUCTION AND TRAFFIC HANDLING WORK ONLY

**STAGE CONSTRUCTION AND TRAFFIC HANDLING PLAN
 STAGE 4**

SCALE: 1" = 50'

SC-210

LAST REVISION: 09-29-21 DATE PLOTTED => 3/21/2022 TIME PLOTTED => 4:13:45 PM

Dist	COUNTY	ROUTE	POST MILES TOTAL PROJECT	SHEET No.	TOTAL SHEETS
04	Ala, CC	680	R11.0/R21.9, RO.0/RO.9	724	1710
			9-29-21		
REGISTERED CIVIL ENGINEER			DATE		
October 8, 2021			PLANS APPROVAL DATE		
WMH CORPORATION 55 South Market St Suite 1200 San Jose, CA 95113			ALAMEDA CTC 1111 Broadway Suite 800 Oakland, CA 94607		

NOTE:
FOR ACCURATE RIGHT OF WAY DATA, CONTACT
RIGHT OF WAY ENGINEERING AT THE DISTRICT OFFICE.

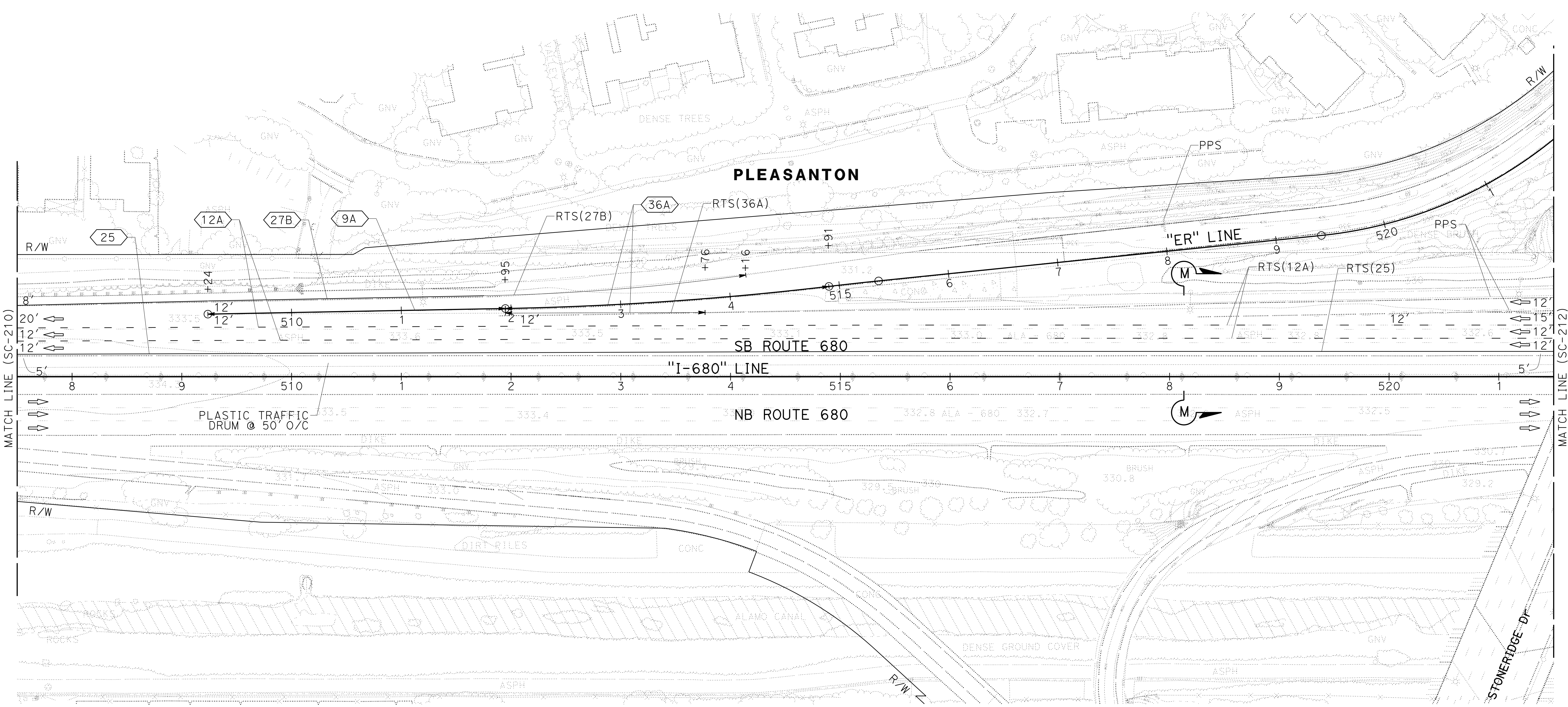
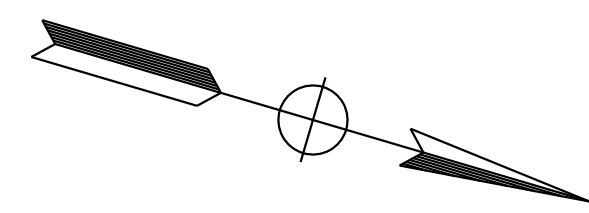

**STAGE CONSTRUCTION
AND TRAFFIC HANDLING PLAN
STAGE 4**

SCALE: 1" = 50'

SC-211

FOR NOTES, ABBREVIATIONS AND
LEGEND, SEE SHEET SC-1 AND SC-186

APPROVED FOR STAGE CONSTRUCTION AND TRAFFIC HANDLING WORK ONLY

STATE OF CALIFORNIA - DEPARTMENT OF TRANSPORTATION	CALCULATED-DESIGNED BY	REVISOR	DATE
Ervin McPherson	JAMIEY VALDIVIA	JV	9-29-21
Ervin McPherson	ERIN MCPHERSON		
TIMOTHY J. LEE			

Dist	COUNTY	ROUTE	POST MILES TOTAL PROJECT	SHEET No.	TOTAL SHEETS
04	Ala, CC	680	R11.0/R21.9, RO.0/RO.9	725	1710
			9-29-21	DATE	
REGISTERED CIVIL ENGINEER			DATE		
October 8, 2021			PLANS APPROVAL DATE		
THE STATE OF CALIFORNIA OR ITS OFFICERS OR AGENTS SHALL NOT BE RESPONSIBLE FOR THE ACCURACY OR COMPLETENESS OF SCANNED COPIES OF THIS PLAN SHEET.					
WMH CORPORATION 55 South Market St Suite 1200 San Jose, CA 95113			ALAMEDA CTC 1111 Broadway Suite 800 Oakland, CA 94607		



NOTE:
FOR ACCURATE RIGHT OF WAY DATA, CONTACT
RIGHT OF WAY ENGINEERING AT THE DISTRICT OFFICE.

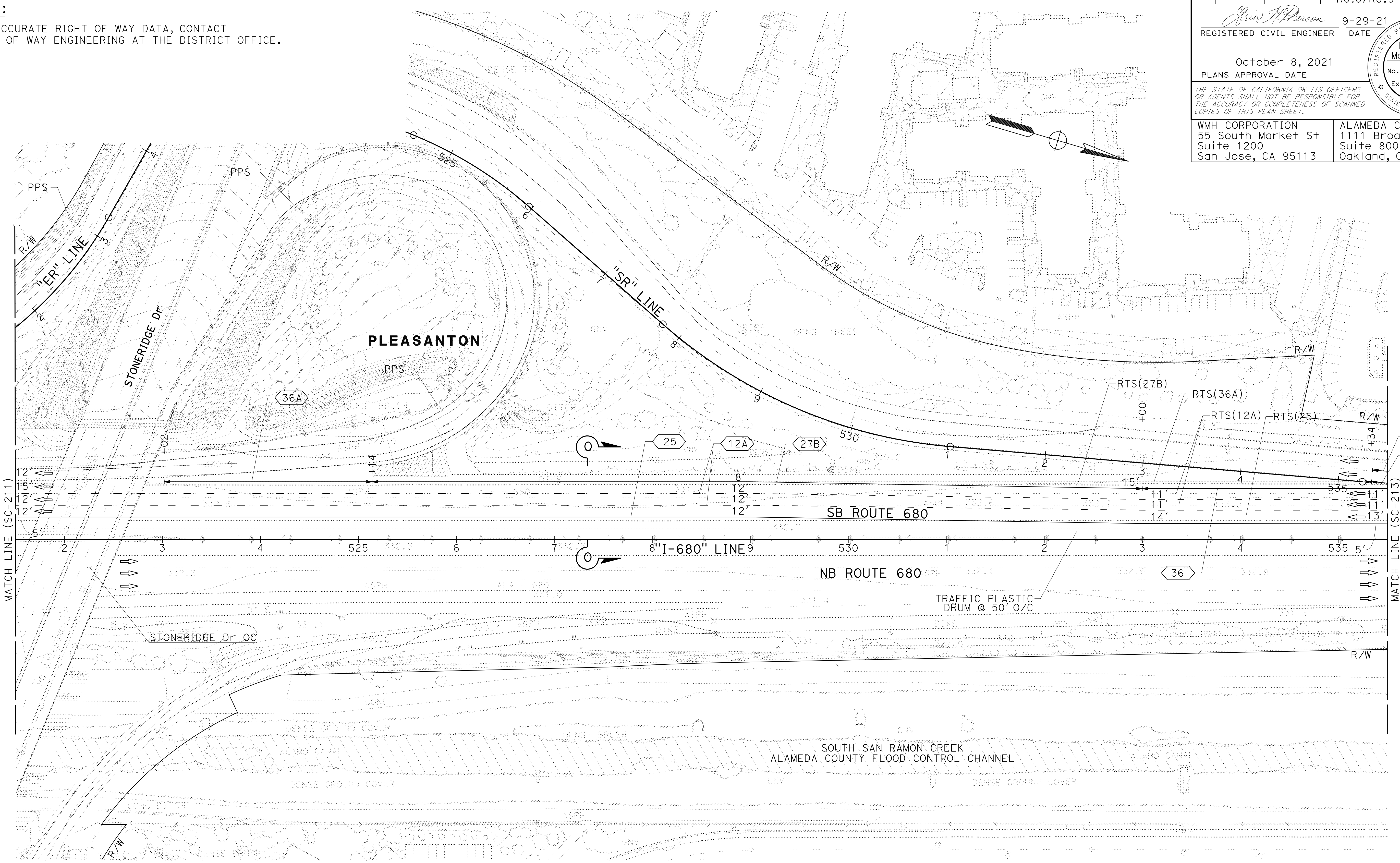

**STAGE CONSTRUCTION
AND TRAFFIC HANDLING PLAN
STAGE 4**

SCALE: 1" = 50'

SC-212

FOR NOTES, ABBREVIATIONS AND
LEGEND, SEE SHEET SC-1 AND SC-186

APPROVED FOR STAGE CONSTRUCTION AND TRAFFIC HANDLING WORK ONLY

STATE OF CALIFORNIA - DEPARTMENT OF TRANSPORTATION	CONSULTANT	FUNCTIONAL SUPERVISOR	CALCULATED-DESIGNED BY	REVISOR	DATE
Erwin	TIMOTHY J. LEE	JAMIEY VALDIVIA	ERIN MCPHERSON	JV	9-29-21

0:\00300\DRAWING\FINAL_P\58E\0420000235m0213.dgn
STATE OF CALIFORNIA - DEPARTMENT OF TRANSPORTATION
Et Caltrans
CONSULTANT: FUNCTIONAL SUPERVISOR: TIMOTHY J. LEE
CALCULATED/DESIGNED BY: JAMEY VALDIVIA
CHECKED BY: ERIN McPHERSON
REVISED BY: JAV
DATE REVISED: 9-29-21

NOTE:
FOR ACCURATE RIGHT OF WAY DATA, CONTACT
RIGHT OF WAY ENGINEERING AT THE DISTRICT OFFICE.

Dist	COUNTY	ROUTE	POST MILES TOTAL PROJECT	SHEET No.	TOTAL SHEETS
04	Ala, CC	680	R11.0/R21.9, R0.0/R0.9	726	1710
REGISTERED CIVIL ENGINEER			DATE		
October 8, 2021			PLANS APPROVAL DATE		
THE STATE OF CALIFORNIA OR ITS OFFICERS OR AGENTS SHALL NOT BE RESPONSIBLE FOR THE ACCURACY OR COMPLETENESS OF SCANNED COPIES OF THIS PLAN SHEET.					
WMH CORPORATION 55 South Market St Suite 1200 San Jose, CA 95113			ALAMEDA CTC 1111 Broadway Suite 800 Oakland, CA 94607		

REGISTERED PROFESSIONAL ENGINEER
ERIN D. McPHERSON
No. C91111
Exp. 3-31-24
CIVIL
STATE OF CALIFORNIA

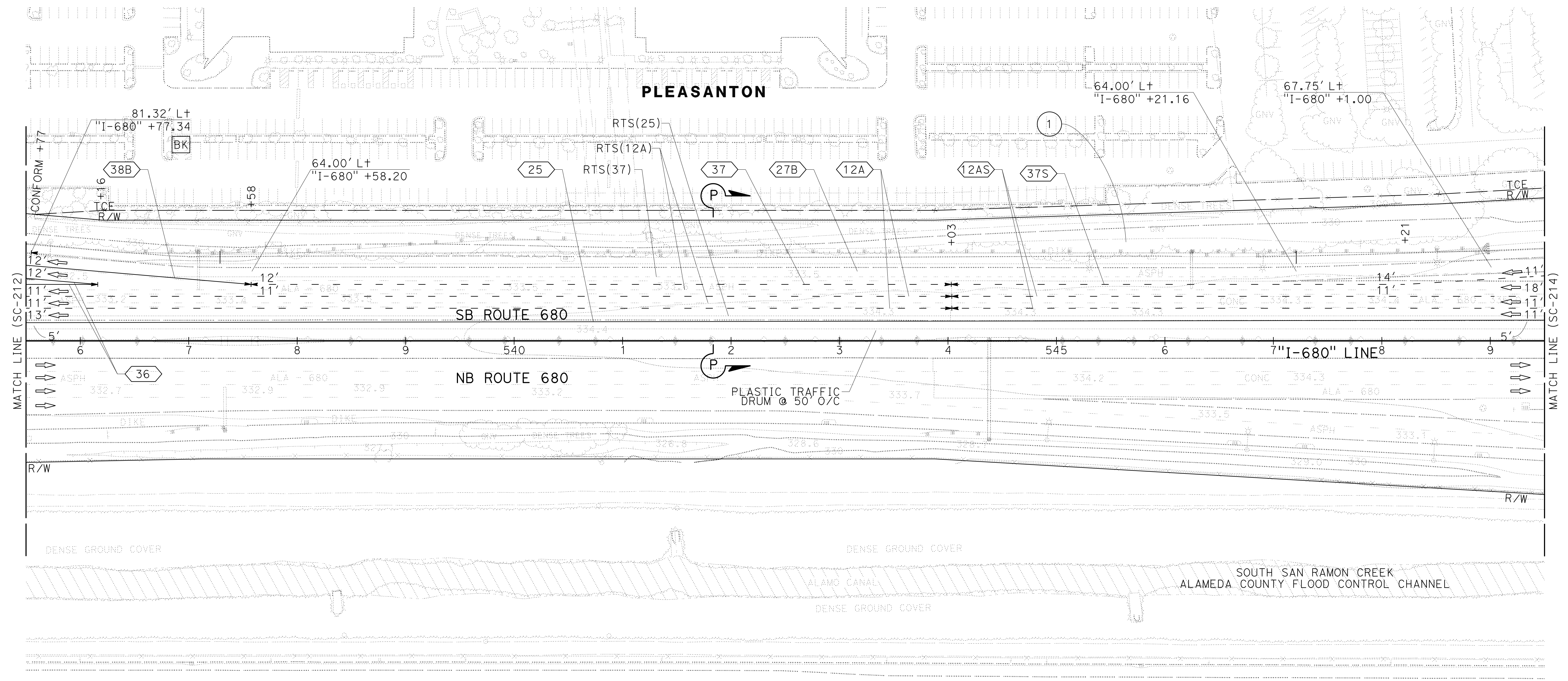



FOR NOTES, ABBREVIATIONS AND
LEGEND, SEE SHEET SC-1 AND SC-186

APPROVED FOR STAGE CONSTRUCTION AND TRAFFIC HANDLING WORK ONLY

STAGE CONSTRUCTION AND TRAFFIC HANDLING PLAN STAGE 4

SCALE: 1" = 50'

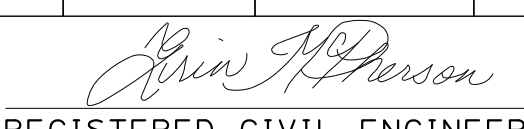
SC-213

Dist	COUNTY	ROUTE	POST MILES TOTAL PROJECT	SHEET No.	TOTAL SHEETS
04	Ala, CC	680	R11.0/R21.9, RO.0/RO.9	727	1710
 REGISTERED CIVIL ENGINEER			9-29-21 DATE		
October 8, 2021 PLANS APPROVAL DATE					
<small>THE STATE OF CALIFORNIA OR ITS OFFICERS OR AGENTS SHALL NOT BE RESPONSIBLE FOR THE ACCURACY OR COMPLETENESS OF SCANNED COPIES OF THIS PLAN SHEET.</small>					
WMH CORPORATION 55 South Market St Suite 1200 San Jose, CA 95113			ALAMEDA CTC 1111 Broadway Suite 800 Oakland, CA 94607		

NOTE:
 FOR ACCURATE RIGHT OF WAY DATA, CONTACT
 RIGHT OF WAY ENGINEERING AT THE DISTRICT OFFICE.

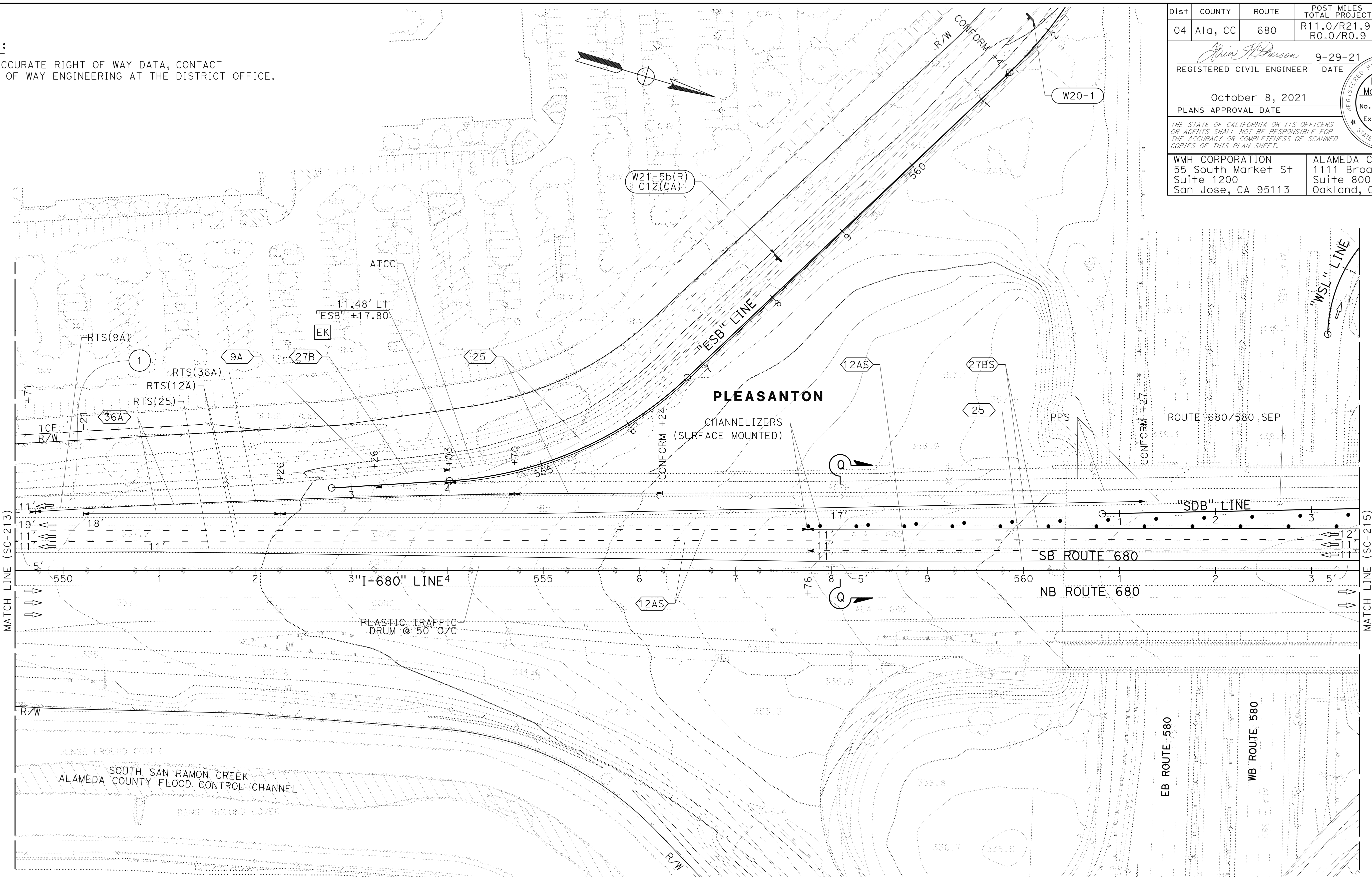

**STAGE CONSTRUCTION
 AND TRAFFIC HANDLING PLAN
 STAGE 4**

SCALE: 1" = 50'

SC-214

APPROVED FOR STAGE CONSTRUCTION AND TRAFFIC HANDLING WORK ONLY

FOR NOTES, ABBREVIATIONS AND
 LEGEND, SEE SHEET SC-1 AND SC-186

STATE OF CALIFORNIA - DEPARTMENT OF TRANSPORTATION	CONSULTANT	FUNCTIONAL SUPERVISOR	DESIGNED BY	CHECKED BY	REVISOR	DATE
	TIMOTHY J. LEE	JAMEY VALDIVIA	ERIN MCPHERSON	JV	9-29-21	

Dist	COUNTY	ROUTE	POST MILES TOTAL PROJECT	SHEET No.	TOTAL SHEETS
04	Ala, CC	680	R11.0/R21.9, RO.0/RO.9	728	1710
			REGISTERED CIVIL ENGINEER	DATE	
			ERIN D. McPHERSON	9-29-21	
			PLANS APPROVAL DATE		
			October 8, 2021		
<small>THE STATE OF CALIFORNIA OR ITS OFFICERS OR AGENTS SHALL NOT BE RESPONSIBLE FOR THE ACCURACY OR COMPLETENESS OF SCANNED COPIES OF THIS PLAN SHEET.</small>					
WMH CORPORATION			ALAMEDA CTC		
55 South Market St			1111 Broadway		
San Jose, CA 95113			Suite 800		
			Oakland, CA 94607		

NOTE:
FOR ACCURATE RIGHT OF WAY DATA, CONTACT RIGHT OF WAY ENGINEERING AT THE DISTRICT OFFICE.

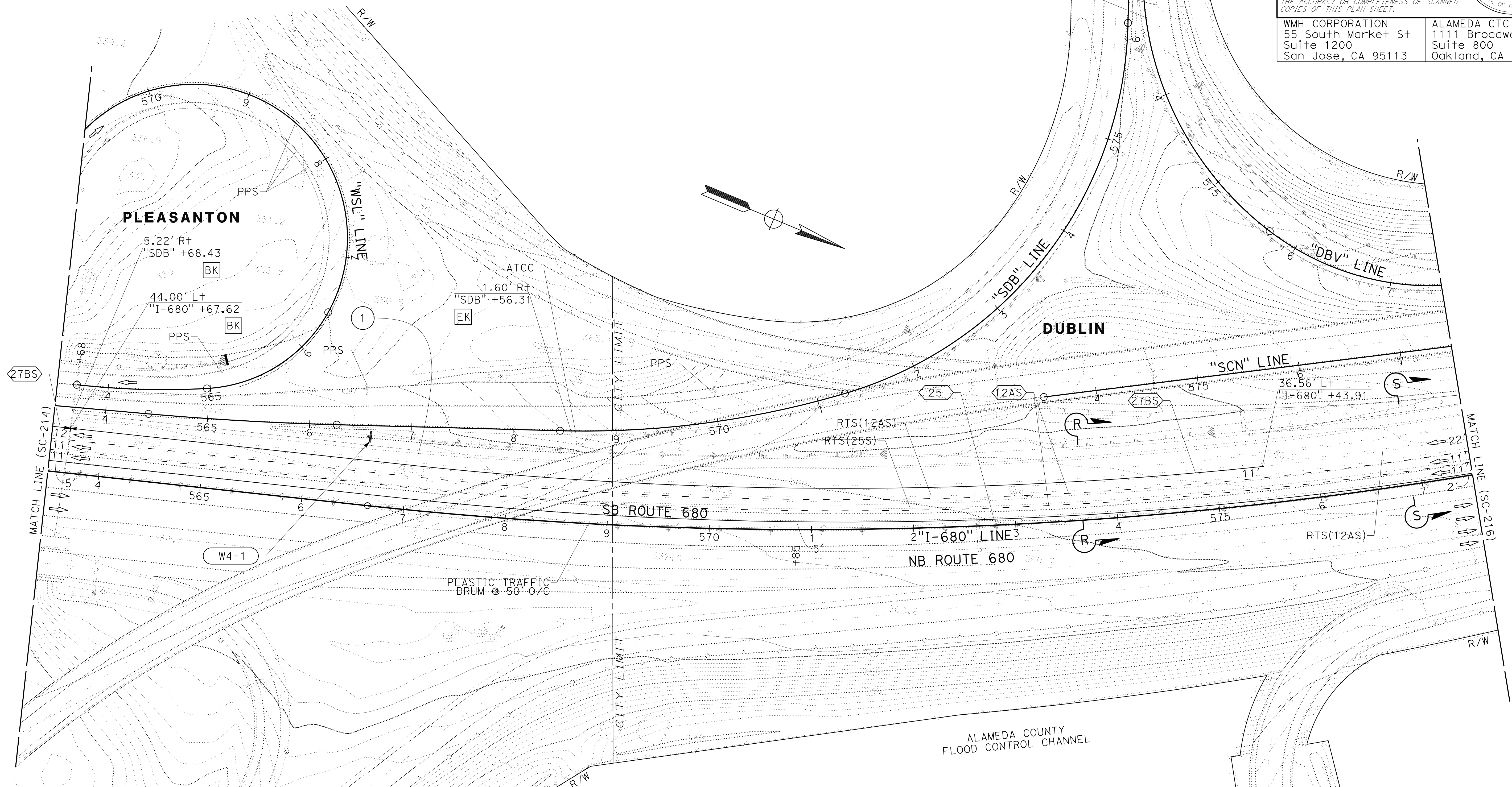

FOR NOTES, ABBREVIATIONS AND LEGEND, SEE SHEET SC-1 AND SC-186

APPROVED FOR STAGE CONSTRUCTION AND TRAFFIC HANDLING WORK ONLY

**STAGE CONSTRUCTION AND TRAFFIC HANDLING PLAN
STAGE 4**

SCALE: 1" = 50'

SC-215

STATE OF CALIFORNIA - DEPARTMENT OF TRANSPORTATION	CALCULATED/DESIGNED BY	REVISOR	DATE
Ervin Corporation	JAMIE VALDIVIA	JV	9-29-21
	ERIN McPHERSON		
	TIMOTHY J. LEE		

Dist	COUNTY	ROUTE	POST MILES TOTAL PROJECT	SHEET No.	TOTAL SHEETS
04	Ala, CC	680	R11.0/R21.9, RO.0/RO.9	729	1710

ERIN D. McPHERSON
 REGISTERED CIVIL ENGINEER
 No. C91111
 Exp. 3-31-24
 CIVIL
 STATE OF CALIFORNIA

9-29-21
 DATE
 October 8, 2021
 PLANS APPROVAL DATE

THE STATE OF CALIFORNIA OR ITS OFFICERS OR AGENTS SHALL NOT BE RESPONSIBLE FOR THE ACCURACY OR COMPLETENESS OF SCANNED COPIES OF THIS PLAN SHEET.

WMH CORPORATION
 55 South Market St
 Suite 1200
 San Jose, CA 95113

ALAMEDA CTC
 1111 Broadway
 Suite 800
 Oakland, CA 94607

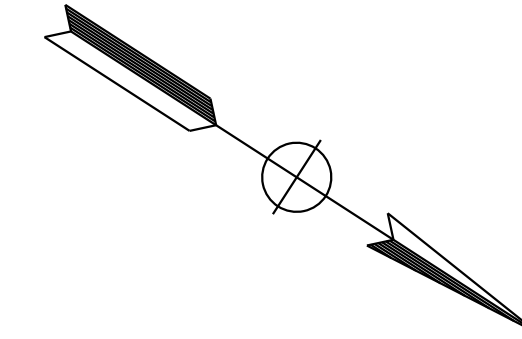

NOTE:
 FOR ACCURATE RIGHT OF WAY DATA, CONTACT RIGHT OF WAY ENGINEERING AT THE DISTRICT OFFICE.

STATE OF CALIFORNIA - DEPARTMENT OF TRANSPORTATION
 Er Catrans
 CONSULTANT: JAMIEY VALDIVIA
 CHECKED BY: ERIN MCPHERSON
 CONSULTANT: ERIN MCPHERSON
 SUPERVISOR: TIMOTHY J. LEE

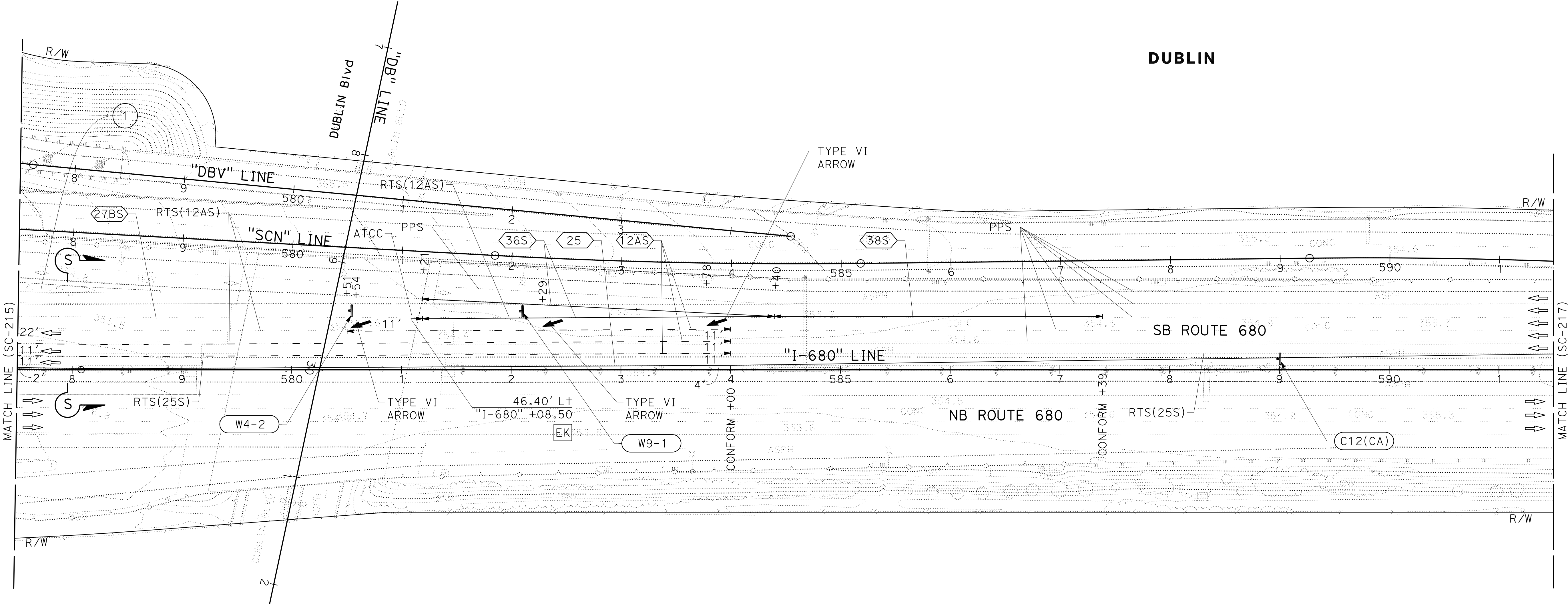

FOR NOTES, ABBREVIATIONS AND LEGEND, SEE SHEET SC-1 AND SC-186

STAGE CONSTRUCTION AND TRAFFIC HANDLING PLAN STAGE 4

SCALE: 1" = 50'

SC-216

APPROVED FOR STAGE CONSTRUCTION AND TRAFFIC HANDLING WORK ONLY

LAST REVISION: 09-29-21 TIME PLOTTED => 11:56
 DATE PLOTTED => 7-MAR-2022

Dist	COUNTY	ROUTE	POST MILES TOTAL PROJECT	SHEET No.	TOTAL SHEETS
04	Ala, CC	680	R11.0/R21.9, RO.0/RO.9	730	1710

REGISTERED CIVIL ENGINEER	DATE
<i>Erin D. McPherson</i>	9-29-21
October 8, 2021	
PLANS APPROVAL DATE	

REGISTERED PROFESSIONAL ENGINEER ERIN D. McPHERSON No. C91111 Exp. 3-31-24 CIVIL STATE OF CALIFORNIA
--

WMH CORPORATION 55 South Market St Suite 1200 San Jose, CA 95113	ALAMEDA CTC 1111 Broadway Suite 800 Oakland, CA 94607
---	--

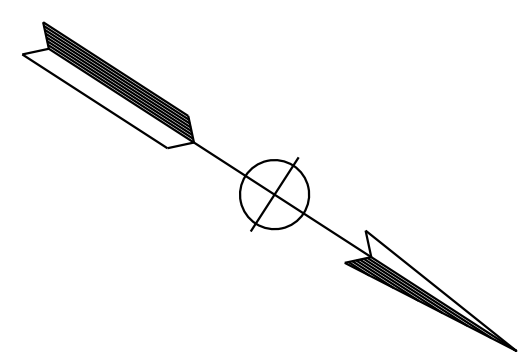

NOTE:
FOR ACCURATE RIGHT OF WAY DATA, CONTACT
RIGHT OF WAY ENGINEERING AT THE DISTRICT OFFICE.

STATE OF CALIFORNIA - DEPARTMENT OF TRANSPORTATION	CONSULTANT FUNCTIONAL SUPERVISOR	DESIGNED BY	REVISOR	DATE
	TIMOTHY J. LEE	JAMIEY VALDIVIA	JV	9-29-21
		ERIN McPHERSON		

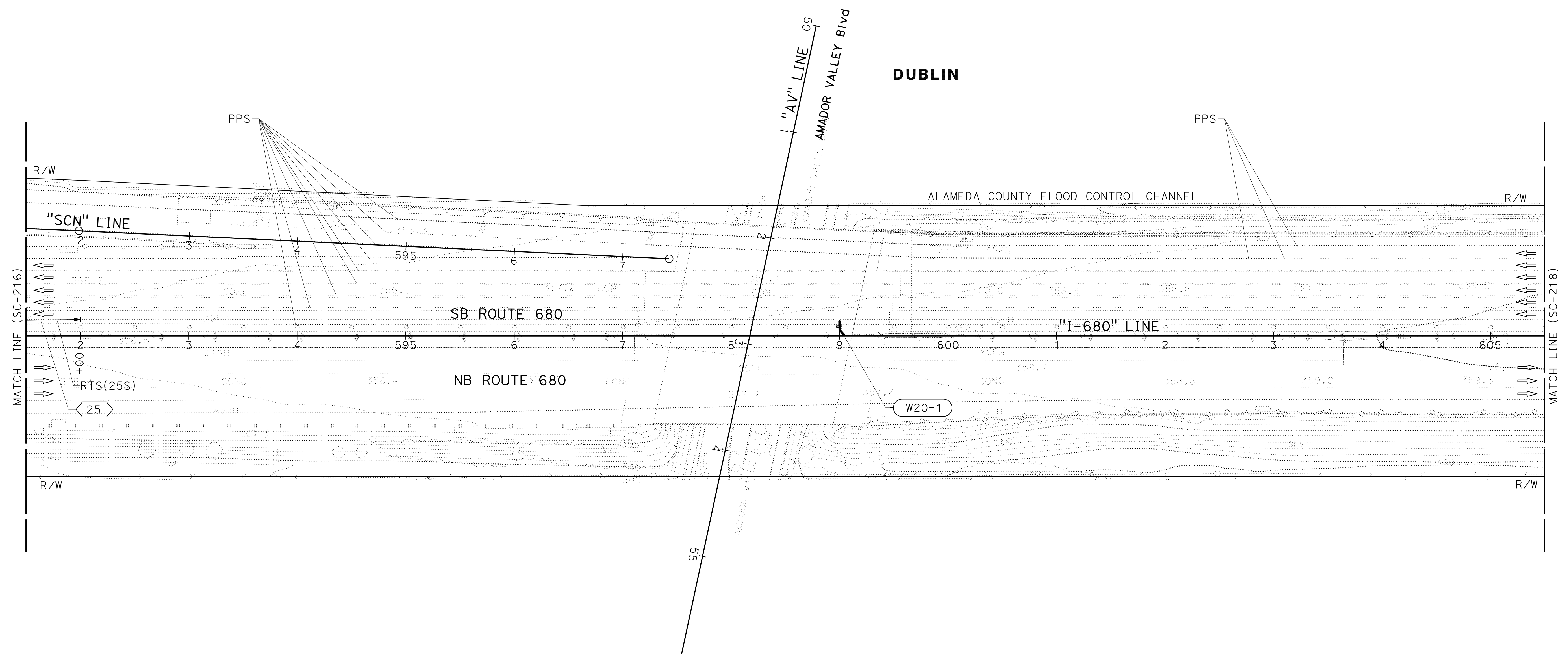

FOR NOTES, ABBREVIATIONS AND
LEGEND, SEE SHEET SC-1 AND SC-186

APPROVED FOR STAGE CONSTRUCTION AND TRAFFIC HANDLING WORK ONLY

STAGE CONSTRUCTION AND TRAFFIC HANDLING PLAN STAGE 4

SCALE: 1" = 50'

SC-217

LAST REVISION: 09-29-21 DATE PLOTTED => 7-MAR-2022 TIME PLOTTED => 11:56

Dist	COUNTY	ROUTE	POST MILES TOTAL PROJECT	SHEET No.	TOTAL SHEETS
04	Ala, CC	680	R11.0/R21.9, RO.0/RO.9	731	1710

9-29-21
 REGISTERED CIVIL ENGINEER DATE
 October 8, 2021
 PLANS APPROVAL DATE

ERIN D. McPHERSON
 No. C91111
 Exp. 3-31-24
 CIVIL
 STATE OF CALIFORNIA

THE STATE OF CALIFORNIA OR ITS OFFICERS OR AGENTS SHALL NOT BE RESPONSIBLE FOR THE ACCURACY OR COMPLETENESS OF SCANNED COPIES OF THIS PLAN SHEET.

WMH CORPORATION 55 South Market St Suite 1200 San Jose, CA 95113	ALAMEDA CTC 1111 Broadway Suite 800 Oakland, CA 94607
---	--

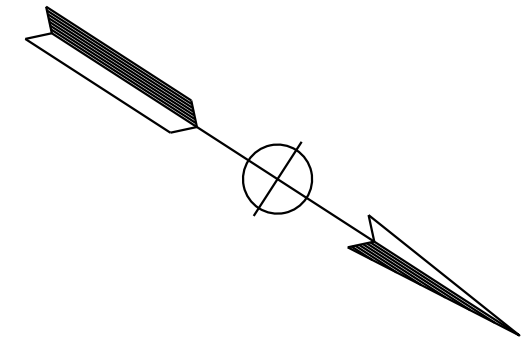

NOTE:
FOR ACCURATE RIGHT OF WAY DATA, CONTACT
RIGHT OF WAY ENGINEERING AT THE DISTRICT OFFICE.

REVISED BY	DATE REVISED	CALCULATED-DESIGNED BY	CHECKED BY	CONSULTANT FUNCTIONAL SUPERVISOR	DEPARTMENT OF TRANSPORTATION
JV	9-29-21	JAMEY VALDIVIA	ERIN McPHERSON	TIMOTHY J. LEE	STATE OF CALIFORNIA - DEPARTMENT OF TRANSPORTATION

DUBLIN

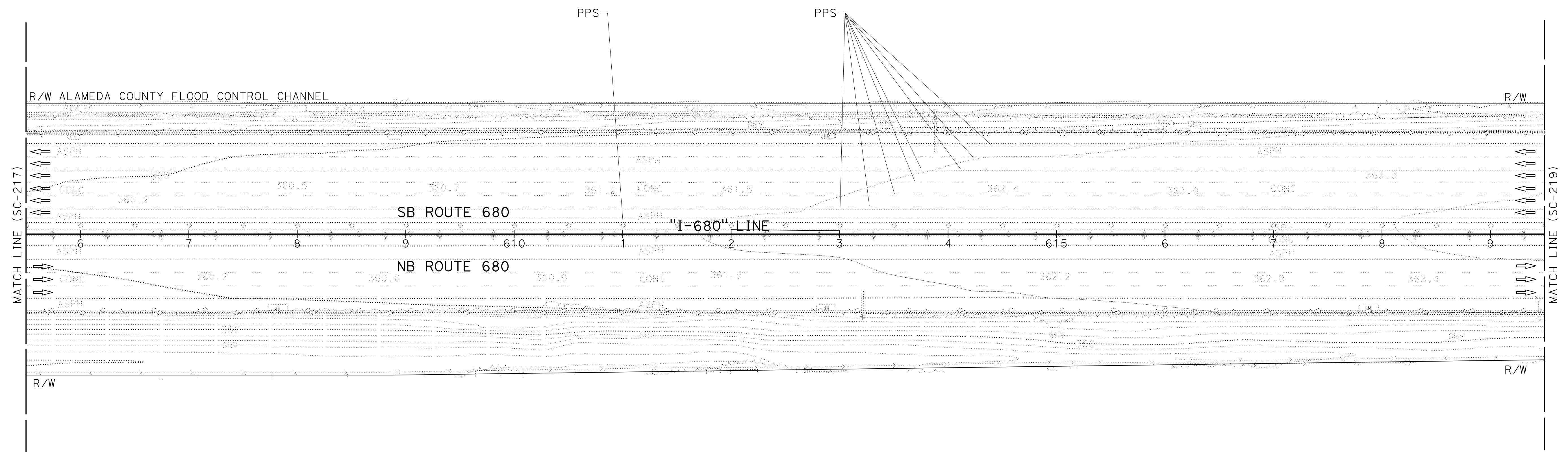

FOR NOTES, ABBREVIATIONS AND
LEGEND, SEE SHEET SC-1 AND SC-186

APPROVED FOR STAGE CONSTRUCTION AND TRAFFIC HANDLING WORK ONLY

**STAGE CONSTRUCTION
AND TRAFFIC HANDLING PLAN
STAGE 4**

SCALE: 1" = 50'

SC-218

LAST REVISION: 09-29-21 DATE PLOTTED => 7-MAR-2022 TIME PLOTTED => 11:56

Dist	COUNTY	ROUTE	POST MILES TOTAL PROJECT	SHEET No.	TOTAL SHEETS
04	Ala, CC	680	R11.0/R21.9, RO.0/RO.9	732	1710
			9-29-21		
REGISTERED CIVIL ENGINEER			DATE		
			October 8, 2021		
			PLANS APPROVAL DATE		
WMH CORPORATION 55 South Market St Suite 1200 San Jose, CA 95113			ALAMEDA CTC 1111 Broadway Suite 800 Oakland, CA 94607		

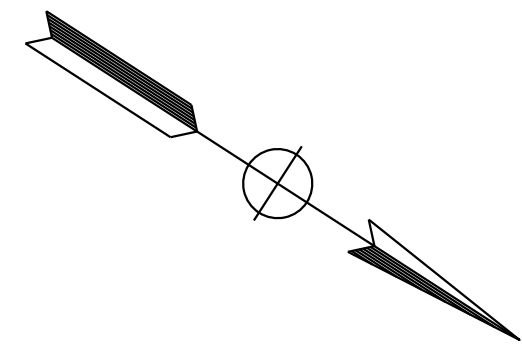

NOTE:
FOR ACCURATE RIGHT OF WAY DATA, CONTACT
RIGHT OF WAY ENGINEERING AT THE DISTRICT OFFICE.

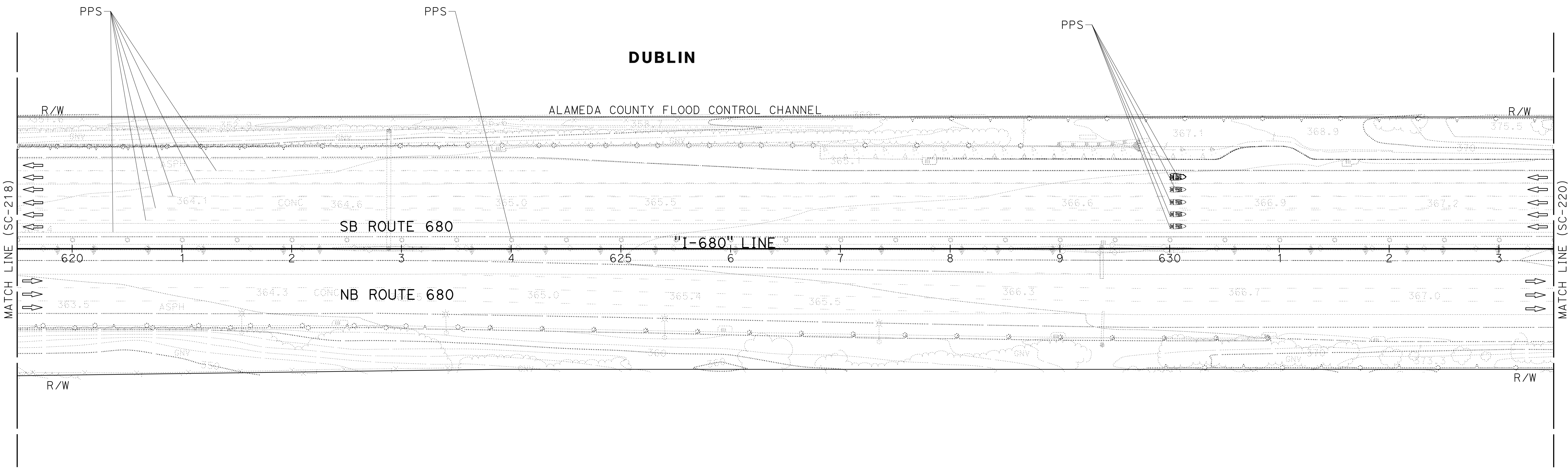

**STAGE CONSTRUCTION
AND TRAFFIC HANDLING PLAN
STAGE 4**

SCALE: 1" = 50'

SC-219

APPROVED FOR STAGE CONSTRUCTION AND TRAFFIC HANDLING WORK ONLY

FOR NOTES, ABBREVIATIONS AND
LEGEND, SEE SHEET SC-1 AND SC-186

STATE OF CALIFORNIA - DEPARTMENT OF TRANSPORTATION	CONSULTANT	FUNCTIONAL SUPERVISOR	CALCULATED-DESIGNED BY	REVISOR	DATE
	TIMOTHY J. LEE	JAMEY VALDIVIA	ERIN McPHERSON	JV	9-29-21

Dist	COUNTY	ROUTE	POST MILES TOTAL PROJECT	SHEET No.	TOTAL SHEETS
04	Ala, CC	680	R11.0/R21.9, R0.0/R0.9	733	1710
			9-29-21		
REGISTERED CIVIL ENGINEER			DATE		
October 8, 2021			PLANS APPROVAL DATE		
<small>THE STATE OF CALIFORNIA OR ITS OFFICERS OR AGENTS SHALL NOT BE RESPONSIBLE FOR THE ACCURACY OR COMPLETENESS OF SCANNED COPIES OF THIS PLAN SHEET.</small>					
WMH CORPORATION 55 South Market St Suite 1200 San Jose, CA 95113			ALAMEDA CTC 1111 Broadway Suite 800 Oakland, CA 94607		

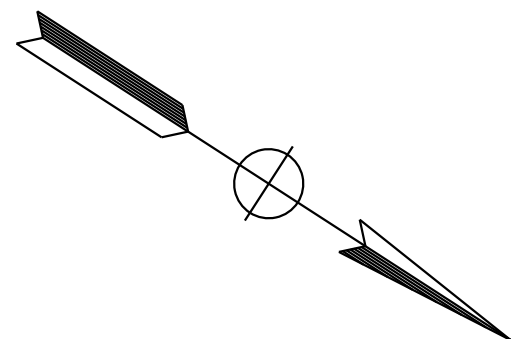

NOTE:
FOR ACCURATE RIGHT OF WAY DATA, CONTACT
RIGHT OF WAY ENGINEERING AT THE DISTRICT OFFICE.

STATE OF CALIFORNIA - DEPARTMENT OF TRANSPORTATION	CONSULTANT	FUNCTIONAL SUPERVISOR	CALCULATED- DESIGNED BY	JAMEY VALDIVIA	REVISOR	DATE
	TIMOTHY J. LEE	JV	ERIN MCPHERSON	9-29-21		

DUBLIN

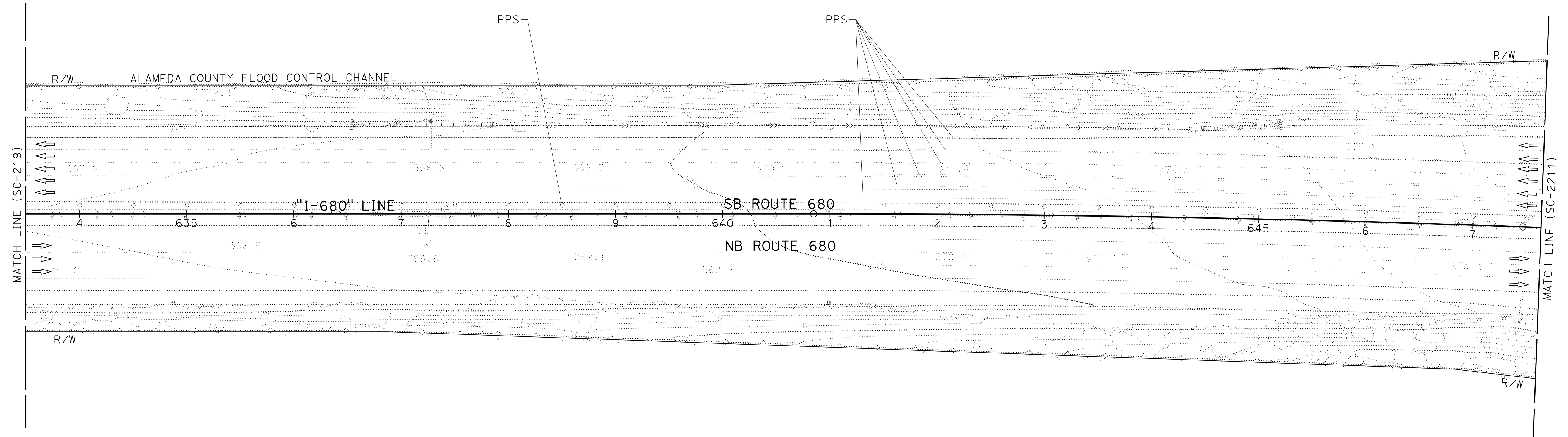

**STAGE CONSTRUCTION
AND TRAFFIC HANDLING PLAN
STAGE 4**

SCALE: 1" = 50'

SC-220

FOR NOTES, ABBREVIATIONS AND
LEGEND, SEE SHEET SC-1 AND SC-186

APPROVED FOR STAGE CONSTRUCTION AND TRAFFIC HANDLING WORK ONLY

LAST REVISION: 09-29-21 DATE PLOTTED => 7-MAR-2022 TIME PLOTTED => 11:56

Dist	COUNTY	ROUTE	POST MILES TOTAL PROJECT	SHEET No.	TOTAL SHEETS
04	Ala, CC	680	R11.0/R21.9, RO.0/RO.9	734	1710
			9-29-21		
REGISTERED CIVIL ENGINEER			DATE		
October 8, 2021			PLANS APPROVAL DATE		
WMH CORPORATION 55 South Market St Suite 1200 San Jose, CA 95113			ALAMEDA CTC 1111 Broadway Suite 800 Oakland, CA 94607		

NOTE:
FOR ACCURATE RIGHT OF WAY DATA, CONTACT
RIGHT OF WAY ENGINEERING AT THE DISTRICT OFFICE.

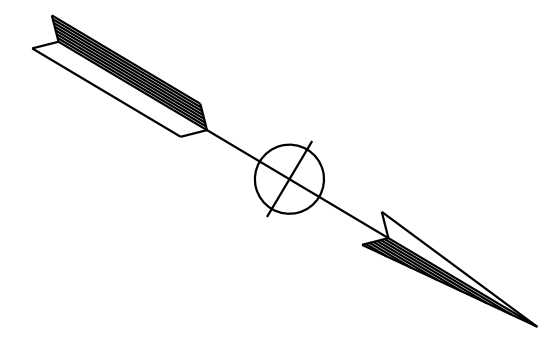

REVISOR	DATE	REVISION
JV	9-29-21	
CALCULATED-DESIGNED BY: JAMEY VALDIVIA CHECKED BY: ERIN MCPHERSON CONSULTANT SUPERVISOR: TIMOTHY J. LEE DEPARTMENT OF TRANSPORTATION: CALTRANS		

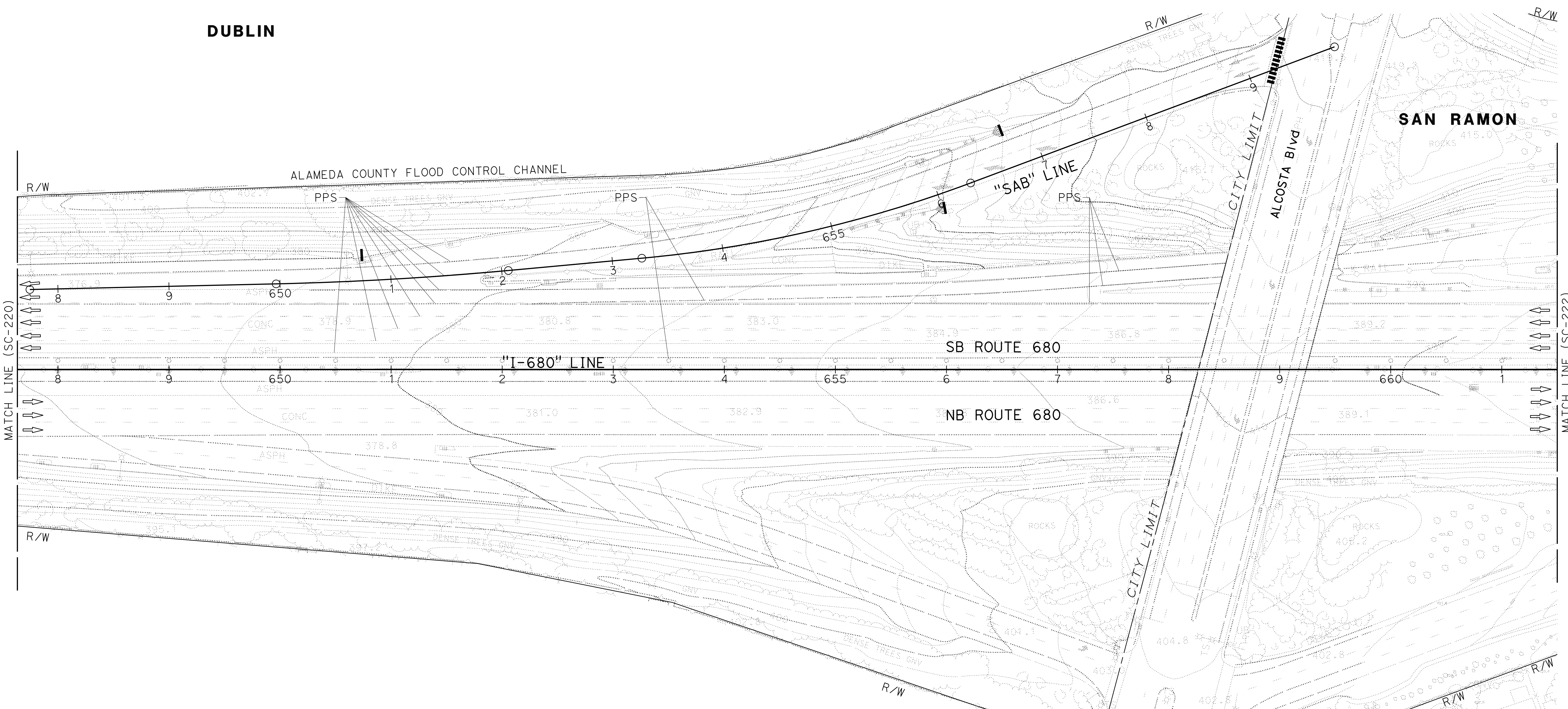

**STAGE CONSTRUCTION
AND TRAFFIC HANDLING PLAN
STAGE 4**

SCALE: 1" = 50'

SC-221

FOR NOTES, ABBREVIATIONS AND
LEGEND, SEE SHEET SC-1 AND SC-186

APPROVED FOR STAGE CONSTRUCTION AND TRAFFIC HANDLING WORK ONLY

LAST REVISION: 09-29-21 DATE PLOTTED => 7-MAR-2022 TIME PLOTTED => 11:57

Dist	COUNTY	ROUTE	POST MILES TOTAL PROJECT	SHEET No.	TOTAL SHEETS
04	Ala, CC	680	R11.0/R21.9, RO.0/RO.9	735	1710
			9-29-21		
REGISTERED CIVIL ENGINEER			DATE		
October 8, 2021			PLANS APPROVAL DATE		
WMH CORPORATION 55 South Market St Suite 1200 San Jose, CA 95113			ALAMEDA CTC 1111 Broadway Suite 800 Oakland, CA 94607		

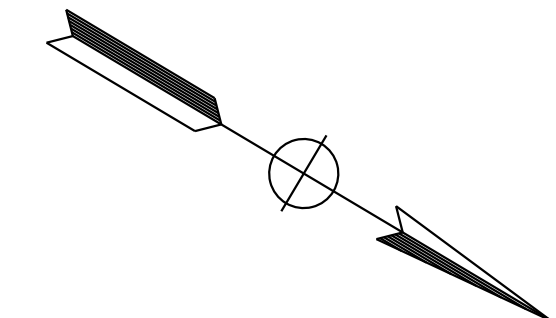

NOTE:
FOR ACCURATE RIGHT OF WAY DATA, CONTACT
RIGHT OF WAY ENGINEERING AT THE DISTRICT OFFICE.

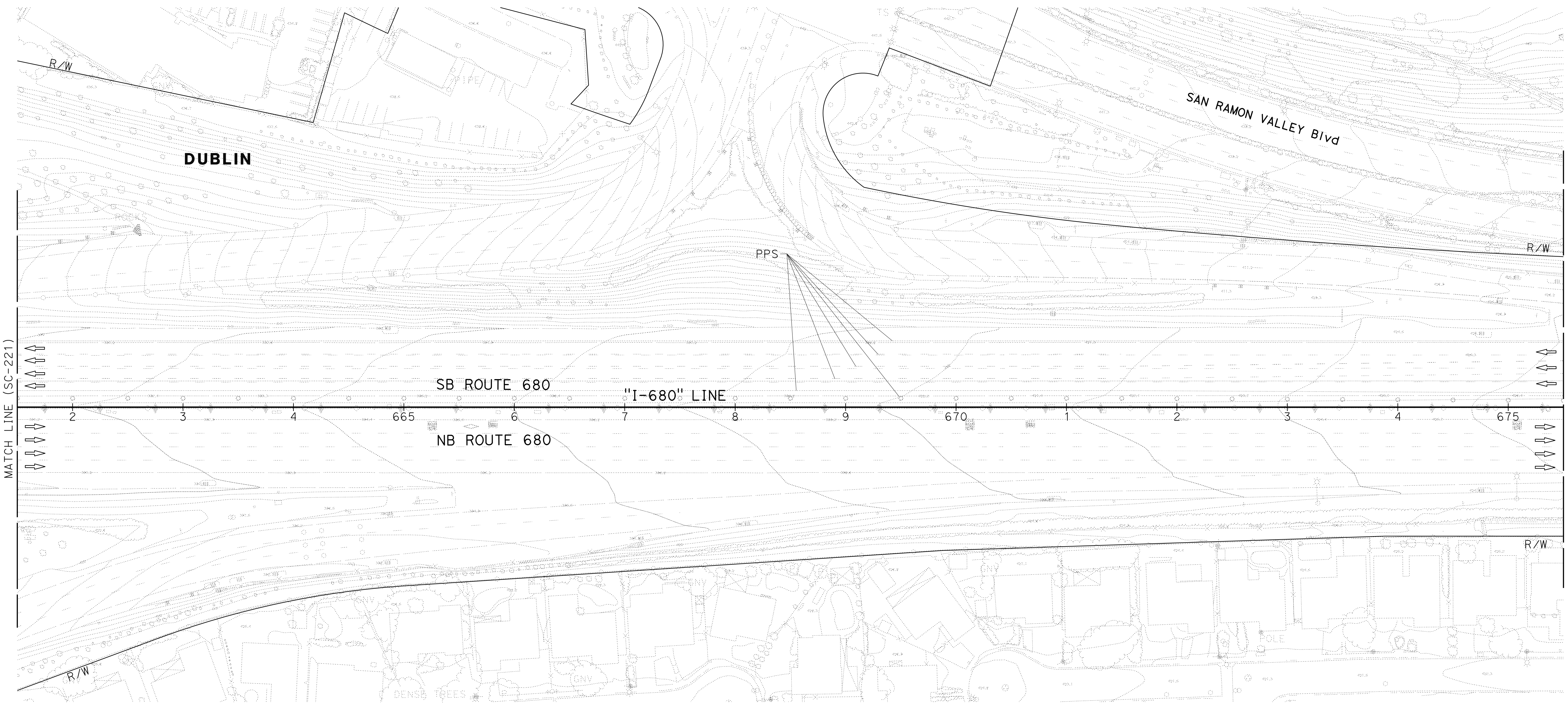

**STAGE CONSTRUCTION
AND TRAFFIC HANDLING PLAN
STAGE 4**

SCALE: 1" = 50'

SC-222

APPROVED FOR STAGE CONSTRUCTION AND TRAFFIC HANDLING WORK ONLY

FOR NOTES, ABBREVIATIONS AND
LEGEND, SEE SHEET SC-1 AND SC-186

STATE OF CALIFORNIA - DEPARTMENT OF TRANSPORTATION	CONSULTANT - FUNCTIONAL SUPERVISOR	CALCULATED-DESIGNED BY	REVISOR	DATE
Erwin	TIMOTHY J. LEE	JAMEY VALDIVIA	JV	9-29-21
		ERIN MCPHERSON		

Dist	COUNTY	ROUTE	POST MILES TOTAL PROJECT	SHEET No.	TOTAL SHEETS
04	Ala, CC	680	R11.0/R21.9, R0.0/R0.9	736	1710
			9-29-21		
REGISTERED CIVIL ENGINEER			DATE		
			October 8, 2021		
			PLANS APPROVAL DATE		
<small>THE STATE OF CALIFORNIA OR ITS OFFICERS OR AGENTS SHALL NOT BE RESPONSIBLE FOR THE ACCURACY OR COMPLETENESS OF SCANNED COPIES OF THIS PLAN SHEET.</small>					
WMH CORPORATION 55 South Market St Suite 1200 San Jose, CA 95113			ALAMEDA CTC 1111 Broadway Suite 800 Oakland, CA 94607		

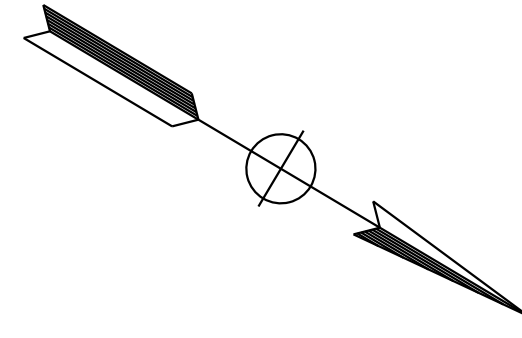

NOTE:
FOR ACCURATE RIGHT OF WAY DATA, CONTACT
RIGHT OF WAY ENGINEERING AT THE DISTRICT OFFICE.

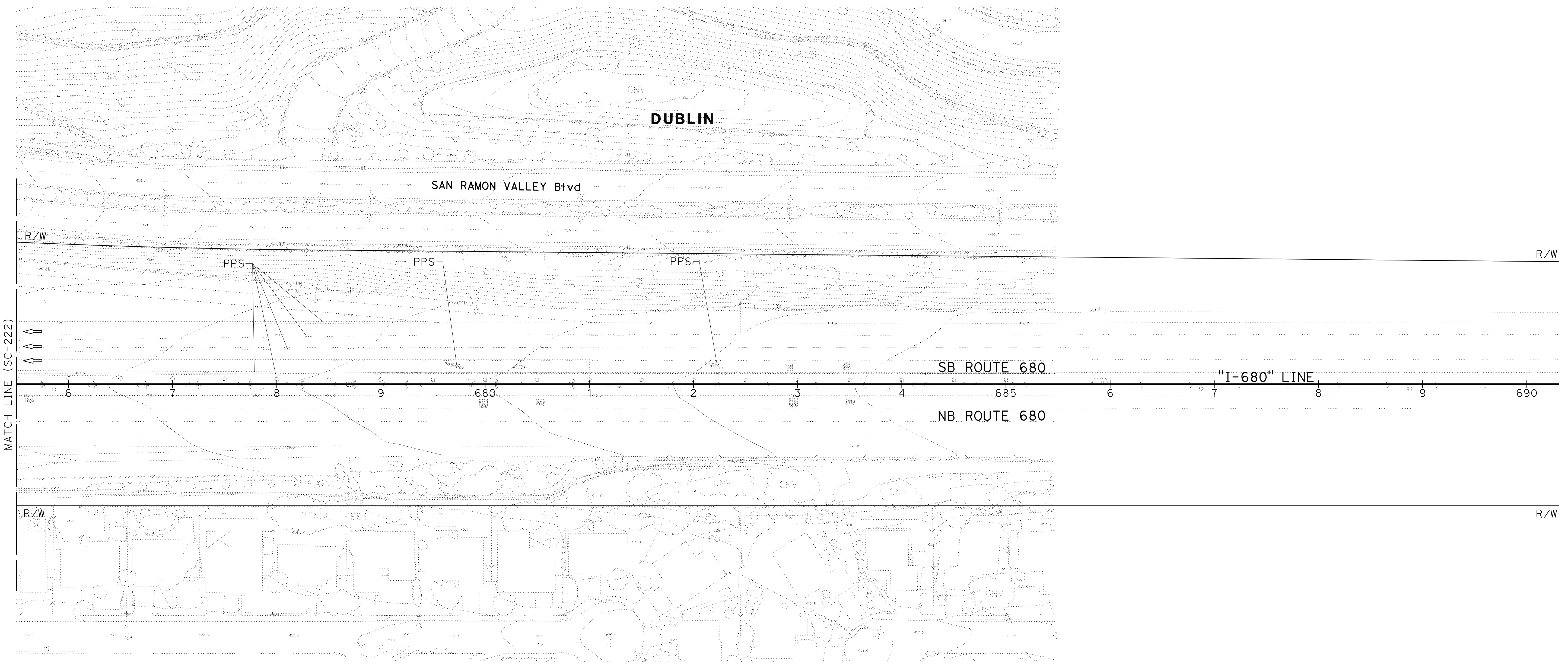

MATCH LINE (SC-222)

R/W

R/W

		JV	9-29-21				
		REVISOR	DATE				
	JAMEY VALDIVIA	ERIN McPHERSON					
	CALCULATED-DESIGNED BY	CHECKED BY					
	TIMOTHY J. LEE						
	CONSULTANT	FUNCTIONAL SUPERVISOR					
	DEPARTMENT OF TRANSPORTATION						
	STATE OF CALIFORNIA						

FOR NOTES, ABBREVIATIONS AND
LEGEND, SEE SHEET SC-1 AND SC-186

APPROVED FOR STAGE CONSTRUCTION AND TRAFFIC HANDLING WORK ONLY

**STAGE CONSTRUCTION
AND TRAFFIC HANDLING PLAN
STAGE 4**

SCALE: 1" = 50'

SC-223

LAST REVISION: DATE PLOTTED => 7-MAR-2022 TIME PLOTTED => 11:57

Dist	COUNTY	ROUTE	POST MILES TOTAL PROJECT	SHEET No.	TOTAL SHEETS
04	Ala, CC	680	R11.0/R21.9, RO.0/RO.9	737	1710
			9-29-21		
REGISTERED CIVIL ENGINEER			DATE		
			October 8, 2021		
			PLANS APPROVAL DATE		
<small>THE STATE OF CALIFORNIA OR ITS OFFICERS OR AGENTS SHALL NOT BE RESPONSIBLE FOR THE ACCURACY OR COMPLETENESS OF SCANNED COPIES OF THIS PLAN SHEET.</small>					
WMH CORPORATION 55 South Market St Suite 1200 San Jose, CA 95113			ALAMEDA CTC 1111 Broadway Suite 800 Oakland, CA 94607		

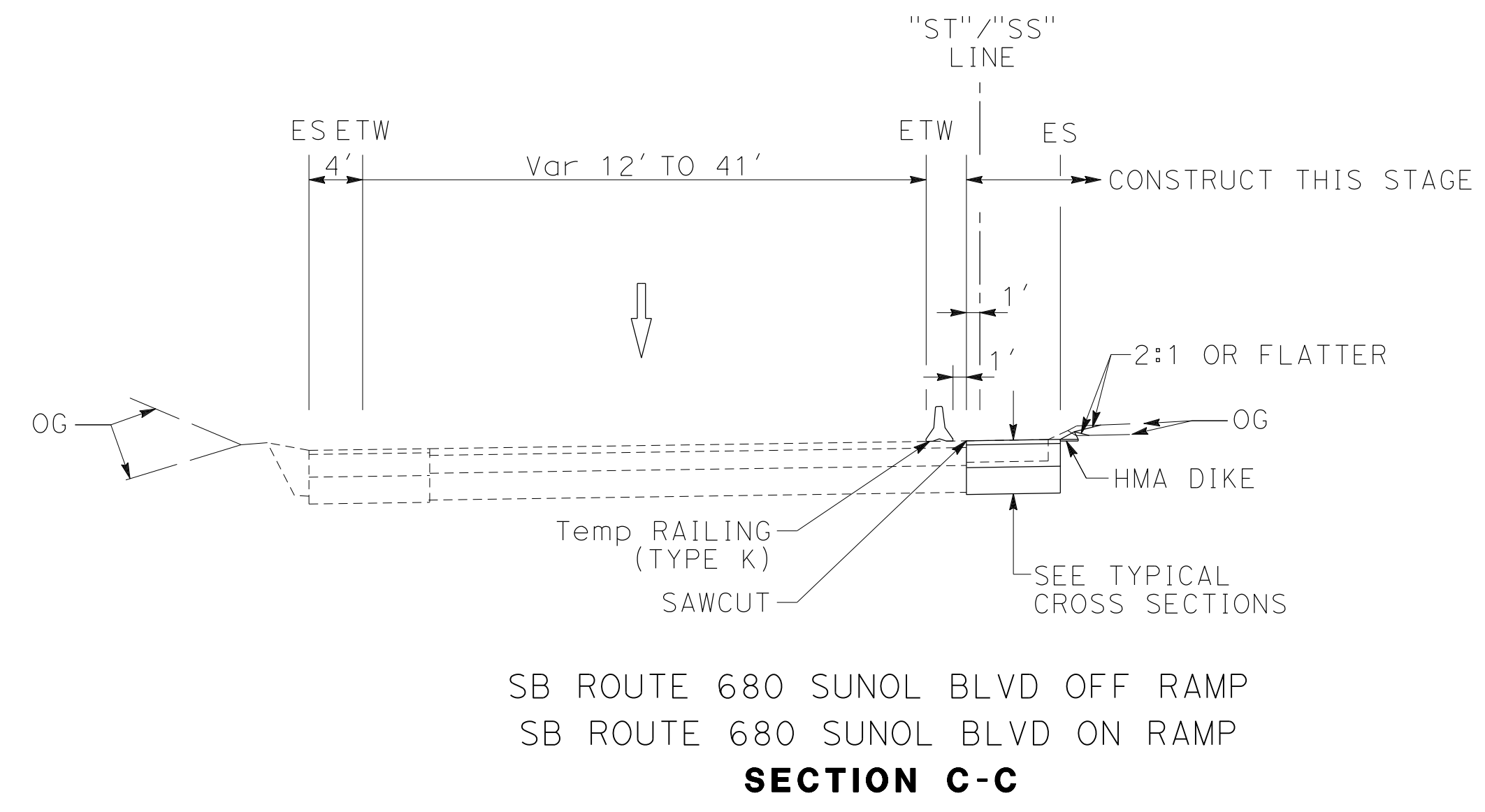
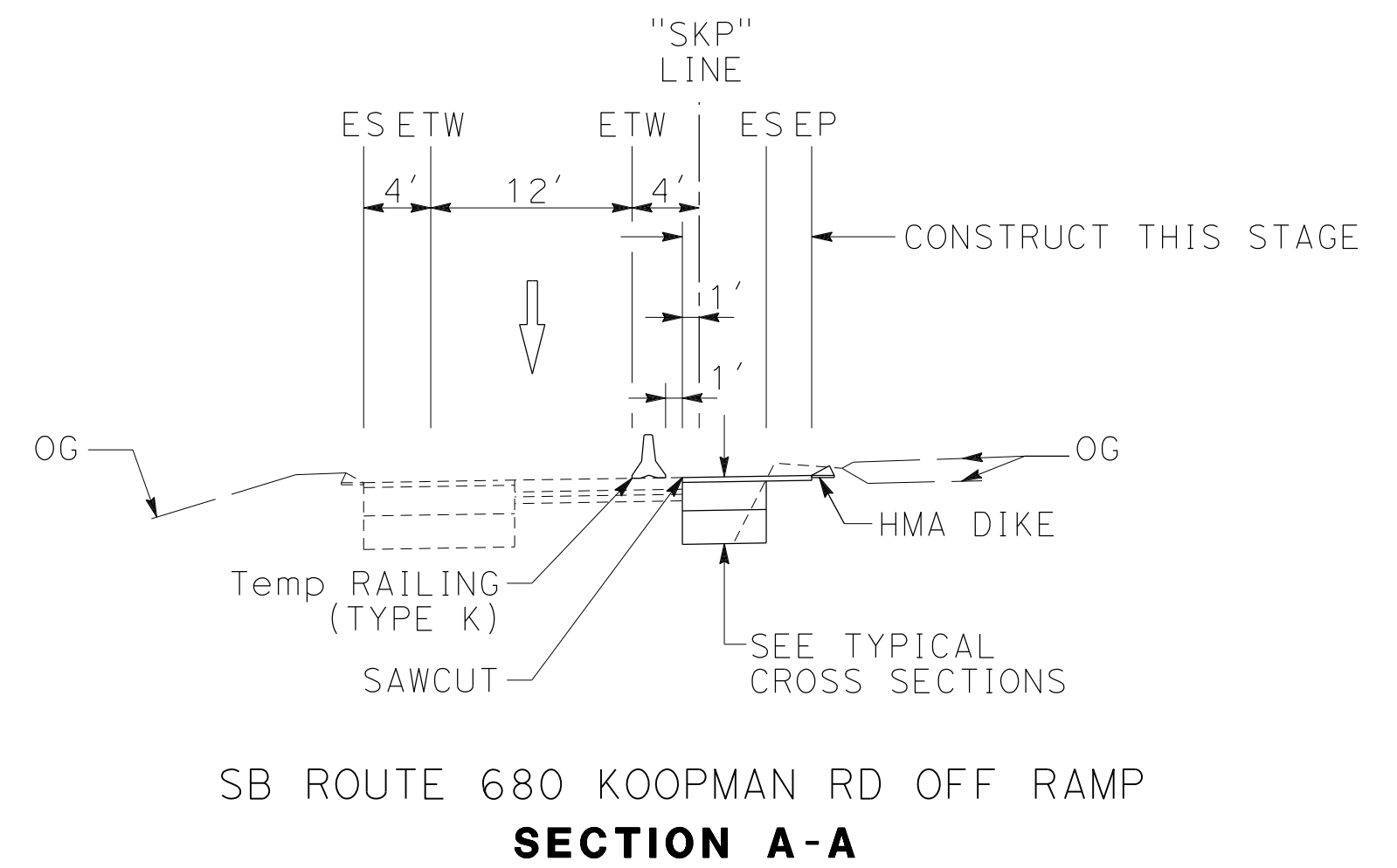
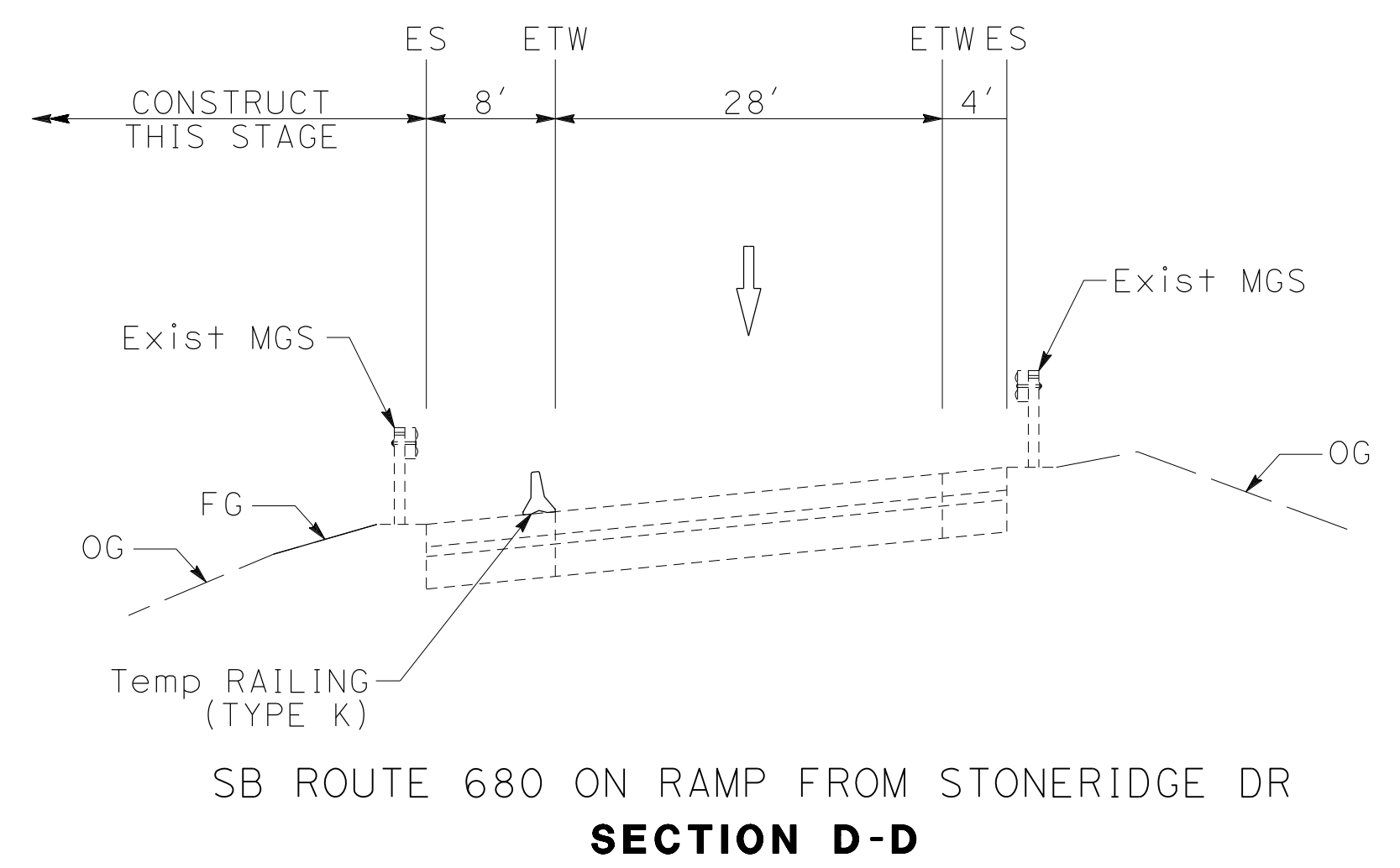
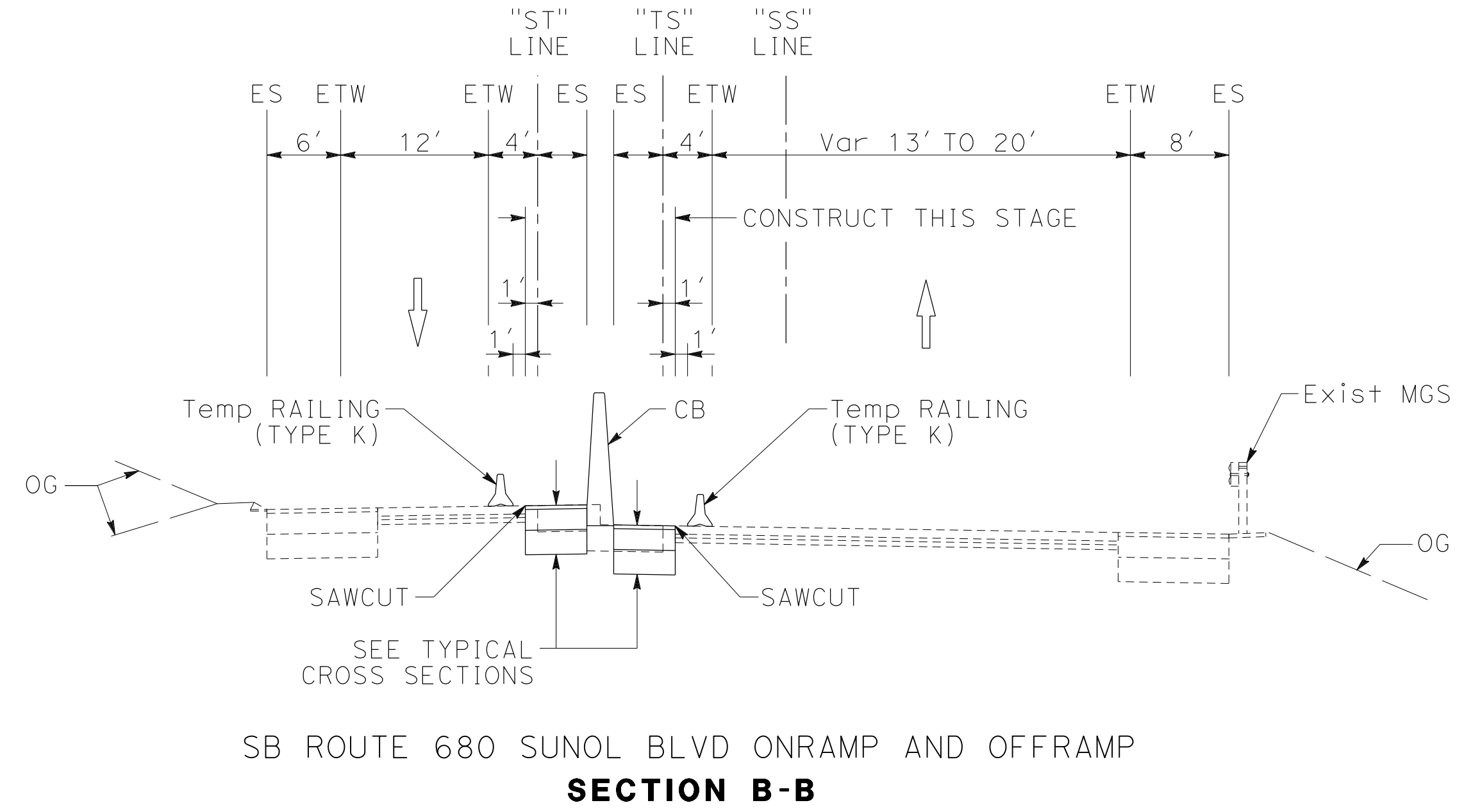

**STAGE CONSTRUCTION
AND TRAFFIC HANDLING PLAN
STAGE 5**

NO SCALE

SC-224

FOR NOTES, ABBREVIATIONS AND LEGEND, SEE SHEET SC-1 AND SC-226

X:\680_SB_GAP_EXPRESS\000_CAD\Submittal\11\11\CADD_submittal\0420000235ma224.dgn
 STATE OF CALIFORNIA - DEPARTMENT OF TRANSPORTATION
 CONSULTANT FUNCTIONAL SUPERVISOR: TIMOTHY J. LEE
 CALCULATED/DESIGNED BY: JAMEY VALDIVIA
 CHECKED BY: ERIN MCPHERSON
 REVISED BY: J.V. DATE REVISED: 9-29-21

Dist	COUNTY	ROUTE	POST MILES TOTAL PROJECT	SHEET No.	TOTAL SHEETS
04	Ala, CC	680	R11.0/R21.9, R0.0/R0.9	738	1710
			9-29-21		
REGISTERED CIVIL ENGINEER			DATE		
			October 8, 2021		
PLANS APPROVAL DATE					
<small>THE STATE OF CALIFORNIA OR ITS OFFICERS OR AGENTS SHALL NOT BE RESPONSIBLE FOR THE ACCURACY OR COMPLETENESS OF SCANNED COPIES OF THIS PLAN SHEET.</small>					
WMH CORPORATION 55 South Market St Suite 1200 San Jose, CA 95113			ALAMEDA CTC 1111 Broadway Suite 800 Oakland, CA 94607		

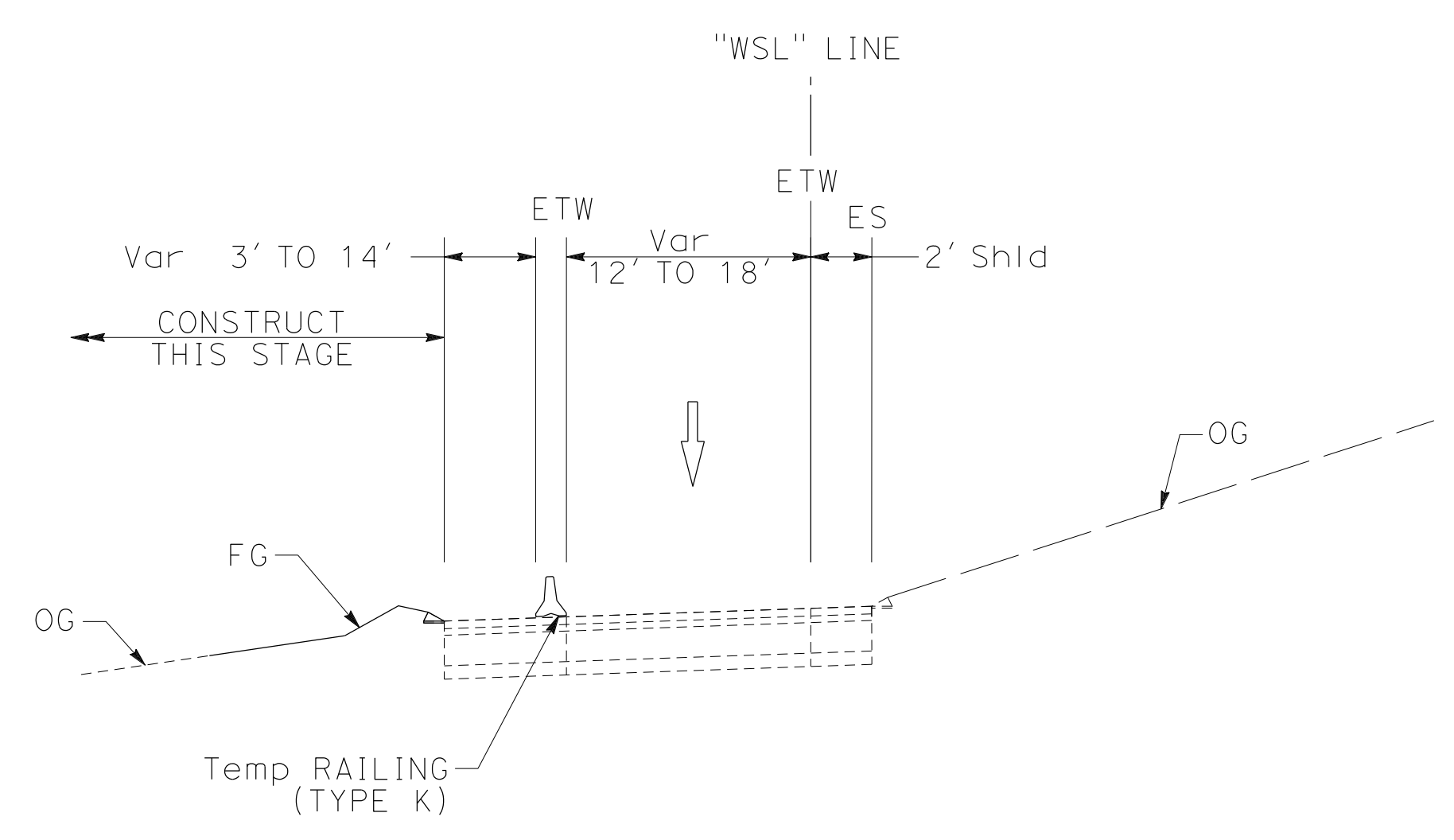

WB ROUTE 580 OFF RAMP TO SB ROUTE 680
SECTION F-F

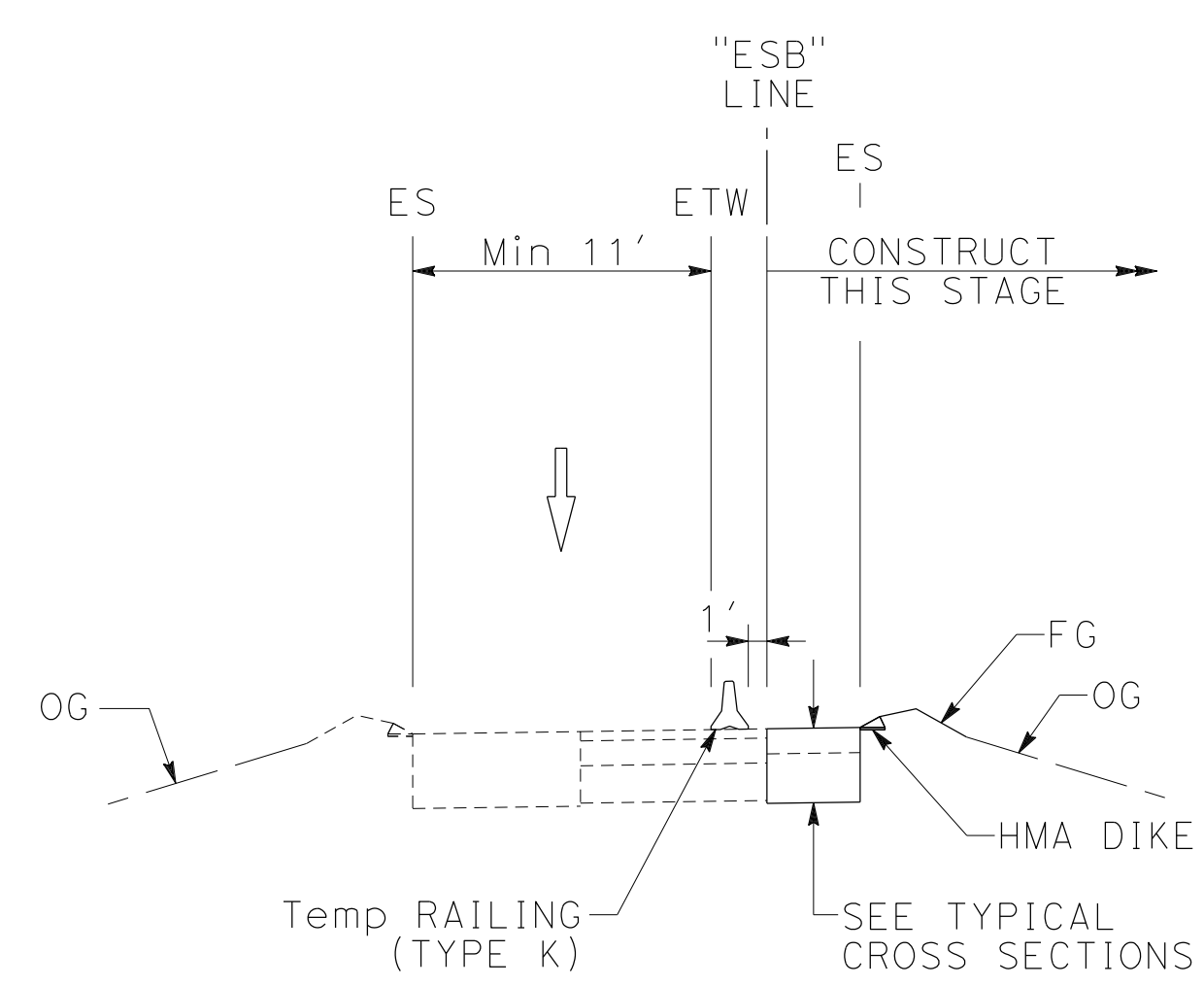

EB ROUTE 580 OFF RAMP TO SB ROUTE 680
SECTION E-E

**STAGE CONSTRUCTION
AND TRAFFIC HANDLING PLAN
STAGE 5**

NO SCALE

SC-225

FOR NOTES, ABBREVIATIONS AND
LEGEND, SEE SHEET SC-1 AND SC-226

CALIFORNIA	DEPARTMENT OF TRANSPORTATION	CONSULTANT	FUNCTIONAL SUPERVISOR	CALCULATED- DESIGNED BY	REVISOR	DATE
STATE OF CALIFORNIA	DEPARTMENT OF TRANSPORTATION	TIMOTHY J. LEE	JAMEY VALDIVIA	ERIN MCPHERSON	JV	9-29-21

LAST REVISION DATE PLOTTED => 3/18/2022
09-29-21 TIME PLOTTED => 4:44:21 PM

Dist	COUNTY	ROUTE	POST MILES TOTAL PROJECT	SHEET No.	TOTAL SHEETS
04	Ala, CC	680	R11.0/R21.9, R0.0/R0.9	739	1710
			9-29-21		
ERIN D. McPHERSON			DATE		
REGISTERED CIVIL ENGINEER			October 8, 2021		
			PLANS APPROVAL DATE		
<small>THE STATE OF CALIFORNIA OR ITS OFFICERS OR AGENTS SHALL NOT BE RESPONSIBLE FOR THE ACCURACY OR COMPLETENESS OF SCANNED COPIES OF THIS PLAN SHEET.</small>					
WMH CORPORATION 55 South Market St Suite 1200 San Jose, CA 95113			ALAMEDA CTC 1111 Broadway Suite 800 Oakland, CA 94607		



NOTES:

- FOR ACCURATE RIGHT OF WAY DATA, CONTACT RIGHT OF WAY ENGINEERING AT THE DISTRICT OFFICE.
- ALL PAVEMENT DELINEATION SHOWN IS FINAL, UNLESS OTHERWISE NOTED. SEE PD SHEETS FOR DETAILS.

STAGE 5 CONSTRUCTION:

- REMOVE TEMPORARY WIDENING, WHERE APPLICABLE, AND PLACE PROPOSED RAMP WIDENING, DRAINAGE, AND GRADING.
- CONSTRUCT PROPOSED DRAINAGE, MGS, AND GRADING.
- CONSTRUCT BARRIER.

STAGE 5 TRAFFIC:

- MAINTAIN EXISTING TRAFFIC LANES

STAGE 5 DRAINAGE:

CONSTRUCT DRAINAGE SYSTEM ALONG R+ ES
STA "ST" 309+00 TO "ST" 315+00
STA "TS" 313+00 TO "TS" 317+00

CONSTRUCT DRAINAGE SYSTEMS **114 115 116 R13**

CONSTRUCT DRAINAGE SYSTEMS ALONG L+ ES
STA "WSL" 564+00 TO "WSL" 571+00
STA "I-680" 600+00 TO "I-680" 627+00

CONSTRUCT SYSTEMS **49 1**, AS NIGHT WORK

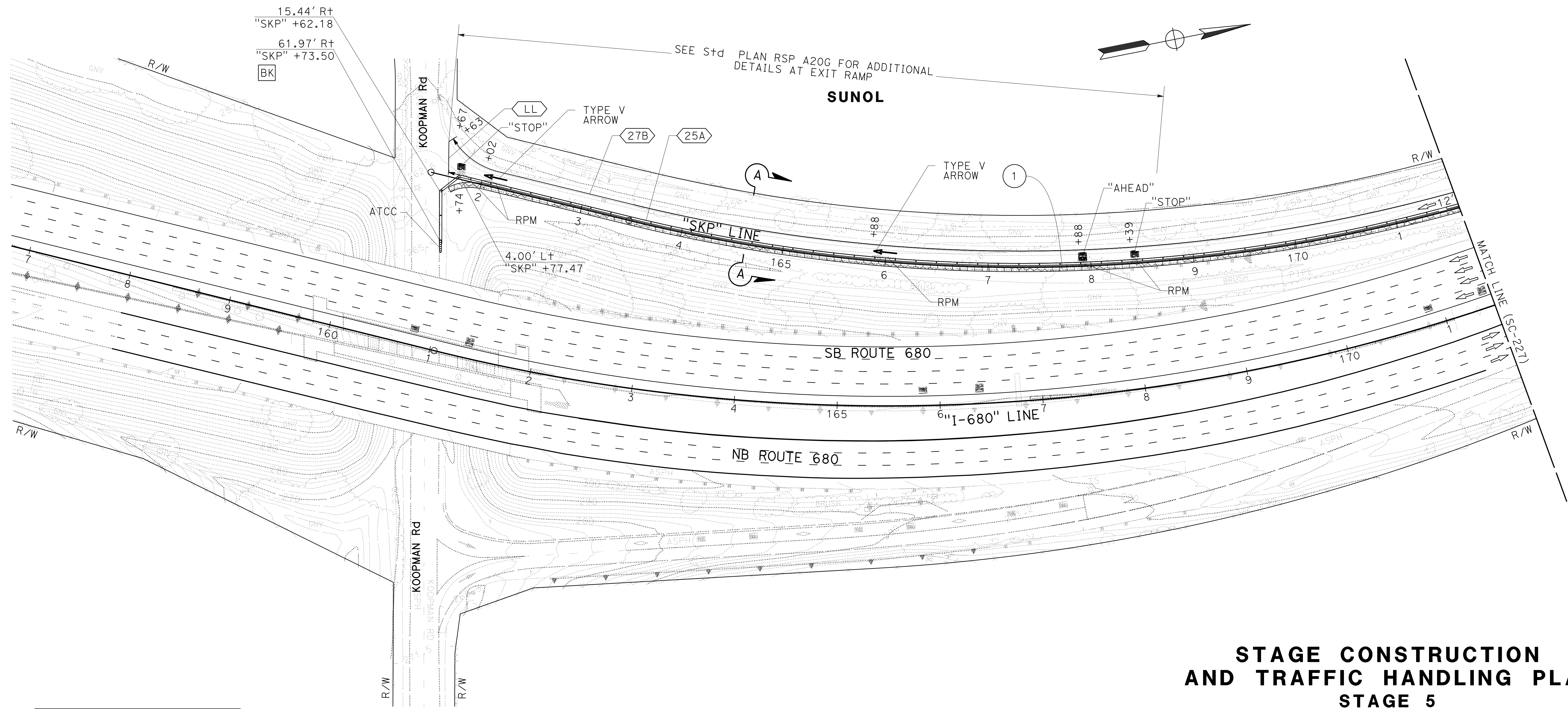

FOR NOTES, ABBREVIATIONS AND LEGEND, SEE SHEET SC-1

APPROVED FOR STAGE CONSTRUCTION AND TRAFFIC HANDLING WORK ONLY

**STAGE CONSTRUCTION AND TRAFFIC HANDLING PLAN
STAGE 5**

SCALE: 1" = 50'

SC-226

DESIGNED BY	JV	DATE	9-29-21
REVISOR	JV	DATE	9-29-21
CHECKED BY	ERIN McPHERSON		
DESIGNED BY	JAMIE VALDIVIA		
REVISOR	ERIN McPHERSON		
CHECKED BY	ERIN McPHERSON		
DESIGNED BY	TIMOTHY J. LEE		
REVISOR	TIMOTHY J. LEE		
CHECKED BY	TIMOTHY J. LEE		

Dist	COUNTY	ROUTE	POST MILES TOTAL PROJECT	SHEET No.	TOTAL SHEETS
04	Ala, CC	680	R11.0/R21.9, R0.0/R0.9	740	1710
			9-29-21		
REGISTERED CIVIL ENGINEER			DATE		
October 8, 2021			PLANS APPROVAL DATE		
WMH CORPORATION 55 South Market St Suite 1200 San Jose, CA 95113			ALAMEDA CTC 1111 Broadway Suite 800 Oakland, CA 94607		

NOTE:
FOR ACCURATE RIGHT OF WAY DATA, CONTACT
RIGHT OF WAY ENGINEERING AT THE DISTRICT OFFICE.

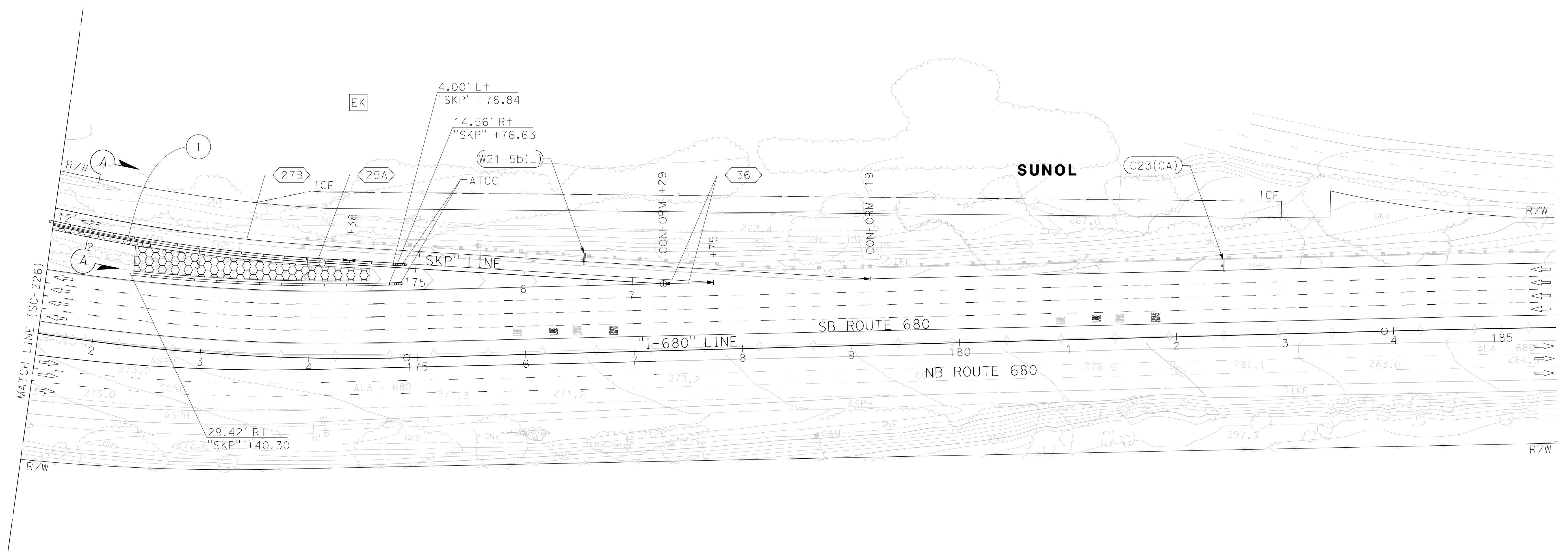
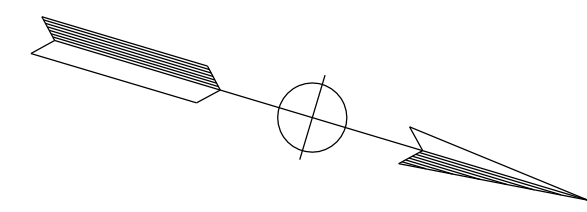

**STAGE CONSTRUCTION
AND TRAFFIC HANDLING PLAN
STAGE 5**

SCALE: 1" = 50'

SC-227

APPROVED FOR STAGE CONSTRUCTION AND TRAFFIC HANDLING WORK ONLY

FOR NOTES, ABBREVIATIONS AND
LEGEND, SEE SHEET SC-1 AND SC-226

CALCULATED-DESIGNED BY	JAMEY VALDIVIA
CHECKED BY	ERIN MCPHERSON
REVISOR	JV
DATE	9-29-21
FUNCTIONAL SUPERVISOR	TIMOTHY J. LEE
CONSULTANT	DEPARTMENT OF TRANSPORTATION
STATE OF CALIFORNIA	DEPARTMENT OF TRANSPORTATION

LAST REVISION DATE PLOTTED => 3/21/2022 09-29-21 TIME PLOTTED => 4:15:06 PM

Dist	COUNTY	ROUTE	POST MILES TOTAL PROJECT	SHEET No.	TOTAL SHEETS
04	Ala, CC	680	R11.0/R21.9, R0.0/R0.9	741	1710
			9-29-21		
REGISTERED CIVIL ENGINEER			DATE		
			October 8, 2021		
			PLANS APPROVAL DATE		
<small>THE STATE OF CALIFORNIA OR ITS OFFICERS OR AGENTS SHALL NOT BE RESPONSIBLE FOR THE ACCURACY OR COMPLETENESS OF SCANNED COPIES OF THIS PLAN SHEET.</small>					
WMH CORPORATION 55 South Market St Suite 1200 San Jose, CA 95113			ALAMEDA CTC 1111 Broadway Suite 800 Oakland, CA 94607		

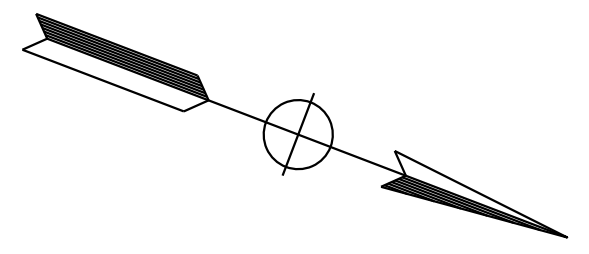

NOTE:
FOR ACCURATE RIGHT OF WAY DATA, CONTACT
RIGHT OF WAY ENGINEERING AT THE DISTRICT OFFICE.

		JV					
		9-29-21					
		REVISED BY					
		DATE REVISED					
	JAMEY VALDIVIA						
	ERIN McPHERSON						
	CALCULATED- DESIGNED BY						
	CHECKED BY						
	TIMOTHY J. LEE						
	CONSULTANT- FUNCTIONAL SUPERVISOR						
	DEPARTMENT OF TRANSPORTATION						
	STATE OF CALIFORNIA						

SUNOL

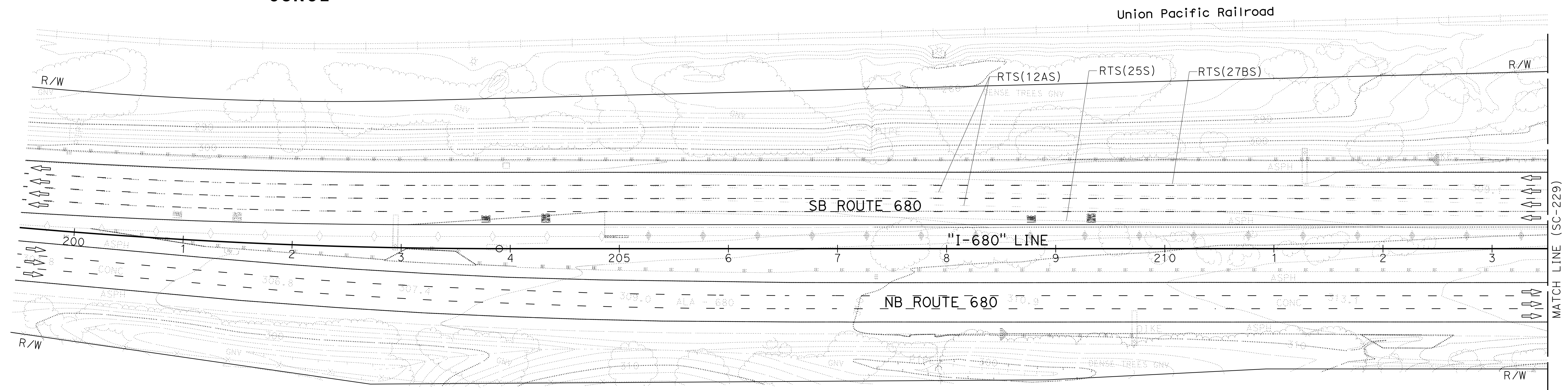

**STAGE CONSTRUCTION
AND TRAFFIC HANDLING PLAN
STAGE 5**

SCALE: 1" = 50'

SC-228

FOR NOTES, ABBREVIATIONS AND
LEGEND, SEE SHEET SC-1 AND SC-226

APPROVED FOR STAGE CONSTRUCTION AND TRAFFIC HANDLING WORK ONLY

O:\00300\DRAWING\FINAL_P5&E\0420000235ma228.dgn



LAST REVISION: DATE PLOTTED => 7-MAR-2022 09-29-21 TIME PLOTTED => 11:57

Dist	COUNTY	ROUTE	POST MILES TOTAL PROJECT	SHEET No.	TOTAL SHEETS
04	Ala, CC	680	R11.0/R21.9, RO.0/RO.9	742	1710
			9-29-21		
REGISTERED CIVIL ENGINEER			DATE		
October 8, 2021			PLANS APPROVAL DATE		
THE STATE OF CALIFORNIA OR ITS OFFICERS OR AGENTS SHALL NOT BE RESPONSIBLE FOR THE ACCURACY OR COMPLETENESS OF SCANNED COPIES OF THIS PLAN SHEET.					
WMH CORPORATION 55 South Market St Suite 1200 San Jose, CA 95113			ALAMEDA CTC 1111 Broadway Suite 800 Oakland, CA 94607		

NOTE:
FOR ACCURATE RIGHT OF WAY DATA, CONTACT RIGHT OF WAY ENGINEERING AT THE DISTRICT OFFICE.

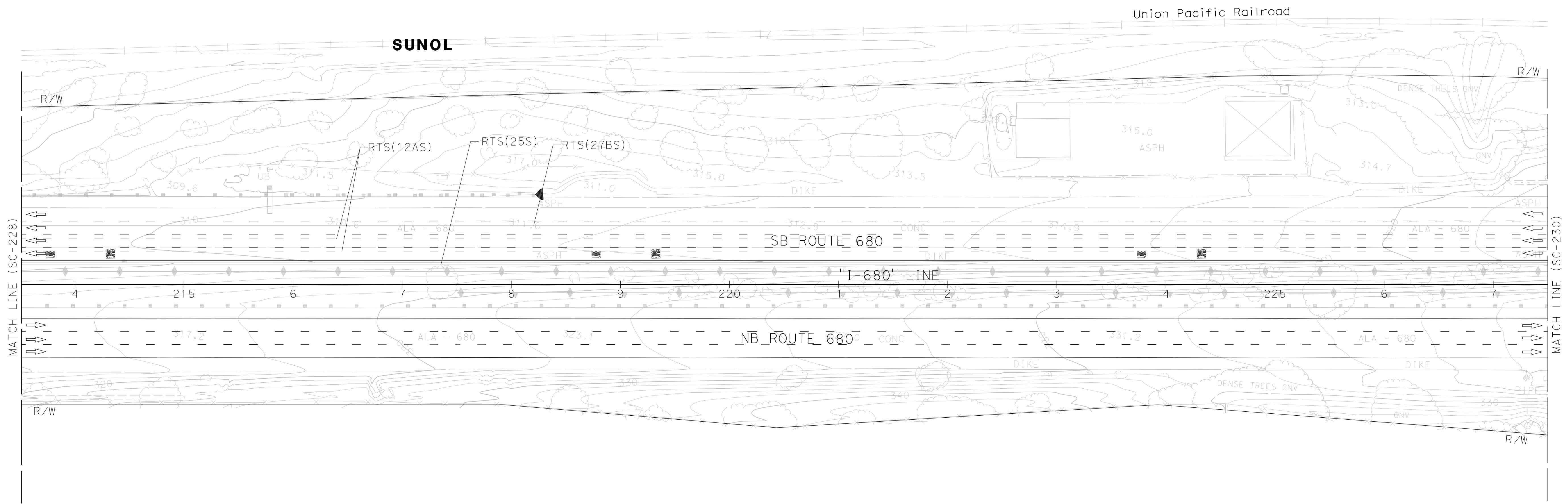
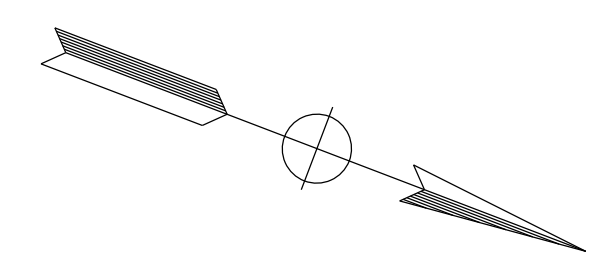

X:\680_SB_EXPRESS\000_CAD\Submittal\11\11\CADD_submittal\0420000235ma229.dgn
 STATE OF CALIFORNIA - DEPARTMENT OF TRANSPORTATION
 CONSULTANT FUNCTIONAL SUPERVISOR: TIMOTHY J. LEE
 CALCULATED/DESIGNED BY: JAMEY VALDIVIA
 CHECKED BY: ERIN MCPHERSON
 REVISED BY: J.V.
 DATE REVISED: 9-29-21

FOR NOTES, ABBREVIATIONS AND LEGEND, SEE SHEET SC-1 AND SC-226

APPROVED FOR STAGE CONSTRUCTION AND TRAFFIC HANDLING WORK ONLY

STAGE CONSTRUCTION AND TRAFFIC HANDLING PLAN STAGE 5

SCALE: 1" = 50'

SC-229

LAST REVISION: DATE PLOTTED => 3/21/2022
 09-29-21 TIME PLOTTED => 4:15:15 PM

Dist	COUNTY	ROUTE	POST MILES TOTAL PROJECT	SHEET No.	TOTAL SHEETS
04	Ala, CC	680	R11.0/R21.9, RO.0/RO.9	743	1710
REGISTERED CIVIL ENGINEER <i>Erin D. McPherson</i> DATE: 9-29-21			REGISTERED PROFESSIONAL ENGINEER ERIN D. McPHERSON No. C91111 Exp. 3-31-24 CIVIL STATE OF CALIFORNIA		
October 8, 2021 PLANS APPROVAL DATE					
<small>THE STATE OF CALIFORNIA OR ITS OFFICERS OR AGENTS SHALL NOT BE RESPONSIBLE FOR THE ACCURACY OR COMPLETENESS OF SCANNED COPIES OF THIS PLAN SHEET.</small>					
WMH CORPORATION 55 South Market St Suite 1200 San Jose, CA 95113			ALAMEDA CTC 1111 Broadway Suite 800 Oakland, CA 94607		

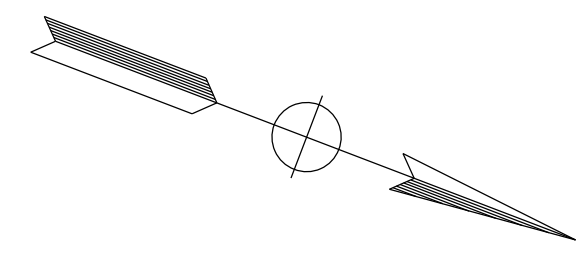

NOTE:
 FOR ACCURATE RIGHT OF WAY DATA, CONTACT
 RIGHT OF WAY ENGINEERING AT THE DISTRICT OFFICE.

X:\680_SB_EXPRESS\000_CAD\Submittal\11\1\CADD_submittal\0420000235ma230.dgn
 STATE OF CALIFORNIA - DEPARTMENT OF TRANSPORTATION
 CONSULTANT FUNCTIONAL SUPERVISOR: TIMOTHY J. LEE
 CALCULATED/DESIGNED BY: JAMEY VALDIVIA
 CHECKED BY: ERIN McPHERSON
 REVISED BY: JV
 DATE REVISED: 9-29-21

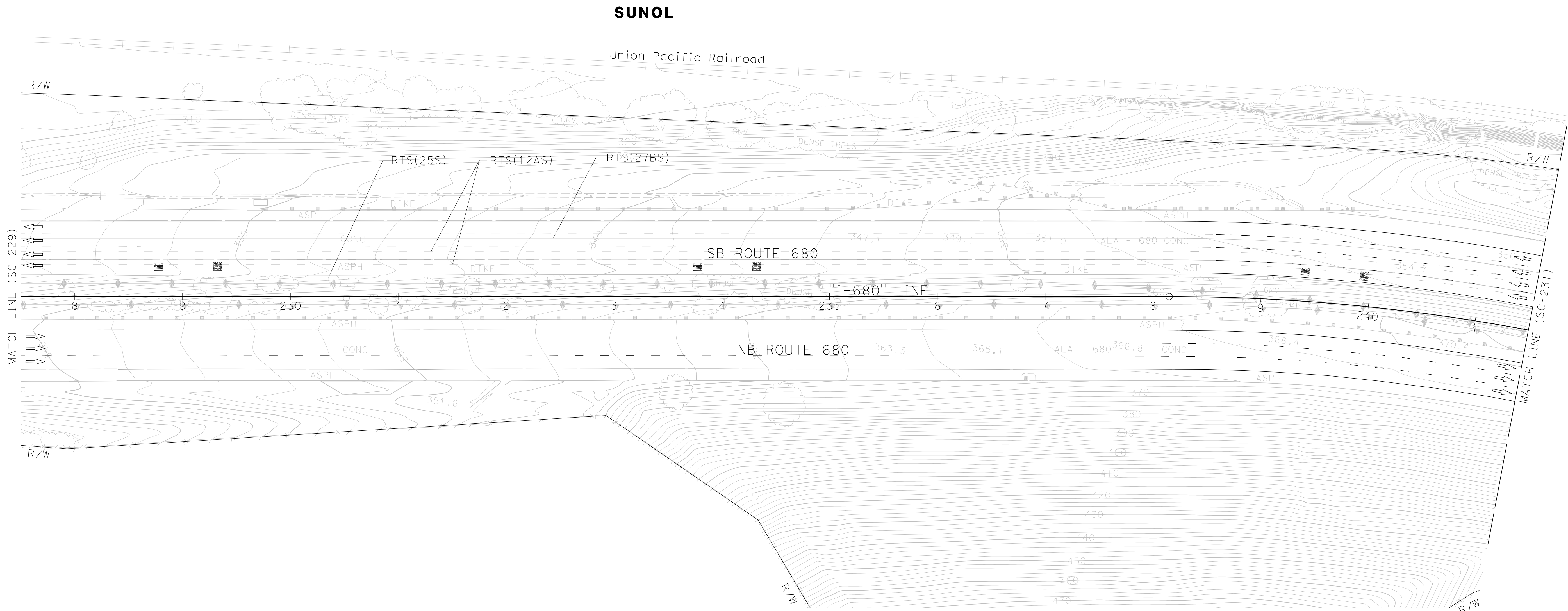

FOR NOTES, ABBREVIATIONS AND
 LEGEND, SEE SHEET SC-1 AND SC-226

STAGE CONSTRUCTION AND TRAFFIC HANDLING PLAN STAGE 5

SCALE: 1" = 50'

SC-230

APPROVED FOR STAGE CONSTRUCTION AND TRAFFIC HANDLING WORK ONLY

LAST REVISION: DATE PLOTTED => 3/21/2022
 09-29-21 TIME PLOTTED => 4:15:20 PM

Dist	COUNTY	ROUTE	POST MILES TOTAL PROJECT	SHEET No.	TOTAL SHEETS
04	Ala, CC	680	R11.0/R21.9, RO.0/RO.9	744	1710
			9-29-21		
REGISTERED CIVIL ENGINEER			DATE		
October 8, 2021			PLANS APPROVAL DATE		
WMH CORPORATION 55 South Market St Suite 1200 San Jose, CA 95113			ALAMEDA CTC 1111 Broadway Suite 800 Oakland, CA 94607		

NOTE:
FOR ACCURATE RIGHT OF WAY DATA, CONTACT
RIGHT OF WAY ENGINEERING AT THE DISTRICT OFFICE.

REVISOR	DATE	REVISION
JV	9-29-21	
REVISOR	DATE	REVISION
JAMEY VALDIVIA		
ERIN MCPHERSON		
CHECKED BY		
TIMOTHY J. LEE		
FUNCTIONAL SUPERVISOR		
CONSULTANT		
DEPARTMENT OF TRANSPORTATION		
STATE OF CALIFORNIA		

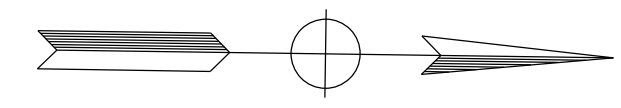

SUNOL

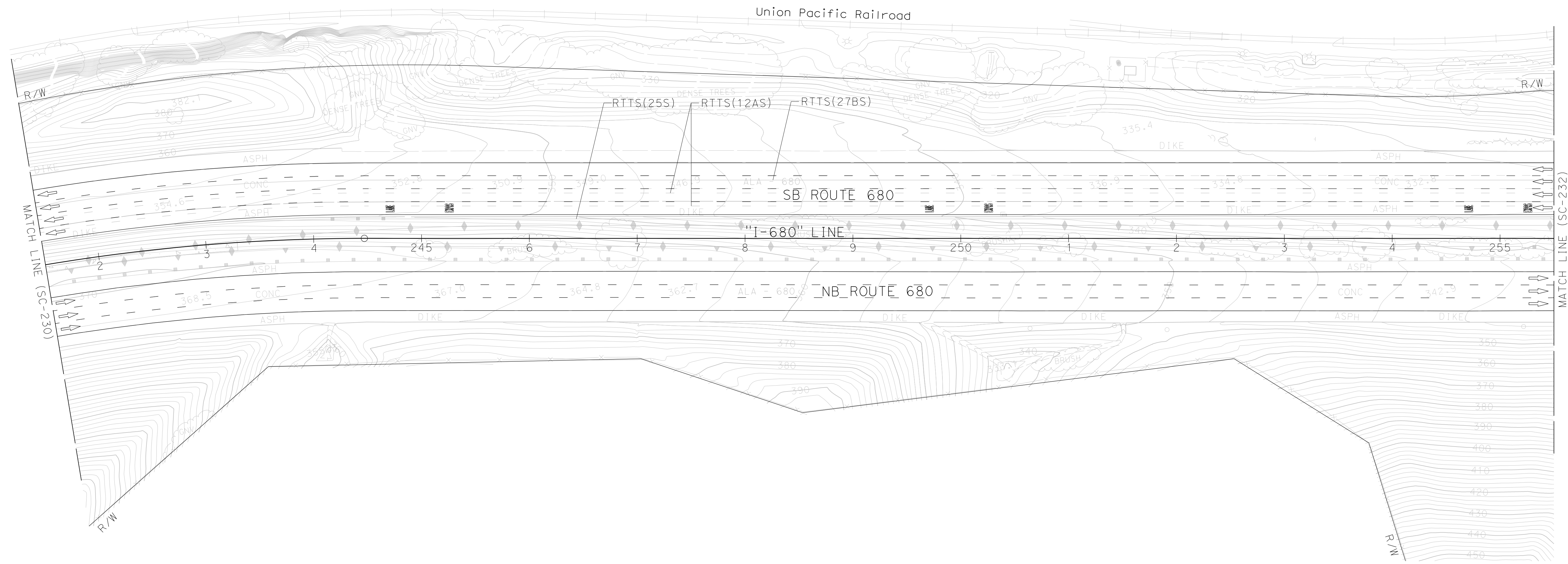

FOR NOTES, ABBREVIATIONS AND
LEGEND, SEE SHEET SC-1 AND SC-226

APPROVED FOR STAGE CONSTRUCTION AND TRAFFIC HANDLING WORK ONLY

**STAGE CONSTRUCTION
AND TRAFFIC HANDLING PLAN
STAGE 5**

SCALE: 1" = 50'

SC-231

LAST REVISION DATE PLOTTED => 3/21/2022 09-29-21 TIME PLOTTED => 4:15:26 PM

Dist	COUNTY	ROUTE	POST MILES TOTAL PROJECT	SHEET No.	TOTAL SHEETS
04	Ala, CC	680	R11.0/R21.9, RO.0/RO.9	745	1710
			9-29-21		
REGISTERED CIVIL ENGINEER			DATE		
October 8, 2021			PLANS APPROVAL DATE		
WMH CORPORATION 55 South Market St Suite 1200 San Jose, CA 95113			ALAMEDA CTC 1111 Broadway Suite 800 Oakland, CA 94607		

NOTE:
FOR ACCURATE RIGHT OF WAY DATA, CONTACT RIGHT OF WAY ENGINEERING AT THE DISTRICT OFFICE.

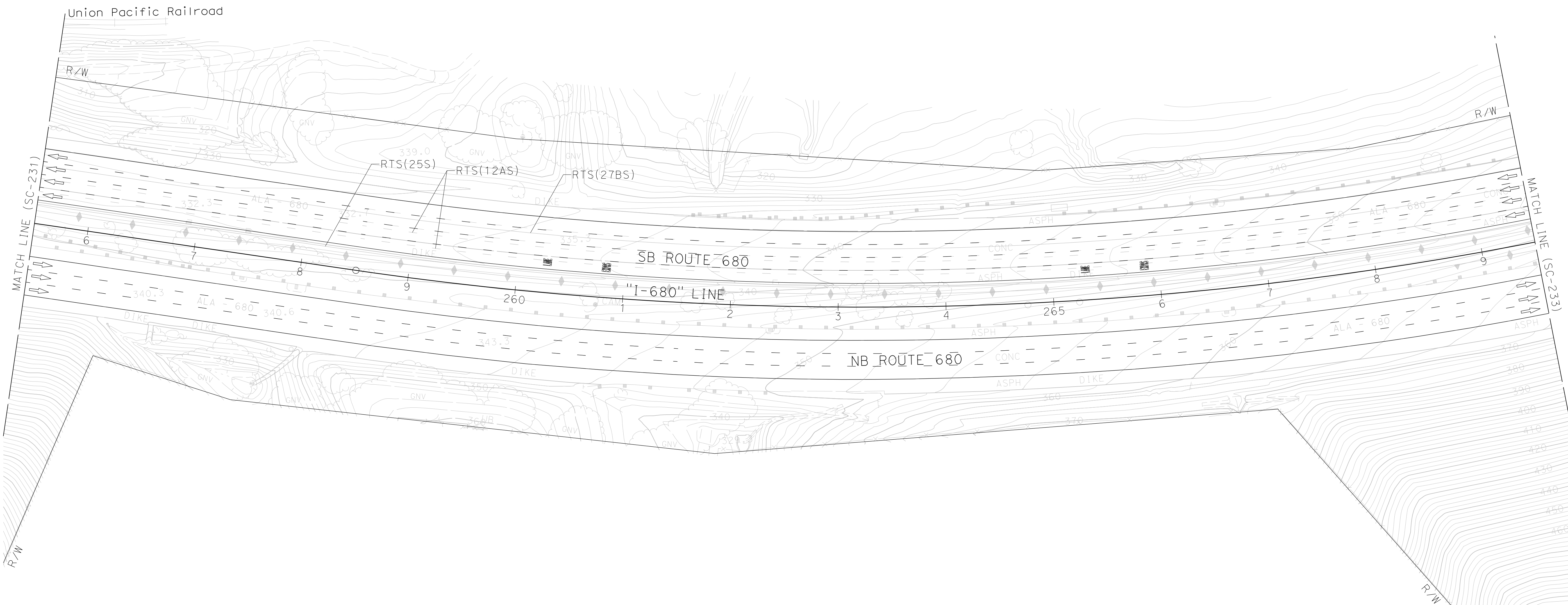
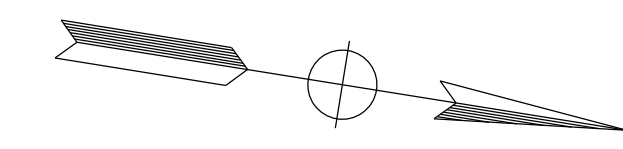

**STAGE CONSTRUCTION AND TRAFFIC HANDLING PLAN
STAGE 5**

SCALE: 1" = 50'

SC-232

APPROVED FOR STAGE CONSTRUCTION AND TRAFFIC HANDLING WORK ONLY

FOR NOTES, ABBREVIATIONS AND LEGEND, SEE SHEET SC-1 AND SC-226

STATE OF CALIFORNIA - DEPARTMENT OF TRANSPORTATION	CONSULTANT FUNCTIONAL SUPERVISOR	REVISOR	DATE
Ernst & Young	TIMOTHY J. LEE	JV	9-29-21
	CHECKED BY	REVISOR	DATE
	ERIN MCPHERSON		
	DESIGNED BY	REVISOR	DATE
	JAMEY VALDIVIA		

LAST REVISION DATE PLOTTED => 3/21/2022 09-29-21 TIME PLOTTED => 4:15:32 PM

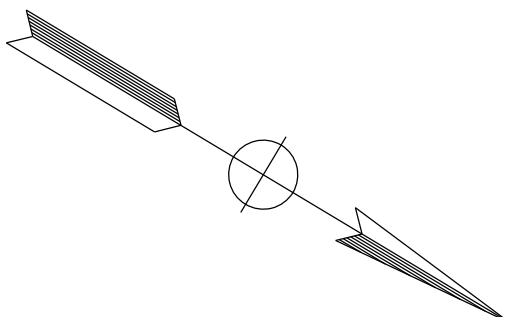

Dist	COUNTY	ROUTE	POST MILES TOTAL PROJECT	SHEET No.	TOTAL SHEETS
04	Ala, CC	680	R11.0/R21.9, RO.0/RO.9	746	1710
			9-29-21		
REGISTERED CIVIL ENGINEER			DATE		
			October 8, 2021		
			PLANS APPROVAL DATE		
<small>THE STATE OF CALIFORNIA OR ITS OFFICERS OR AGENTS SHALL NOT BE RESPONSIBLE FOR THE ACCURACY OR COMPLETENESS OF SCANNED COPIES OF THIS PLAN SHEET.</small>					
WMH CORPORATION 55 South Market St Suite 1200 San Jose, CA 95113			ALAMEDA CTC 1111 Broadway Suite 800 Oakland, CA 94607		

NOTE:
 FOR ACCURATE RIGHT OF WAY DATA, CONTACT RIGHT OF WAY ENGINEERING AT THE DISTRICT OFFICE.

CALCULATED/DESIGNED BY	JAMEY VALDIVIA
CHECKED BY	ERIN MCPHERSON
FUNCTIONAL SUPERVISOR	TIMOTHY J. LEE
CONSULTANT	DEPARTMENT OF TRANSPORTATION
STATE OF CALIFORNIA	DEPARTMENT OF TRANSPORTATION
DATE	9-29-21
REVISED BY	JV
DATE REVISED	9-29-21

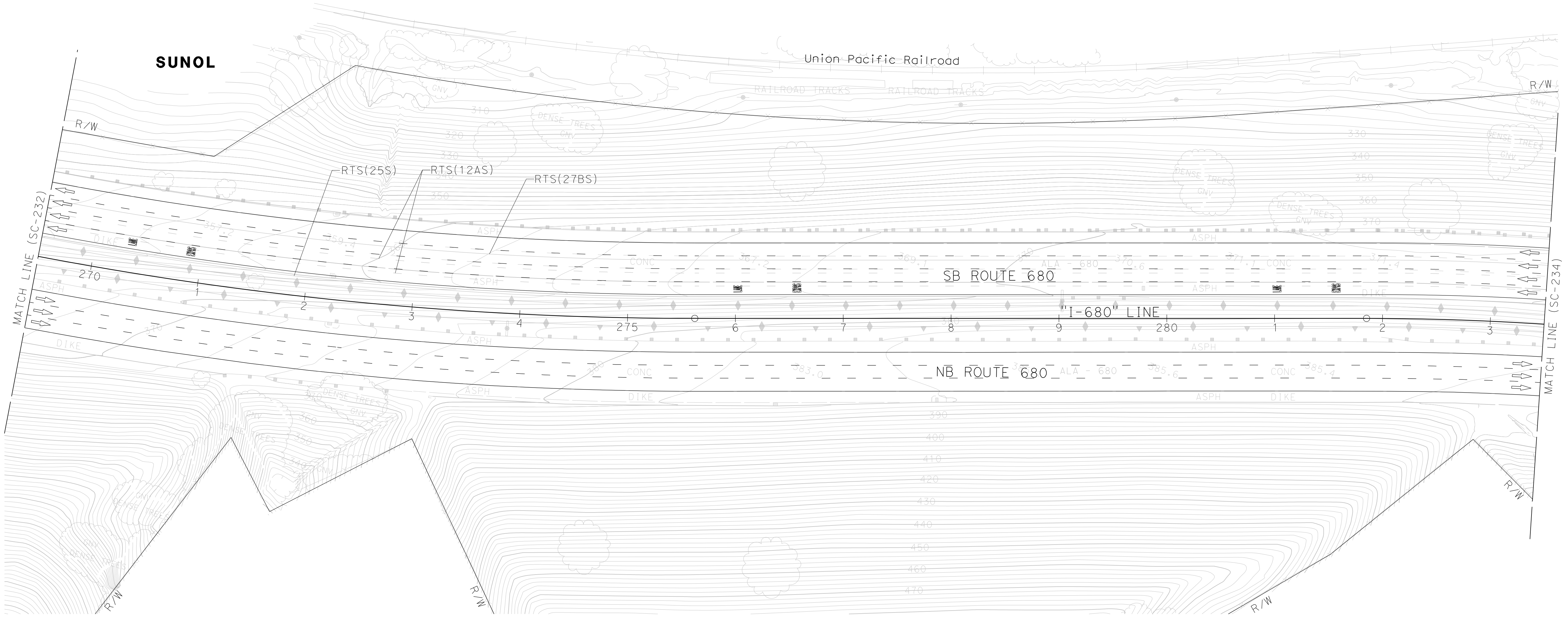

FOR NOTES, ABBREVIATIONS AND LEGEND, SEE SHEET SC-1 AND SC-226



STAGE CONSTRUCTION AND TRAFFIC HANDLING PLAN
STAGE 5

SCALE: 1" = 50'

APPROVED FOR STAGE CONSTRUCTION AND TRAFFIC HANDLING WORK ONLY

SC-233

LAST REVISION DATE PLOTTED => 3/21/2022 09-29-21 TIME PLOTTED => 4:15:36 PM

Dist	COUNTY	ROUTE	POST MILES TOTAL PROJECT	SHEET No.	TOTAL SHEETS
04	Ala, CC	680	R11.0/R21.9, RO.0/RO.9	747	1710
 REGISTERED CIVIL ENGINEER			9-29-21	DATE	
October 8, 2021 PLANS APPROVAL DATE					
WMH CORPORATION 55 South Market St Suite 1200 San Jose, CA 95113			ALAMEDA CTC 1111 Broadway Suite 800 Oakland, CA 94607		

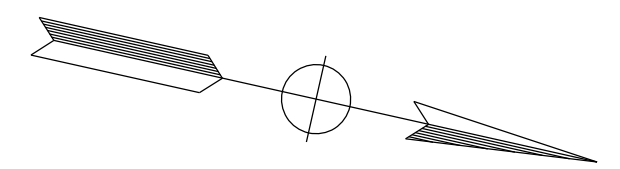

NOTE:
 FOR ACCURATE RIGHT OF WAY DATA, CONTACT
 RIGHT OF WAY ENGINEERING AT THE DISTRICT OFFICE.

STATE OF CALIFORNIA - DEPARTMENT OF TRANSPORTATION	CONSULTANT FUNCTIONAL SUPERVISOR	REVISOR	DATE
Ernst & Young	TIMOTHY J. LEE	JV	9-29-21
	CHECKED BY	REVISOR	DATE
	ERIN MCPHERSON	JV	9-29-21
	DESIGNED BY	REVISOR	DATE
	JAMEY VALDIVIA	JV	9-29-21

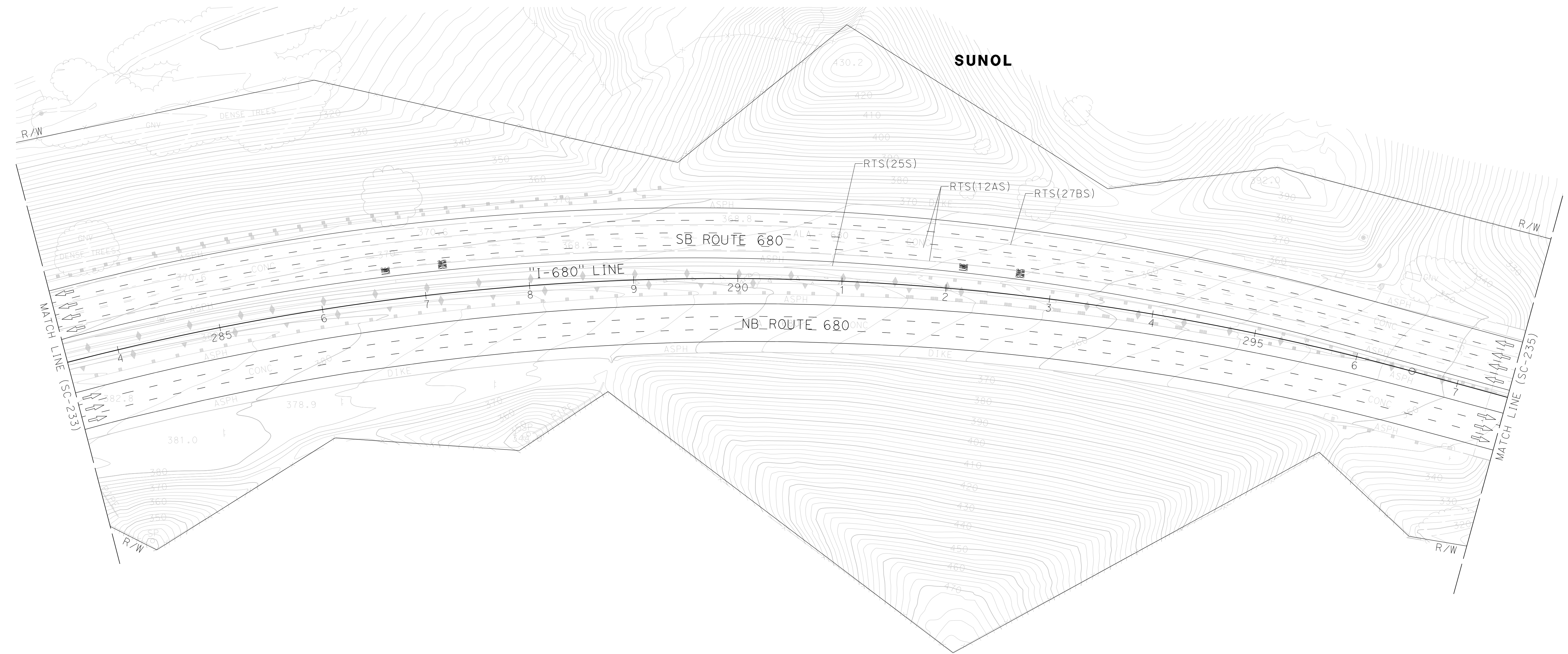

FOR NOTES, ABBREVIATIONS AND
 LEGEND, SEE SHEET SC-1 AND SC-226

APPROVED FOR STAGE CONSTRUCTION AND TRAFFIC HANDLING WORK ONLY

**STAGE CONSTRUCTION
 AND TRAFFIC HANDLING PLAN
 STAGE 5**

SCALE: 1" = 50'

SC-234

LAST REVISION DATE PLOTTED => 3/21/2022 09-29-21 TIME PLOTTED => 4:15:42 PM

Dist	COUNTY	ROUTE	POST MILES TOTAL PROJECT	SHEET No.	TOTAL SHEETS
04	Ala, CC	680	R11.0/R21.9, RO.0/RO.9	748	1710
			9-29-21		
ERIN D. McPHERSON			DATE		
			October 8, 2021		
			PLANS APPROVAL DATE		
<small>THE STATE OF CALIFORNIA OR ITS OFFICERS OR AGENTS SHALL NOT BE RESPONSIBLE FOR THE ACCURACY OR COMPLETENESS OF SCANNED COPIES OF THIS PLAN SHEET.</small>					
WMH CORPORATION 55 South Market St Suite 1200 San Jose, CA 95113			ALAMEDA CTC 1111 Broadway Suite 800 Oakland, CA 94607		

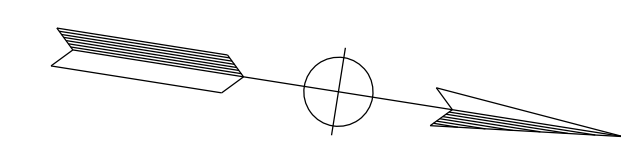
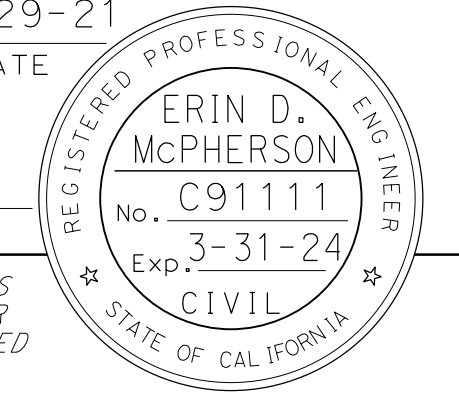

NOTE:
FOR ACCURATE RIGHT OF WAY DATA, CONTACT RIGHT OF WAY ENGINEERING AT THE DISTRICT OFFICE.

REVISIONED BY	DATE	REVISION
JV	9-29-21	
CALCULATED-DRAWN BY	CHECKED BY	DESIGNED BY
JAMEY VALDIVIA	ERIN McPHERSON	
CONSULTANT SUPERVISOR	FUNCTIONAL SUPERVISOR	
TIMOTHY J. LEE		
STATE OF CALIFORNIA	DEPARTMENT OF TRANSPORTATION	

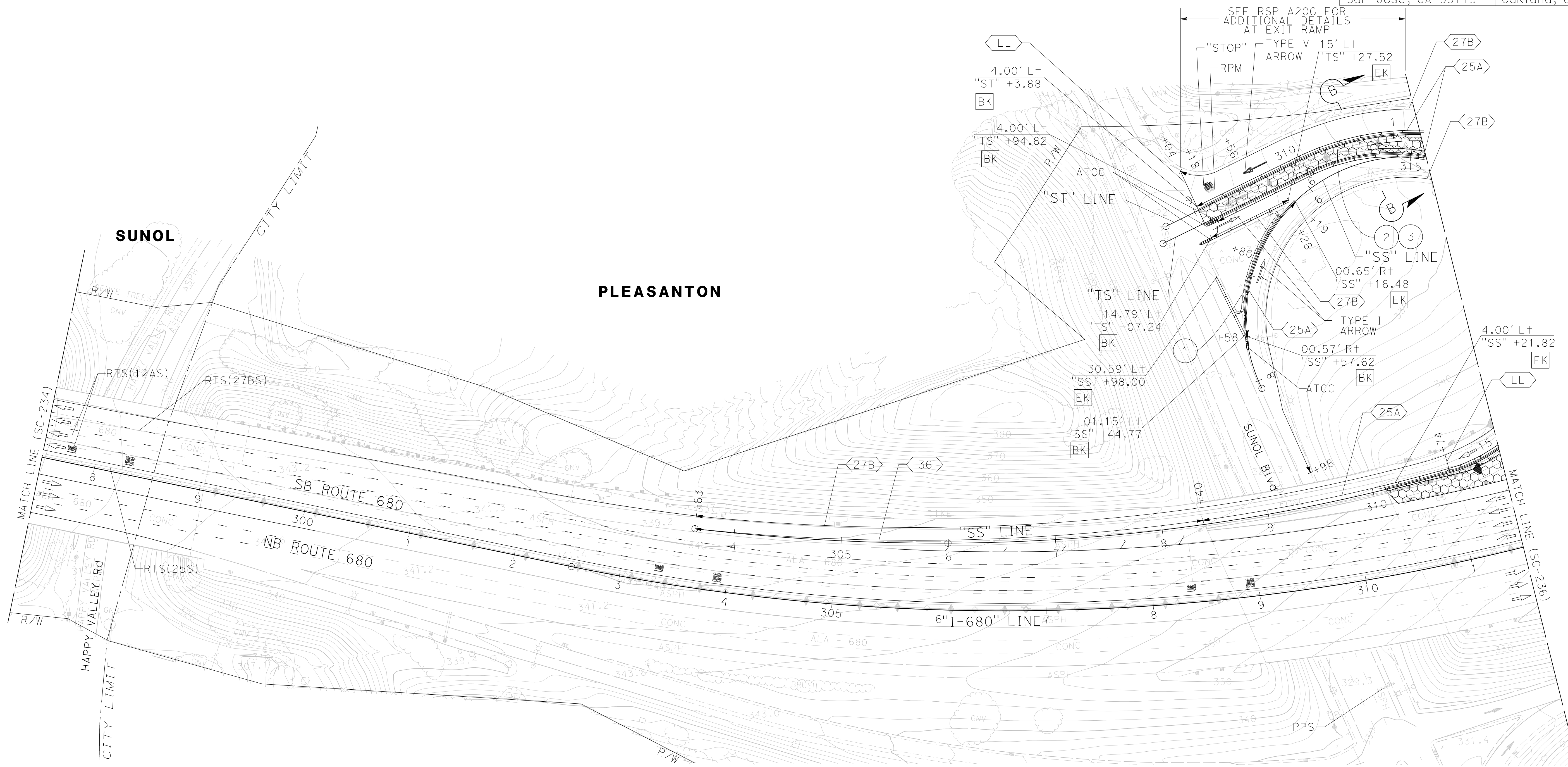

STAGE CONSTRUCTION AND TRAFFIC HANDLING PLAN STAGE 5

SCALE: 1" = 50'

SC-235

FOR NOTES, ABBREVIATIONS AND LEGEND, SEE SHEET SC-1 AND SC-226

APPROVED FOR STAGE CONSTRUCTION AND TRAFFIC HANDLING WORK ONLY

X:\680_SB_EXPRESS\000_CAD\Submittal\11\11\11\CADD_submittal\0420000235ma236.dgn
 STATE OF CALIFORNIA - DEPARTMENT OF TRANSPORTATION
Caltrans
 CONSULTANT FUNCTIONAL SUPERVISOR: TIMOTHY J. LEE
 CALCULATED/DESIGNED BY: JAMEY VALDIVIA
 CHECKED BY: ERIN McPHERSON
 REVISED BY: J.V.
 DATE REVISED: 09-29-21

NOTE:
 FOR ACCURATE RIGHT OF WAY DATA, CONTACT
 RIGHT OF WAY ENGINEERING AT THE DISTRICT OFFICE.

Dist	COUNTY	ROUTE	POST MILES TOTAL PROJECT	SHEET No.	TOTAL SHEETS
04	Ala, CC	680	R11.0/R21.9, RO.0/RO.9	749	1710

ERIN D. McPHERSON
 REGISTERED CIVIL ENGINEER
 DATE: 9-29-21
 October 8, 2021
 PLANS APPROVAL DATE

ERIN D. McPHERSON
 No. C91111
 Exp. 3-31-24
 CIVIL
 STATE OF CALIFORNIA

THE STATE OF CALIFORNIA OR ITS OFFICERS OR AGENTS SHALL NOT BE RESPONSIBLE FOR THE ACCURACY OR COMPLETENESS OF SCANNED COPIES OF THIS PLAN SHEET.

WMH CORPORATION
 55 South Market St
 Suite 1200
 San Jose, CA 95113

ALAMEDA CTC
 1111 Broadway
 Suite 800
 Oakland, CA 94607

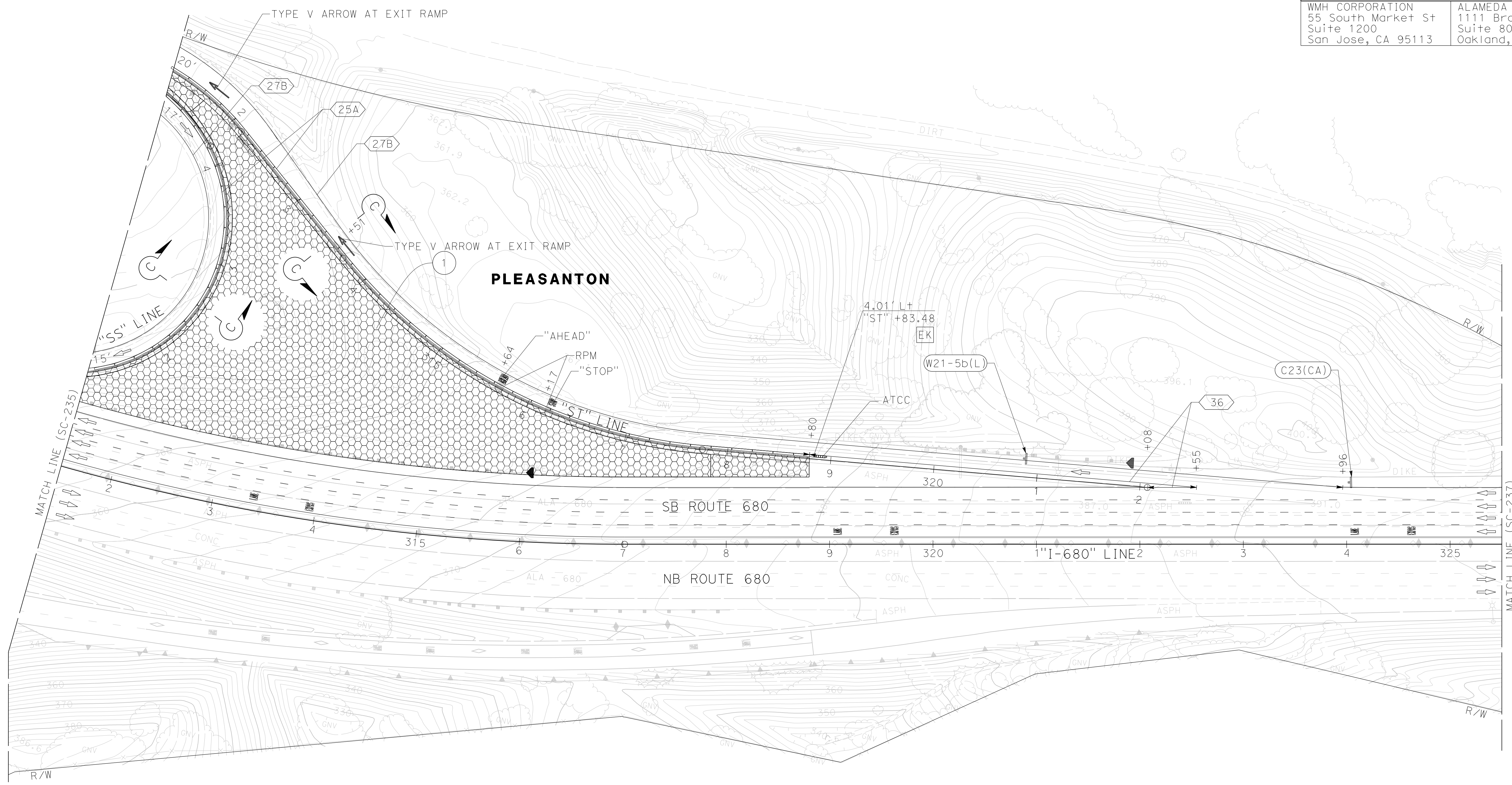
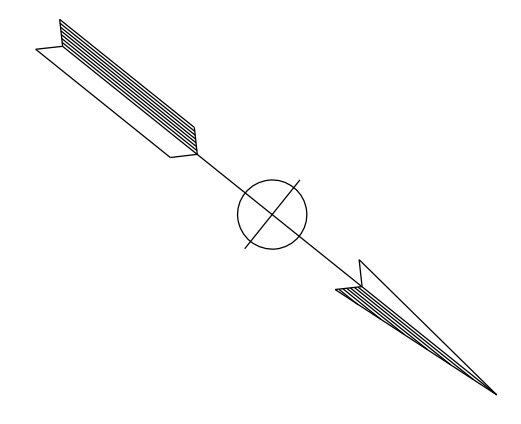

FOR NOTES, ABBREVIATIONS AND LEGEND, SEE SHEET SC-1 AND SC-226

APPROVED FOR STAGE CONSTRUCTION AND TRAFFIC HANDLING WORK ONLY

STAGE CONSTRUCTION AND TRAFFIC HANDLING PLAN STAGE 5

SCALE: 1" = 50'

SC-236

LAST REVISION: 09-29-21
 DATE PLOTTED => 3/21/2022
 TIME PLOTTED => 4:15:52 PM

0:\00300\DRAWING\FINAL_P58E\0420000235ma237.dgn
 STATE OF CALIFORNIA - DEPARTMENT OF TRANSPORTATION
 Et Caltrans®
 USERNAME => p302438
 DGN FILE => 0420000235ma237.dgn

NOTE:
 FOR ACCURATE RIGHT OF WAY DATA, CONTACT
 RIGHT OF WAY ENGINEERING AT THE DISTRICT OFFICE.

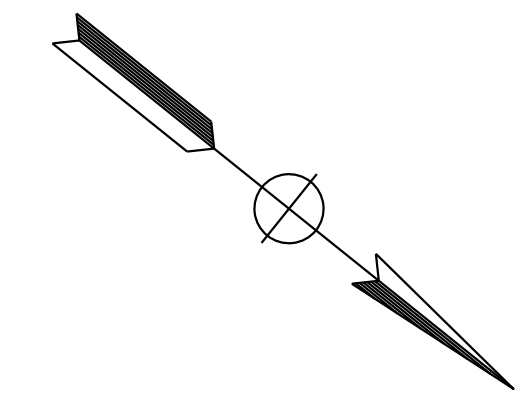

Dist	COUNTY	ROUTE	POST MILES TOTAL PROJECT	SHEET No.	TOTAL SHEETS
04	Ala, CC	680	R11.0/R21.9, R0.0/R0.9	750	1710
			9-29-21		
REGISTERED CIVIL ENGINEER			DATE		
			October 8, 2021		
			PLANS APPROVAL DATE		
<small>THE STATE OF CALIFORNIA OR ITS OFFICERS OR AGENTS SHALL NOT BE RESPONSIBLE FOR THE ACCURACY OR COMPLETENESS OF SCANNED COPIES OF THIS PLAN SHEET.</small>					
WMH CORPORATION 55 South Market St Suite 1200 San Jose, CA 95113			ALAMEDA CTC 1111 Broadway Suite 800 Oakland, CA 94607		

REVISOR	DATE	REVISION
JV	9-29-21	
JAMEY VALDIVIA		
ERIN MCPHERSON		
CALCULATED-DESIGNED BY	CHECKED BY	
TIMOTHY J. LEE		
CONSULTANT	FUNCTIONAL SUPERVISOR	

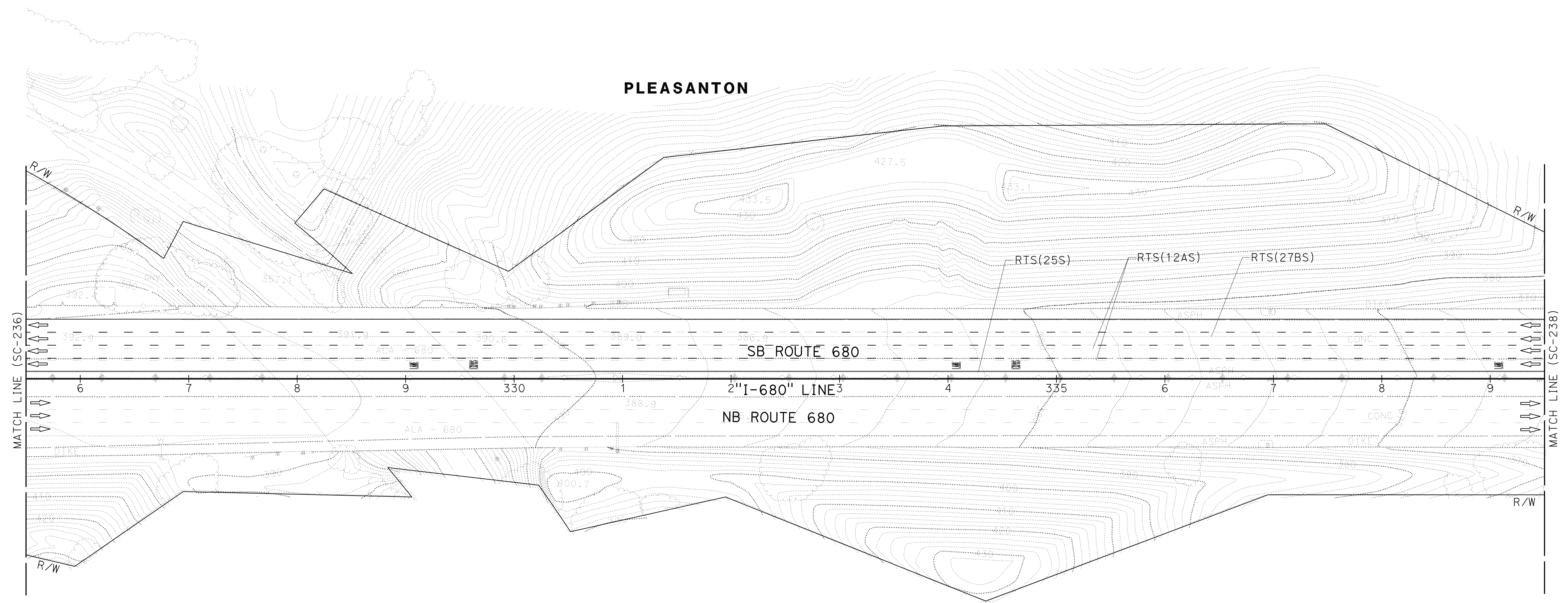

FOR NOTES, ABBREVIATIONS AND
 LEGEND, SEE SHEET SC-1 AND SC-226

APPROVED FOR STAGE CONSTRUCTION AND TRAFFIC HANDLING WORK ONLY

**STAGE CONSTRUCTION
 AND TRAFFIC HANDLING PLAN
 STAGE 5**

SCALE: 1" = 50'

SC-237

LAST REVISION: 09-29-21 11:58
 DATE PLOTTED => 7-MAR-2022
 TIME PLOTTED => 11:58

X:\680_SB_EXPRESS\000_CAD\Submit\10420000235ma238.dgn
 STATE OF CALIFORNIA - DEPARTMENT OF TRANSPORTATION
 CONSULTANT FUNCTIONAL SUPERVISOR
 JAMEY VALDIVIA
 ERIN McPHERSON
 CHECKED BY
 TIMOTHY J. LEE
 REVISIONS
 REVISED BY
 DATE REVISED
 JV
 9-29-21

NOTE:
 FOR ACCURATE RIGHT OF WAY DATA, CONTACT
 RIGHT OF WAY ENGINEERING AT THE DISTRICT OFFICE.

Dist	COUNTY	ROUTE	POST MILES TOTAL PROJECT	SHEET No.	TOTAL SHEETS
04	Ala, CC	680	R11.0/R21.9, R0.0/R0.9	751	1710

ERIN D. McPHERSON
 REGISTERED CIVIL ENGINEER
 No. C91111
 Exp. 3-31-24
 CIVIL
 STATE OF CALIFORNIA

9-29-21
 DATE
 October 8, 2021
 PLANS APPROVAL DATE

THE STATE OF CALIFORNIA OR ITS OFFICERS
 OR AGENTS SHALL NOT BE RESPONSIBLE FOR
 THE ACCURACY OR COMPLETENESS OF SCANNED
 COPIES OF THIS PLAN SHEET.

WMH CORPORATION 55 South Market St Suite 1200 San Jose, CA 95113	ALAMEDA CTC 1111 Broadway Suite 800 Oakland, CA 94607
---	--

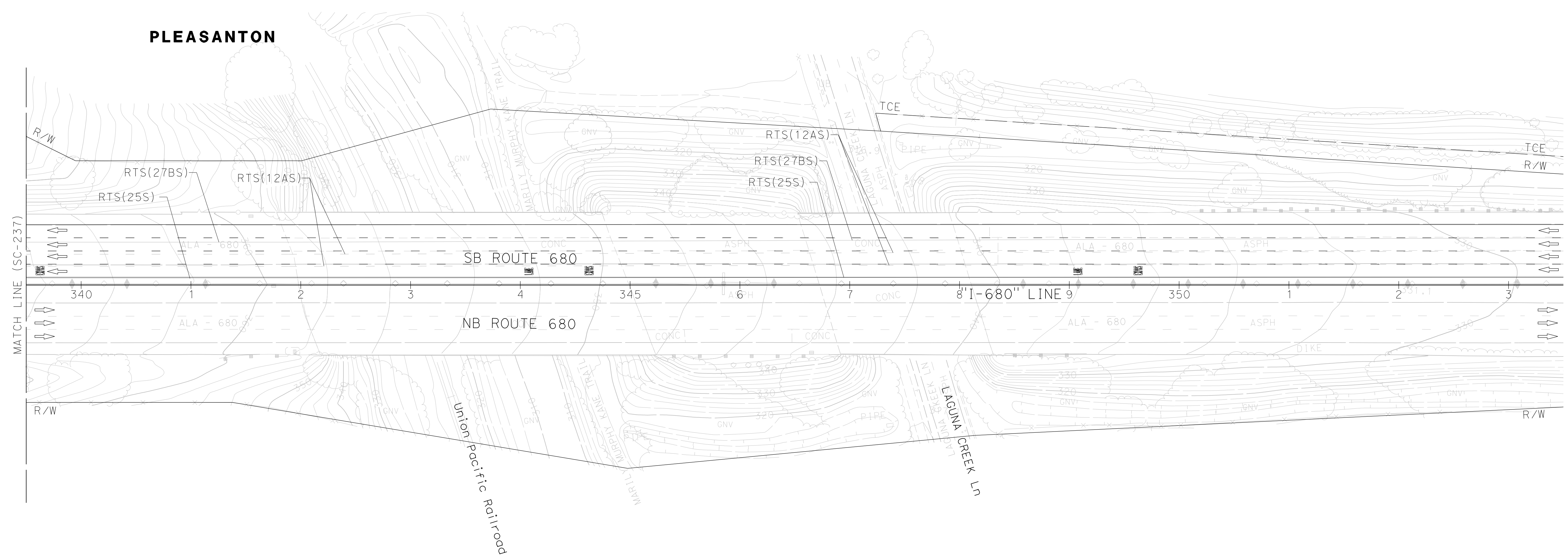
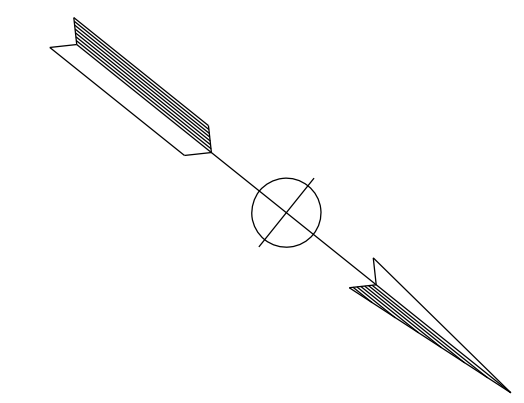

FOR NOTES, ABBREVIATIONS AND
 LEGEND, SEE SHEET SC-1 AND SC-226

APPROVED FOR STAGE CONSTRUCTION AND TRAFFIC HANDLING WORK ONLY

**STAGE CONSTRUCTION
 AND TRAFFIC HANDLING PLAN
 STAGE 5**

SCALE: 1" = 50'

SC-238

LAST REVISION
 DATE PLOTTED => 3/21/2022
 09-29-21
 TIME PLOTTED => 4:16:04 PM

Dist	COUNTY	ROUTE	POST MILES TOTAL PROJECT	SHEET No.	TOTAL SHEETS
04	Ala, CC	680	R11.0/R21.9, RO.0/RO.9	752	1710
			9-29-21		
REGISTERED CIVIL ENGINEER			DATE		
October 8, 2021			PLANS APPROVAL DATE		
<small>THE STATE OF CALIFORNIA OR ITS OFFICERS OR AGENTS SHALL NOT BE RESPONSIBLE FOR THE ACCURACY OR COMPLETENESS OF SCANNED COPIES OF THIS PLAN SHEET.</small>					
WMH CORPORATION 55 South Market St Suite 1200 San Jose, CA 95113			ALAMEDA CTC 1111 Broadway Suite 800 Oakland, CA 94607		

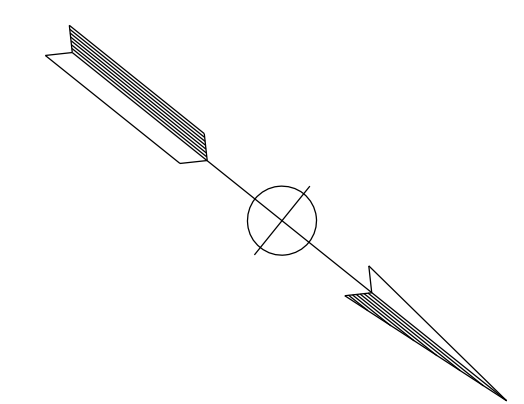
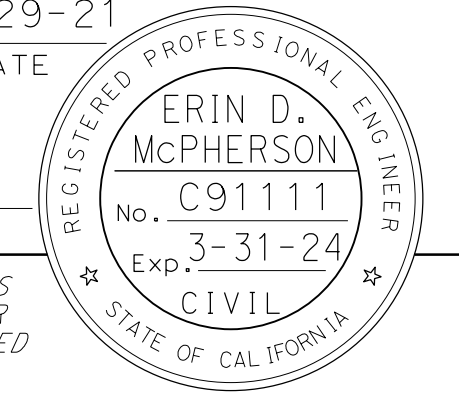

NOTE:
FOR ACCURATE RIGHT OF WAY DATA, CONTACT RIGHT OF WAY ENGINEERING AT THE DISTRICT OFFICE.

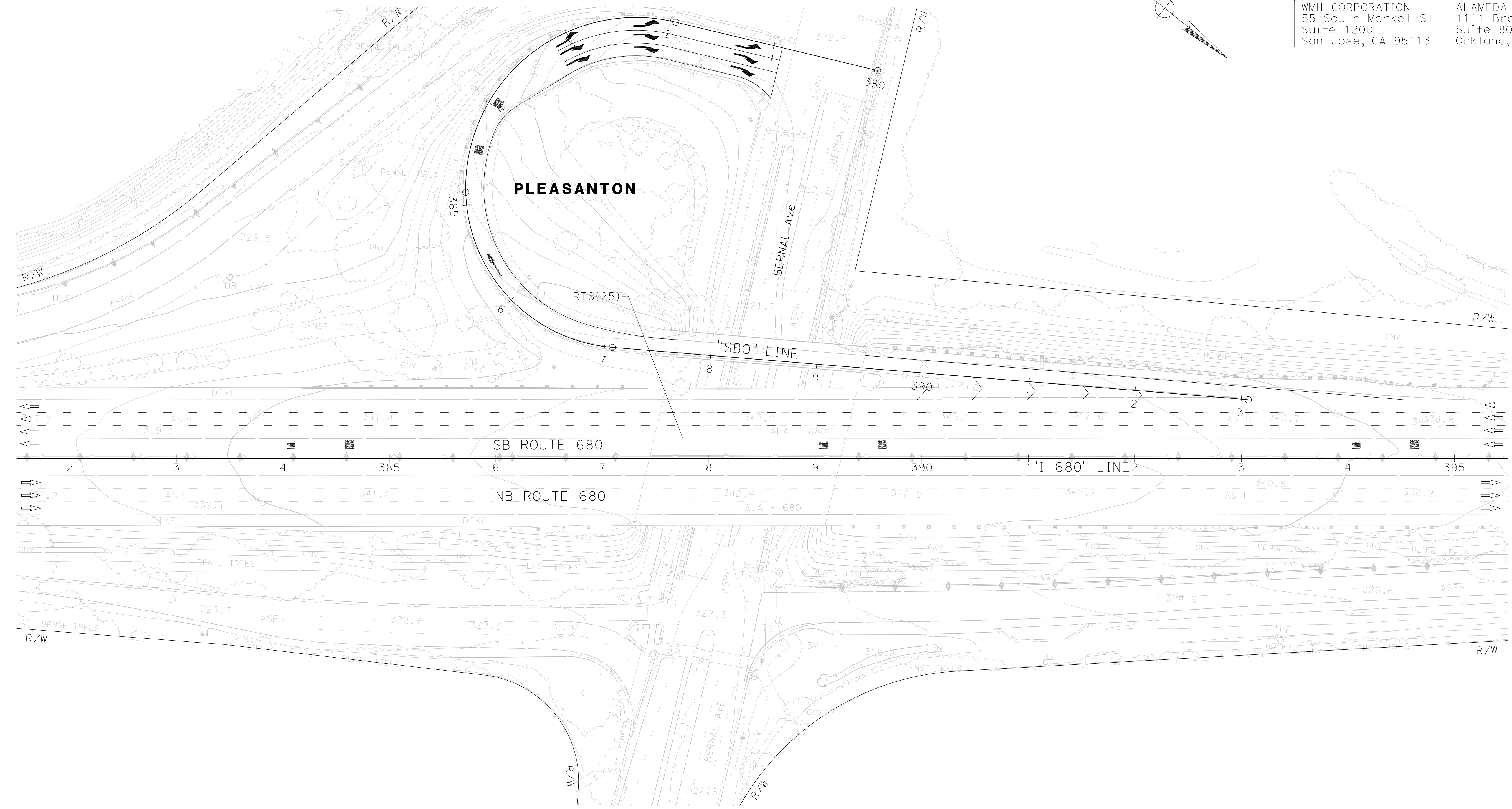

CALCULATED-DESIGNED BY	JAMEY VALDIVIA
CHECKED BY	ERIN MCPHERSON
REVISOR	JV
DATE	9-29-21
FUNCTIONAL SUPERVISOR	TIMOTHY J. LEE
CONSULTANT	DEPARTMENT OF TRANSPORTATION
STATE OF CALIFORNIA	DEPARTMENT OF TRANSPORTATION

FOR NOTES, ABBREVIATIONS AND LEGEND, SEE SHEET SC-1 AND SC-226

APPROVED FOR STAGE CONSTRUCTION AND TRAFFIC HANDLING WORK ONLY

STAGE CONSTRUCTION AND TRAFFIC HANDLING PLAN STAGE 5

SCALE: 1" = 50'

SC-239

LAST REVISION: 09-29-21 DATE PLOTTED => 3/21/2022 TIME PLOTTED => 4:16:09 PM

Dist	COUNTY	ROUTE	POST MILES TOTAL PROJECT	SHEET No.	TOTAL SHEETS
04	Ala, CC	680	R11.0/R21.9, R0.0/R0.9	753	1710
			9-29-21		
REGISTERED CIVIL ENGINEER			DATE		
			October 8, 2021		
			PLANS APPROVAL DATE		
<small>THE STATE OF CALIFORNIA OR ITS OFFICERS OR AGENTS SHALL NOT BE RESPONSIBLE FOR THE ACCURACY OR COMPLETENESS OF SCANNED COPIES OF THIS PLAN SHEET.</small>					
WMH CORPORATION 55 South Market St Suite 1200 San Jose, CA 95113			ALAMEDA CTC 1111 Broadway Suite 800 Oakland, CA 94607		

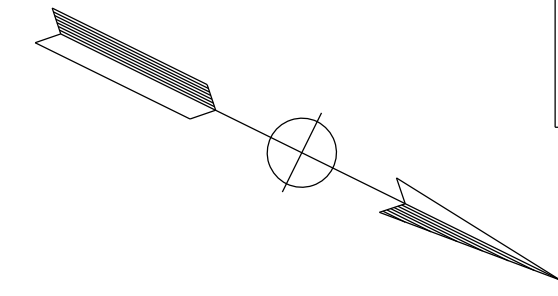
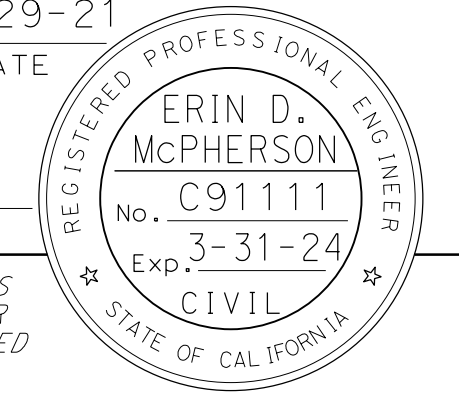

NOTE:
FOR ACCURATE RIGHT OF WAY DATA, CONTACT
RIGHT OF WAY ENGINEERING AT THE DISTRICT OFFICE.

DESIGNED BY	JAMEY VALDIVIA
CHECKED BY	ERIN MCPHERSON
FUNCTIONAL SUPERVISOR	TIMOTHY J. LEE
CONSULTANT	DEPARTMENT OF TRANSPORTATION
STATE OF CALIFORNIA	DEPARTMENT OF TRANSPORTATION

PLEASANTON

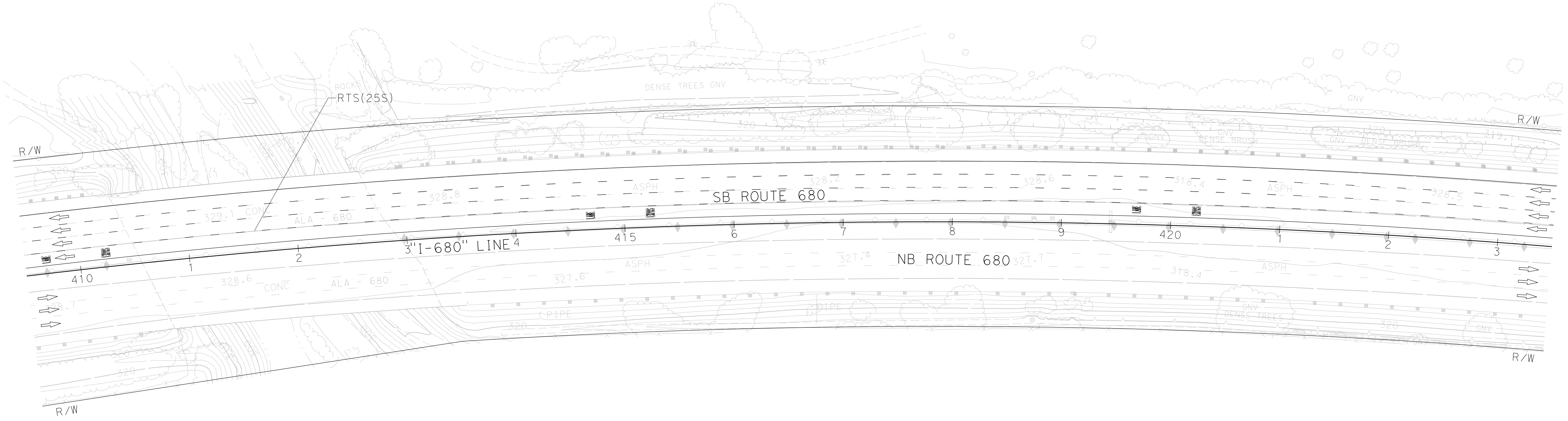

FOR NOTES, ABBREVIATIONS AND
LEGEND, SEE SHEET SC-1 AND SC-226

**STAGE CONSTRUCTION
AND TRAFFIC HANDLING PLAN
STAGE 5**

SCALE: 1" = 50'

SC-240

APPROVED FOR STAGE CONSTRUCTION AND TRAFFIC HANDLING WORK ONLY

LAST REVISION DATE PLOTTED => 3/21/2022 09-29-21 TIME PLOTTED => 4:16:14 PM

Dist	COUNTY	ROUTE	POST MILES TOTAL PROJECT	SHEET No.	TOTAL SHEETS
04	Ala, CC	680	R11.0/R21.9, RO.0/RO.9	754	1710
			9-29-21	DATE	
ERIN D. McPHERSON			REGISTERED CIVIL ENGINEER		
			October 8, 2021		
			PLANS APPROVAL DATE		
THE STATE OF CALIFORNIA OR ITS OFFICERS OR AGENTS SHALL NOT BE RESPONSIBLE FOR THE ACCURACY OR COMPLETENESS OF SCANNED COPIES OF THIS PLAN SHEET.					
WMH CORPORATION 55 South Market St Suite 1200 San Jose, CA 95113			ALAMEDA CTC 1111 Broadway Suite 800 Oakland, CA 94607		

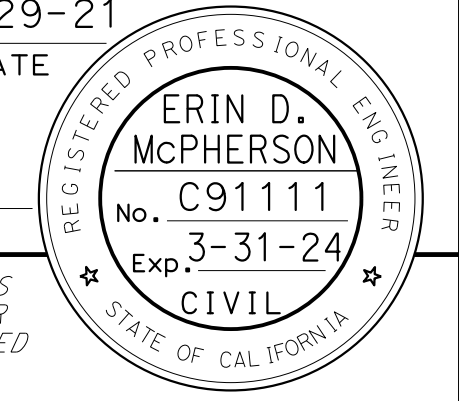

NOTE:
FOR ACCURATE RIGHT OF WAY DATA, CONTACT RIGHT OF WAY ENGINEERING AT THE DISTRICT OFFICE.

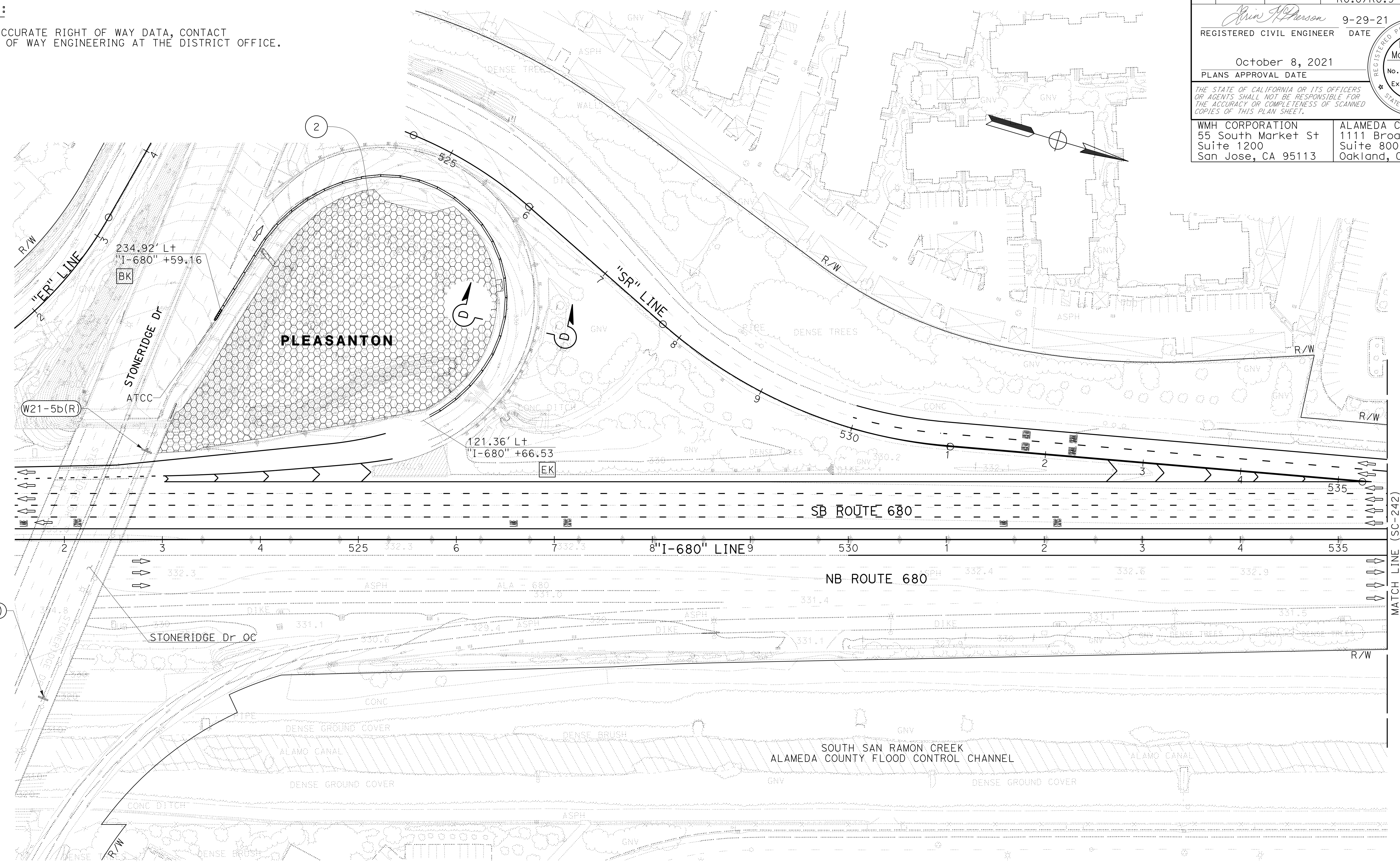

**STAGE CONSTRUCTION
AND TRAFFIC HANDLING PLAN
STAGE 5**

SCALE: 1" = 50'

SC-241

APPROVED FOR STAGE CONSTRUCTION AND TRAFFIC HANDLING WORK ONLY

FOR NOTES, ABBREVIATIONS AND LEGEND, SEE SHEET SC-1 AND SC-226

STATE OF CALIFORNIA - DEPARTMENT OF TRANSPORTATION	CONSULTANT	FUNCTIONAL SUPERVISOR	CALCULATED-DESIGNED BY	REVISOR	DATE
Ernst & Young Global Limited	JAMEY VALDIVIA	TIMOTHY J. LEE	ERIN McPHERSON	JV	9-29-21

Dist	COUNTY	ROUTE	POST MILES TOTAL PROJECT	SHEET No.	TOTAL SHEETS
04	Ala, CC	680	R11.0/R21.9, RO.0/RO.9	755	1710
			9-29-21		
REGISTERED CIVIL ENGINEER			DATE		
October 8, 2021			PLANS APPROVAL DATE		
WMH CORPORATION 55 South Market St Suite 1200 San Jose, CA 95113			ALAMEDA CTC 1111 Broadway Suite 800 Oakland, CA 94607		

NOTE:
FOR ACCURATE RIGHT OF WAY DATA, CONTACT RIGHT OF WAY ENGINEERING AT THE DISTRICT OFFICE.

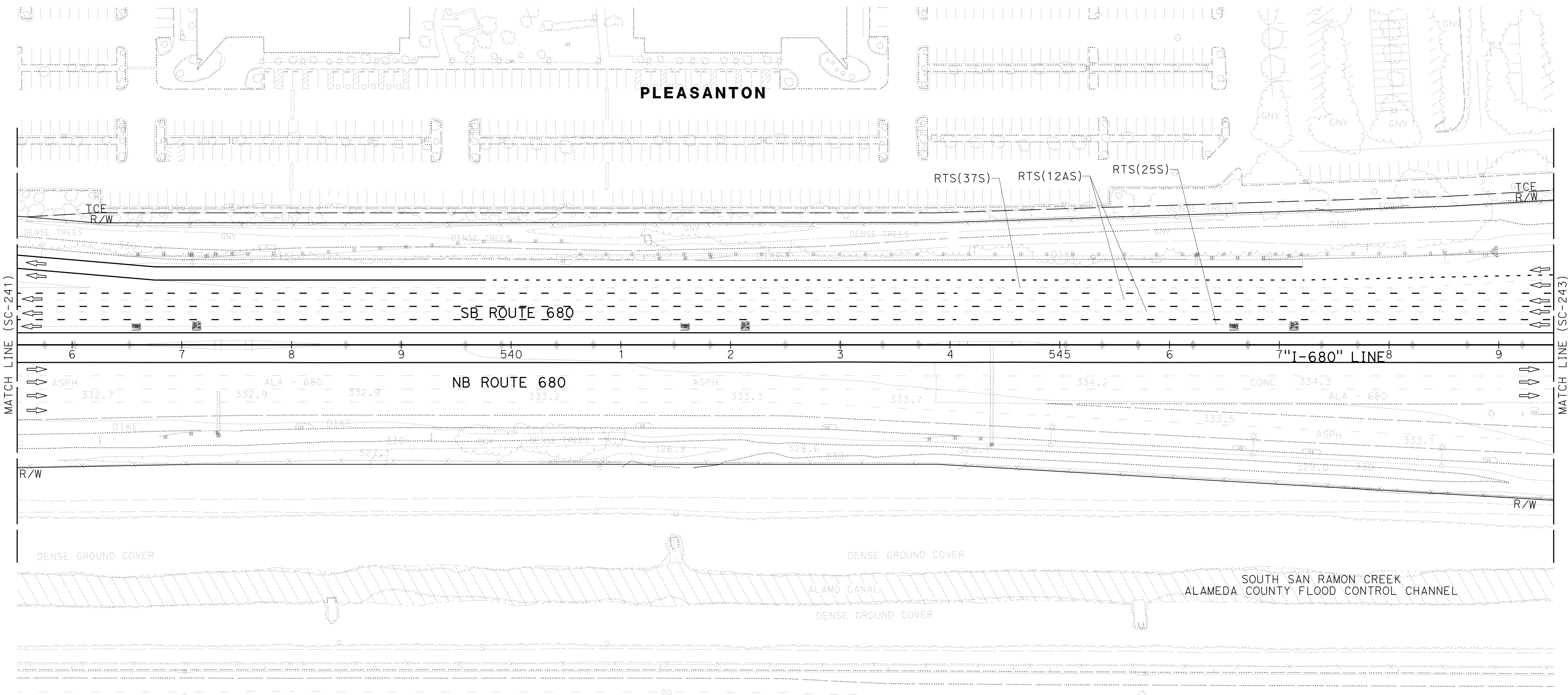
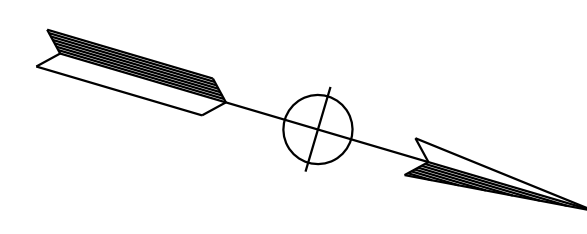

O:\0030\UDRAFT\TING\FINAL_P58E\0420000235m0242.dgn
 STATE OF CALIFORNIA - DEPARTMENT OF TRANSPORTATION
 Et Caltrans®
 CONSULTANT SUPERVISOR: JAMES VALDIVIA
 CONSULTANT: ERIN MCPHERSON
 CHECKED BY: JAMES VALDIVIA
 DESIGNED BY: ERIN MCPHERSON
 REVISIONS: JV 9-29-21
 SUPERVISOR: TIMOTHY J. LEE
 USERNAME => p302438
 DGN FILE => 0420000235m0242.dgn

FOR NOTES, ABBREVIATIONS AND LEGEND, SEE SHEET SC-1 AND SC-226

APPROVED FOR STAGE CONSTRUCTION AND TRAFFIC HANDLING WORK ONLY

STAGE CONSTRUCTION AND TRAFFIC HANDLING PLAN
STAGE 5

SCALE: 1" = 50'

SC-242

LAST REVISION: DATE PLOTTED => 7-MAR-2022
 09-29-21 TIME PLOTTED => 11:59

STATE OF CALIFORNIA	DEPARTMENT OF TRANSPORTATION	CONSULTANT	FUNCTIONAL SUPERVISOR	CALCULATED/DESIGNED BY	REVISOR	DATE
Er	Caltrans	TIMOTHY J. LEE	JAMEY VALDIVIA	ERIN McPHERSON	JV	9-29-21

NOTE:
FOR ACCURATE RIGHT OF WAY DATA, CONTACT RIGHT OF WAY ENGINEERING AT THE DISTRICT OFFICE.

Dist	COUNTY	ROUTE	POST MILES TOTAL PROJECT	SHEET No.	TOTAL SHEETS
04	Ala, CC	680	R11.0/R21.9, RO.0/RO.9	756	1710

REGISTERED CIVIL ENGINEER *Erin McPherson* DATE 9-29-21
 October 8, 2021
 PLANS APPROVAL DATE

ERIN D. McPHERSON
 No. C91111
 Exp. 3-31-24
 CIVIL
 STATE OF CALIFORNIA

THE STATE OF CALIFORNIA OR ITS OFFICERS OR AGENTS SHALL NOT BE RESPONSIBLE FOR THE ACCURACY OR COMPLETENESS OF SCANNED COPIES OF THIS PLAN SHEET.

WMH CORPORATION 55 South Market St Suite 1200 San Jose, CA 95113	ALAMEDA CTC 1111 Broadway Suite 800 Oakland, CA 94607
---	--

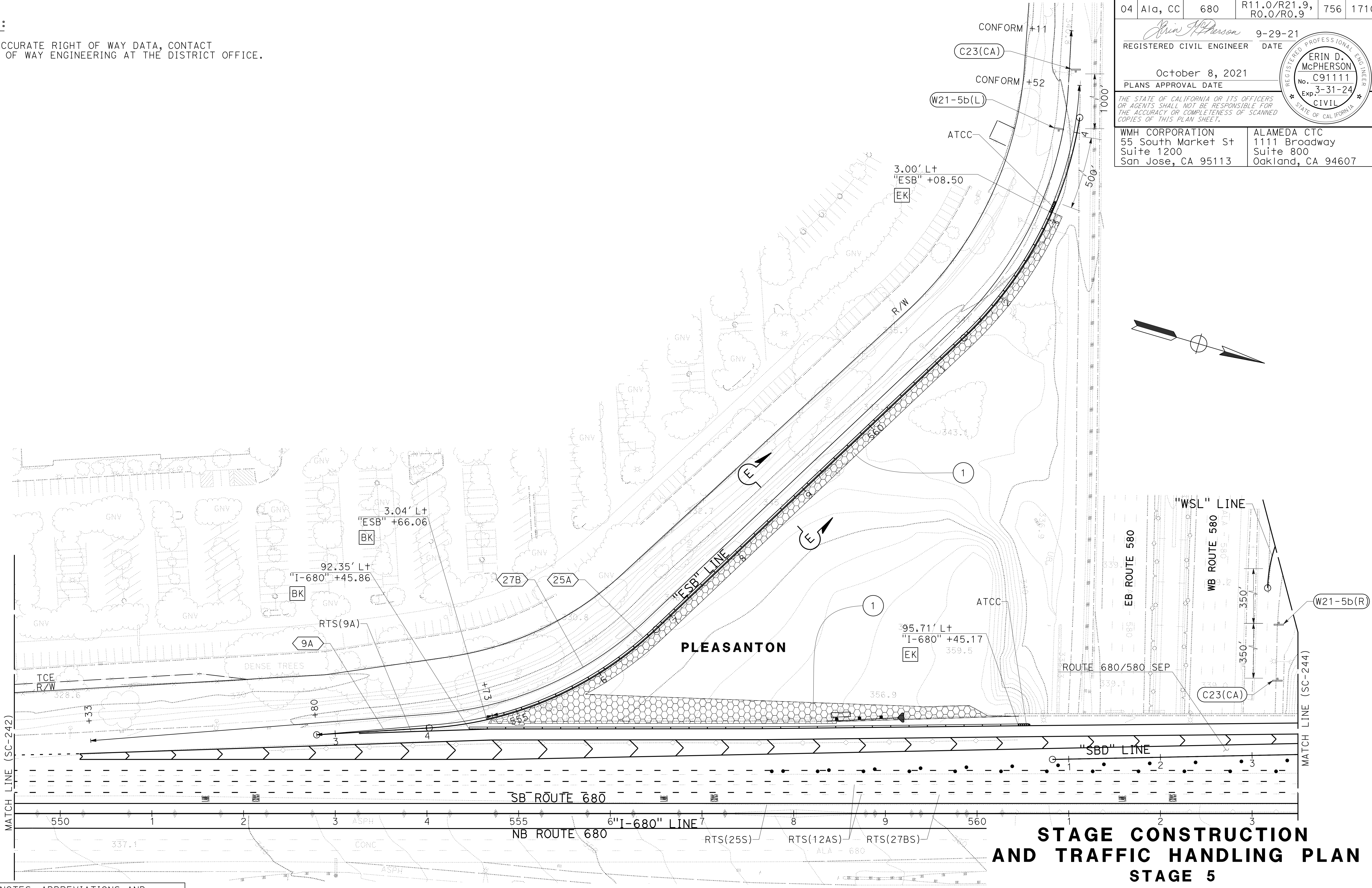

FOR NOTES, ABBREVIATIONS AND LEGEND, SEE SHEET SC-1 AND SC-226

APPROVED FOR STAGE CONSTRUCTION AND TRAFFIC HANDLING WORK ONLY

STAGE CONSTRUCTION AND TRAFFIC HANDLING PLAN
STAGE 5

SCALE: 1" = 50'

SC-243

Dist	COUNTY	ROUTE	POST MILES TOTAL PROJECT	SHEET No.	TOTAL SHEETS
04	Ala, CC	680	R11.0/R21.9, R0.0/R0.9	757	1710

<i>Erin McPherson</i>		9-29-21
REGISTERED CIVIL ENGINEER	DATE	
October 8, 2021		
PLANS APPROVAL DATE		
<small>THE STATE OF CALIFORNIA OR ITS OFFICERS OR AGENTS SHALL NOT BE RESPONSIBLE FOR THE ACCURACY OR COMPLETENESS OF SCANNED COPIES OF THIS PLAN SHEET.</small>		
WMH CORPORATION 55 South Market St Suite 1200 San Jose, CA 95113	ALAMEDA CTC 1111 Broadway Suite 800 Oakland, CA 94607	

NOTE:
FOR ACCURATE RIGHT OF WAY DATA, CONTACT
RIGHT OF WAY ENGINEERING AT THE DISTRICT OFFICE.

0:\00300\DRAWING\FINAL_P58E\0420000235m0244.dgn
 STATE OF CALIFORNIA - DEPARTMENT OF TRANSPORTATION
 Er Catrans
 CONSULTANT - FUNCTIONAL SUPERVISOR
 TIMOTHY J. LEE
 CALCULATED-DESIGNED BY
 BK
 CHECKED BY
 ERIN MCPHERSON
 REVISED BY
 JAMIE VALDIVIA
 DATE REVISID
 9-29-21
 JV

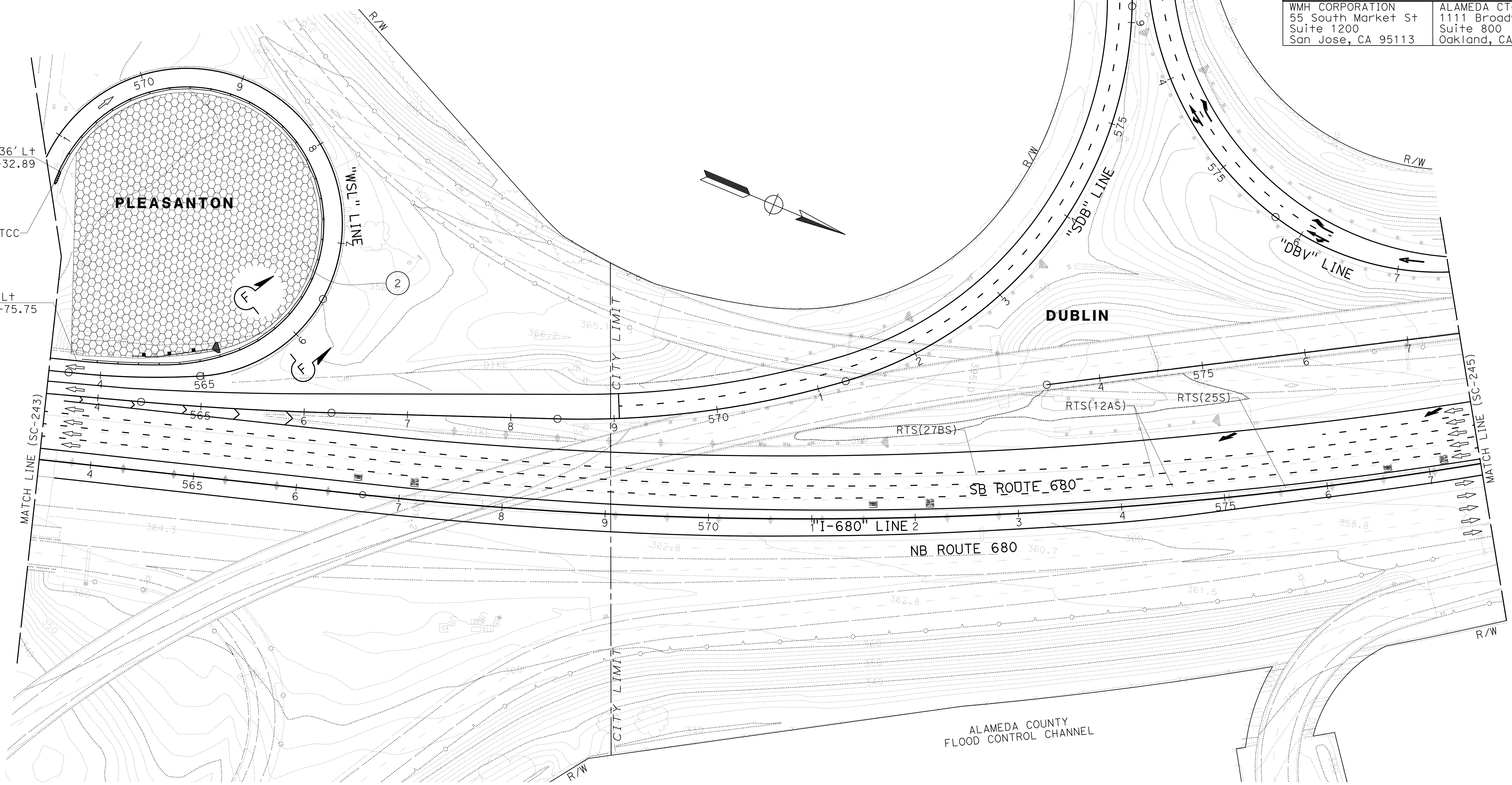

FOR NOTES, ABBREVIATIONS AND
LEGEND, SEE SHEET SC-1 AND SC-226

APPROVED FOR STAGE CONSTRUCTION AND TRAFFIC HANDLING WORK ONLY

**STAGE CONSTRUCTION
AND TRAFFIC HANDLING PLAN
STAGE 5**

SCALE: 1" = 50'

SC-244

LAST REVISION: DATE PLOTTED => 7-MAR-2022
 09-29-21 TIME PLOTTED => 11:59

Dist	COUNTY	ROUTE	POST MILES TOTAL PROJECT	SHEET No.	TOTAL SHEETS
04	Ala, CC	680	R11.0/R21.9, R0.0/R0.9	758	1710
			9-29-21		
REGISTERED CIVIL ENGINEER			DATE		
October 8, 2021			PLANS APPROVAL DATE		
WMH CORPORATION 55 South Market St Suite 1200 San Jose, CA 95113			ALAMEDA CTC 1111 Broadway Suite 800 Oakland, CA 94607		

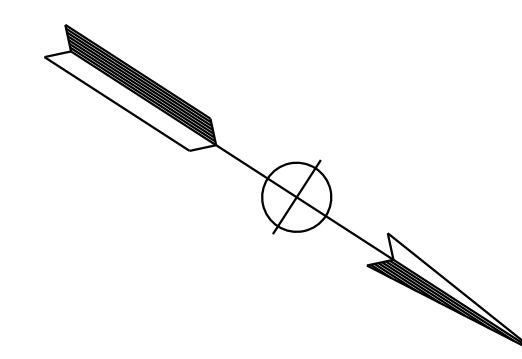

NOTE:
FOR ACCURATE RIGHT OF WAY DATA, CONTACT
RIGHT OF WAY ENGINEERING AT THE DISTRICT OFFICE.

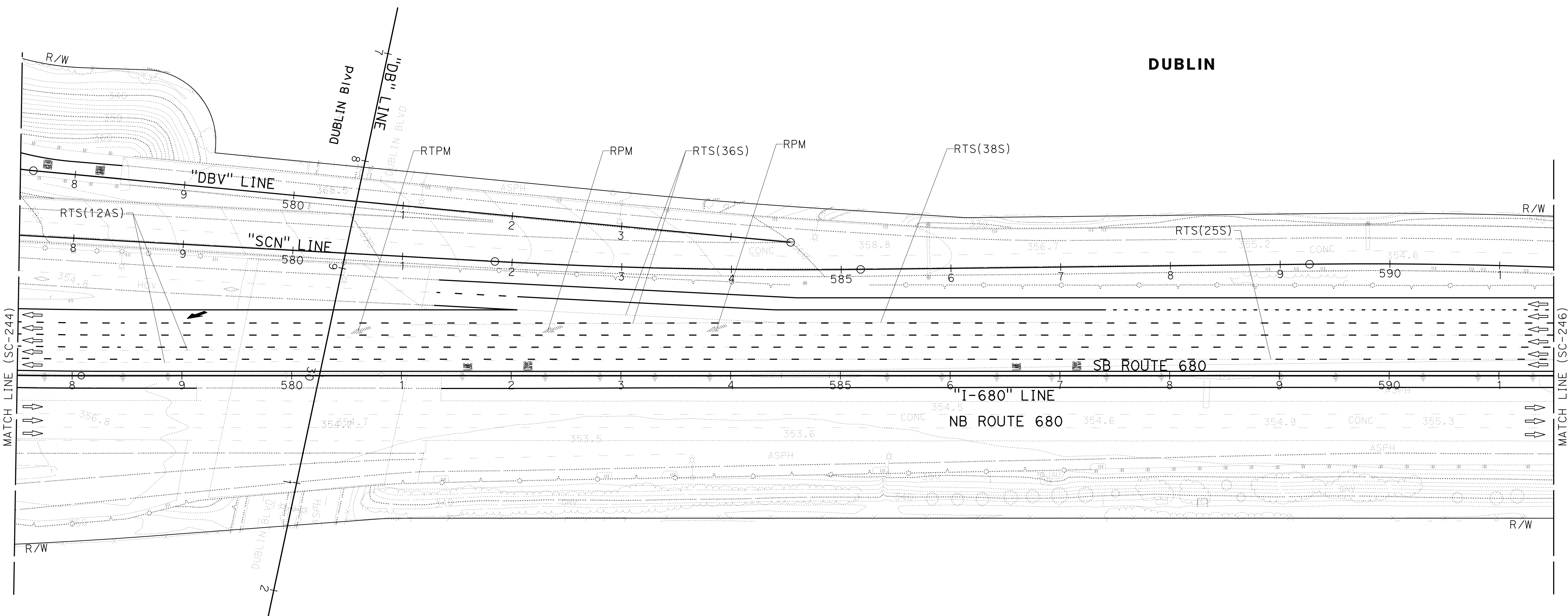

**STAGE CONSTRUCTION
AND TRAFFIC HANDLING PLAN
STAGE 5**

SCALE: 1" = 50'

SC-245

APPROVED FOR STAGE CONSTRUCTION AND TRAFFIC HANDLING WORK ONLY

FOR NOTES, ABBREVIATIONS AND
LEGEND, SEE SHEET SC-1 AND SC-226

O:\00300\DRAWING\FINAL_P58E\0420000235ma245.dgn
 STATE OF CALIFORNIA - DEPARTMENT OF TRANSPORTATION
 Ervin
 JAMES VALDIVIA
 ERIN McPHERSON
 CALCULATED-DESIGNED BY
 CHECKED BY
 SUPERVISOR
 TIMOTHY J. LEE
 CONSULTANT
 JAMES VALDIVIA
 ERIN McPHERSON
 REVISED BY
 DATE REVISED
 JV
 9-29-21

LAST REVISION: DATE PLOTTED => 7-MAR-2022
 09-29-21 TIME PLOTTED => 11:59

Dist	COUNTY	ROUTE	POST MILES TOTAL PROJECT	SHEET No.	TOTAL SHEETS
04	Ala, CC	680	R11.0/R21.9, R0.0/R0.9	759	1710
			9-29-21		
REGISTERED CIVIL ENGINEER			DATE		
October 8, 2021			PLANS APPROVAL DATE		
WMH CORPORATION 55 South Market St Suite 1200 San Jose, CA 95113			ALAMEDA CTC 1111 Broadway Suite 800 Oakland, CA 94607		

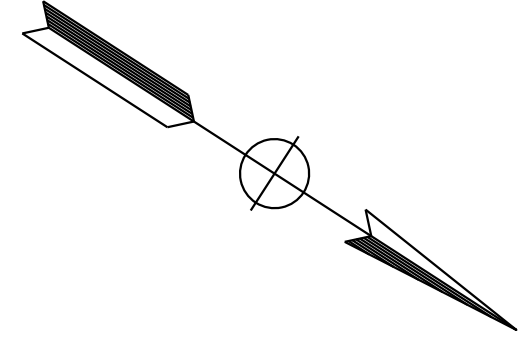

NOTE:
FOR ACCURATE RIGHT OF WAY DATA, CONTACT RIGHT OF WAY ENGINEERING AT THE DISTRICT OFFICE.

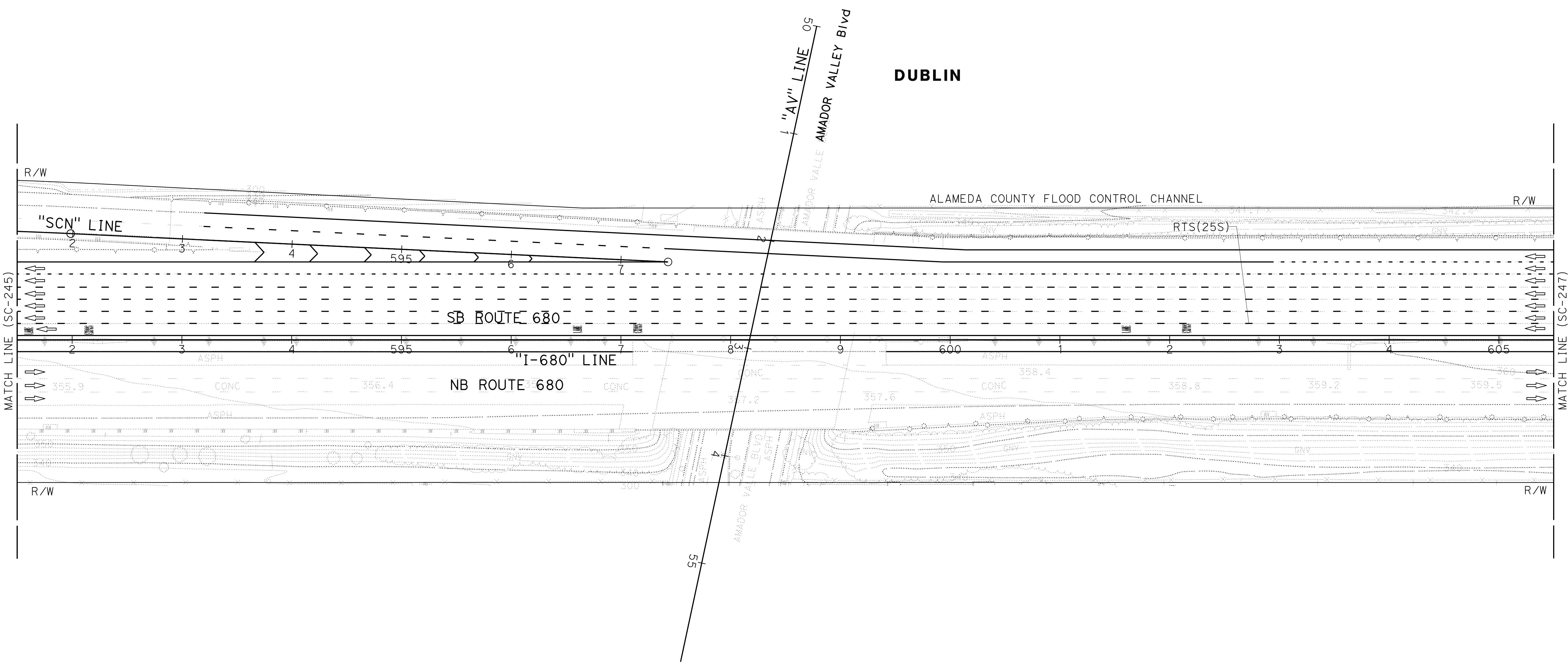

STAGE CONSTRUCTION AND TRAFFIC HANDLING PLAN STAGE 5

SCALE: 1" = 50'

SC-246

APPROVED FOR STAGE CONSTRUCTION AND TRAFFIC HANDLING WORK ONLY

FOR NOTES, ABBREVIATIONS AND LEGEND, SEE SHEET SC-1 AND SC-226

O:\00300\DRAWING\FINAL_P58E\0420000235ma246.dgn
 STATE OF CALIFORNIA - DEPARTMENT OF TRANSPORTATION
 Et Caltrans®
 CONSULTANT SUPERVISOR: JAMES VALDIVIA
 CHECKED BY: ERIN MCPHERSON
 REVISIONS:
 9-29-21
 DATE
 REVISED BY
 DATE
 DESIGNED BY
 CHECKED BY
 SUPERVISOR
 J. LEE
 J. LEE
 J. LEE

LAST REVISION: 09-29-21
 DATE PLOTTED => 7-MAR-2022
 TIME PLOTTED => 11:59

X:\680_SB_EXPRESS\000_CAD\Submittal\0420000235ma247.dgn
 STATE OF CALIFORNIA - DEPARTMENT OF TRANSPORTATION
 CONSULTANT FUNCTIONAL SUPERVISOR
 JAMEY VALDIVIA
 ERIN MCPHERSON
 TIMOTHY J. LEE
 REVISIONS: 09-29-21
 DATE PLOTTED: 3/21/2022 4:16:53 PM

NOTE:
 FOR ACCURATE RIGHT OF WAY DATA, CONTACT
 RIGHT OF WAY ENGINEERING AT THE DISTRICT OFFICE.

Dist	COUNTY	ROUTE	POST MILES TOTAL PROJECT	SHEET No.	TOTAL SHEETS
04	Ala, CC	680	R11.0/R21.9, R0.0/R0.9	760	1710

REGISTERED CIVIL ENGINEER DATE 9-29-21
 October 8, 2021
 PLANS APPROVAL DATE

ERIN D. MCPHERSON
 No. C91111
 Exp. 3-31-24
 CIVIL
 STATE OF CALIFORNIA

THE STATE OF CALIFORNIA OR ITS OFFICERS
 OR AGENTS SHALL NOT BE RESPONSIBLE FOR
 THE ACCURACY OR COMPLETENESS OF SCANNED
 COPIES OF THIS PLAN SHEET.

WMH CORPORATION 55 South Market St Suite 1200 San Jose, CA 95113	ALAMEDA CTC 1111 Broadway Suite 800 Oakland, CA 94607
---	--

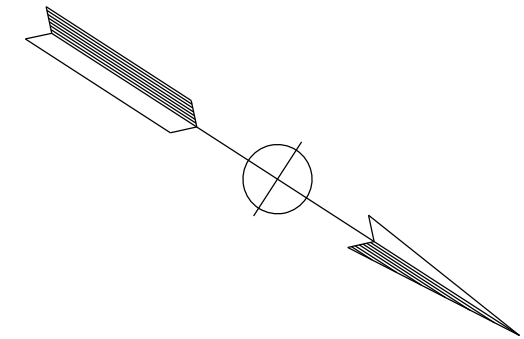

DUBLIN

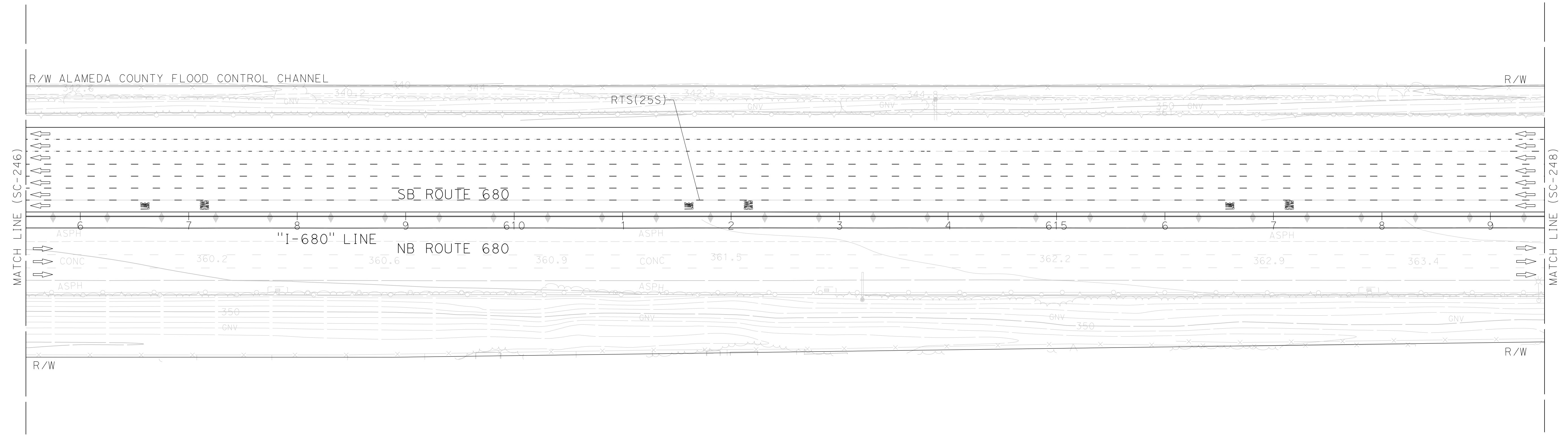

FOR NOTES, ABBREVIATIONS AND
 LEGEND, SEE SHEET SC-1 AND SC-226

APPROVED FOR STAGE CONSTRUCTION AND TRAFFIC HANDLING WORK ONLY

**STAGE CONSTRUCTION
 AND TRAFFIC HANDLING PLAN
 STAGE 5**

SCALE: 1" = 50'

SC-247

Dist	COUNTY	ROUTE	POST MILES TOTAL PROJECT	SHEET No.	TOTAL SHEETS
04	Ala, CC	680	R11.0/R21.9, R0.0/R0.9	761	1710

REGISTERED CIVIL ENGINEER DATE 9-29-21
 October 8, 2021
 PLANS APPROVAL DATE

ERIN D. McPHERSON
 No. C91111
 Exp. 3-31-24
 CIVIL
 STATE OF CALIFORNIA

THE STATE OF CALIFORNIA OR ITS OFFICERS OR AGENTS SHALL NOT BE RESPONSIBLE FOR THE ACCURACY OR COMPLETENESS OF SCANNED COPIES OF THIS PLAN SHEET.

WMH CORPORATION 55 South Market St Suite 1200 San Jose, CA 95113	ALAMEDA CTC 1111 Broadway Suite 800 Oakland, CA 94607
---	--

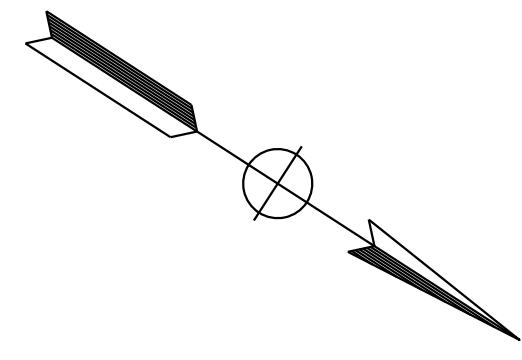

NOTE:
FOR ACCURATE RIGHT OF WAY DATA, CONTACT RIGHT OF WAY ENGINEERING AT THE DISTRICT OFFICE.

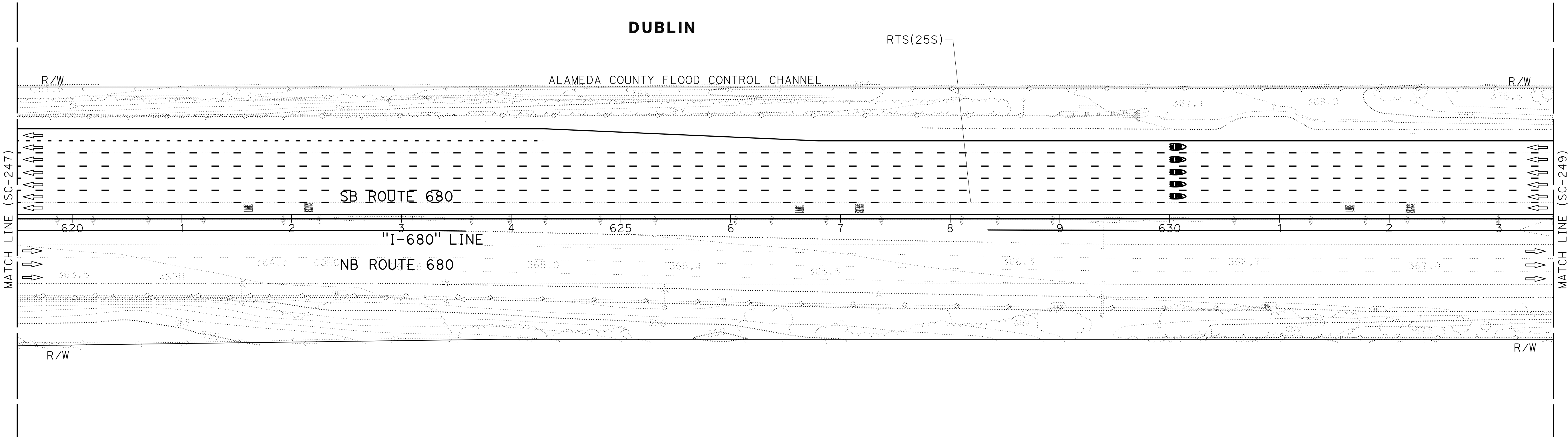

**STAGE CONSTRUCTION
AND TRAFFIC HANDLING PLAN
STAGE 5**

SCALE: 1" = 50'

SC-248

FOR NOTES, ABBREVIATIONS AND LEGEND, SEE SHEET SC-1 AND SC-226

APPROVED FOR STAGE CONSTRUCTION AND TRAFFIC HANDLING WORK ONLY

O:\00300\DRAWING\FINAL_P58E\0420000235ma248.dgn
 STATE OF CALIFORNIA - DEPARTMENT OF TRANSPORTATION
 Et Caltrans®
 CONSULTANT: FUNCTIONAL SUPERVISOR: TIMOTHY J. LEE
 CALCULATED/DESIGNED BY: JAMEY VALDIVIA
 CHECKED BY: ERIN McPHERSON
 REVISED BY: JV
 DATE REVISED: 9-29-21

LAST REVISION: 09-29-21 DATE PLOTTED => 7-MAR-2022 TIME PLOTTED => 12:00

STATE OF CALIFORNIA - DEPARTMENT OF TRANSPORTATION
Caltrans
 CONSULTANT: FUNCTIONAL SUPERVISOR: TIMOTHY J. LEE
 CALCULATED/DESIGNED BY: JAMEY VALDIVIA
 CHECKED BY: ERIN McPHERSON
 REVISED BY: JV
 DATE REVISED: 9-29-21

NOTE:
 FOR ACCURATE RIGHT OF WAY DATA, CONTACT
 RIGHT OF WAY ENGINEERING AT THE DISTRICT OFFICE.

Dist	COUNTY	ROUTE	POST MILES TOTAL PROJECT	SHEET No.	TOTAL SHEETS
04	Ala, CC	680	R11.0/R21.9, R0.0/R0.9	762	1710

REGISTERED CIVIL ENGINEER: *Erin McPherson* DATE: 9-29-21
 PLANS APPROVAL DATE: October 8, 2021

REGISTERED PROFESSIONAL ENGINEER
 ERIN D. McPHERSON
 No. C91111
 Exp. 3-31-24
 CIVIL
 STATE OF CALIFORNIA

THE STATE OF CALIFORNIA OR ITS OFFICERS OR AGENTS SHALL NOT BE RESPONSIBLE FOR THE ACCURACY OR COMPLETENESS OF SCANNED COPIES OF THIS PLAN SHEET.

WMH CORPORATION 55 South Market St Suite 1200 San Jose, CA 95113	ALAMEDA CTC 1111 Broadway Suite 800 Oakland, CA 94607
---	--

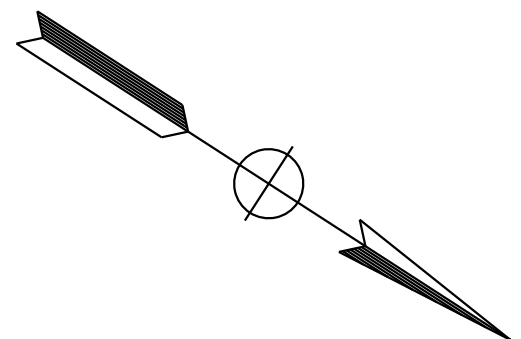

DUBLIN

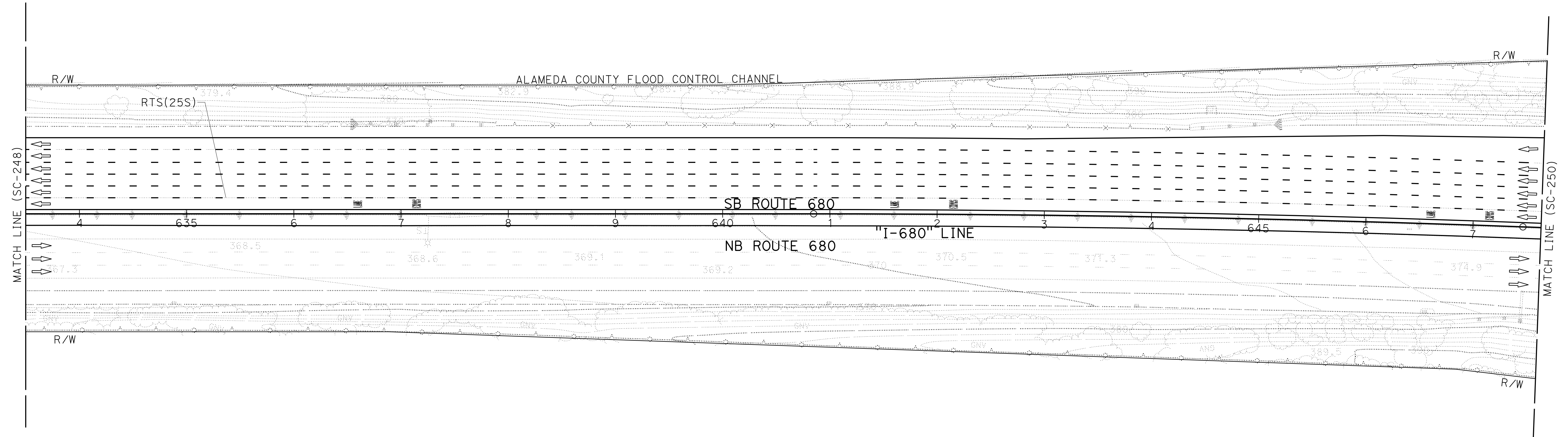

FOR NOTES, ABBREVIATIONS AND
 LEGEND, SEE SHEET SC-1 AND SC-226

APPROVED FOR STAGE CONSTRUCTION AND TRAFFIC HANDLING WORK ONLY

**STAGE CONSTRUCTION
 AND TRAFFIC HANDLING PLAN
 STAGE 5**

SCALE: 1" = 50'

SC-249

LAST REVISION: 09-29-21 DATE PLOTTED => 7-MAR-2022 TIME PLOTTED => 12:00

Dist	COUNTY	ROUTE	POST MILES TOTAL PROJECT	SHEET No.	TOTAL SHEETS
04	Ala, CC	680	R11.0/R21.9, RO.0/RO.9	763	1710
			9-29-21		
REGISTERED CIVIL ENGINEER			DATE		
			October 8, 2021		
PLANS APPROVAL DATE					
<small>THE STATE OF CALIFORNIA OR ITS OFFICERS OR AGENTS SHALL NOT BE RESPONSIBLE FOR THE ACCURACY OR COMPLETENESS OF SCANNED COPIES OF THIS PLAN SHEET.</small>					
WMH CORPORATION 55 South Market St Suite 1200 San Jose, CA 95113			ALAMEDA CTC 1111 Broadway Suite 800 Oakland, CA 94607		

NOTE:
FOR ACCURATE RIGHT OF WAY DATA, CONTACT
RIGHT OF WAY ENGINEERING AT THE DISTRICT OFFICE.

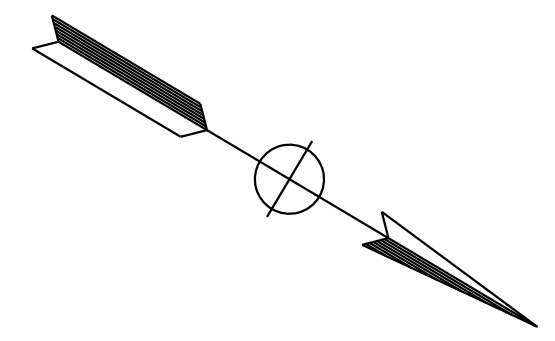

O:\00300\DRAWING\FINAL_P58E\0420000235ma250.dgn
 STATE OF CALIFORNIA - DEPARTMENT OF TRANSPORTATION
 Et Caltrans®
 USERNAME => p302438
 DGN FILE => 0420000235ma250.dgn

CALCULATED-DESIGNED BY	JAMEY VALDIVIA
CHECKED BY	ERIN McPHERSON
CONSULTANT FUNCTIONAL SUPERVISOR	TIMOTHY J. LEE
REVISOR	JV
DATE REVISED	9-29-21

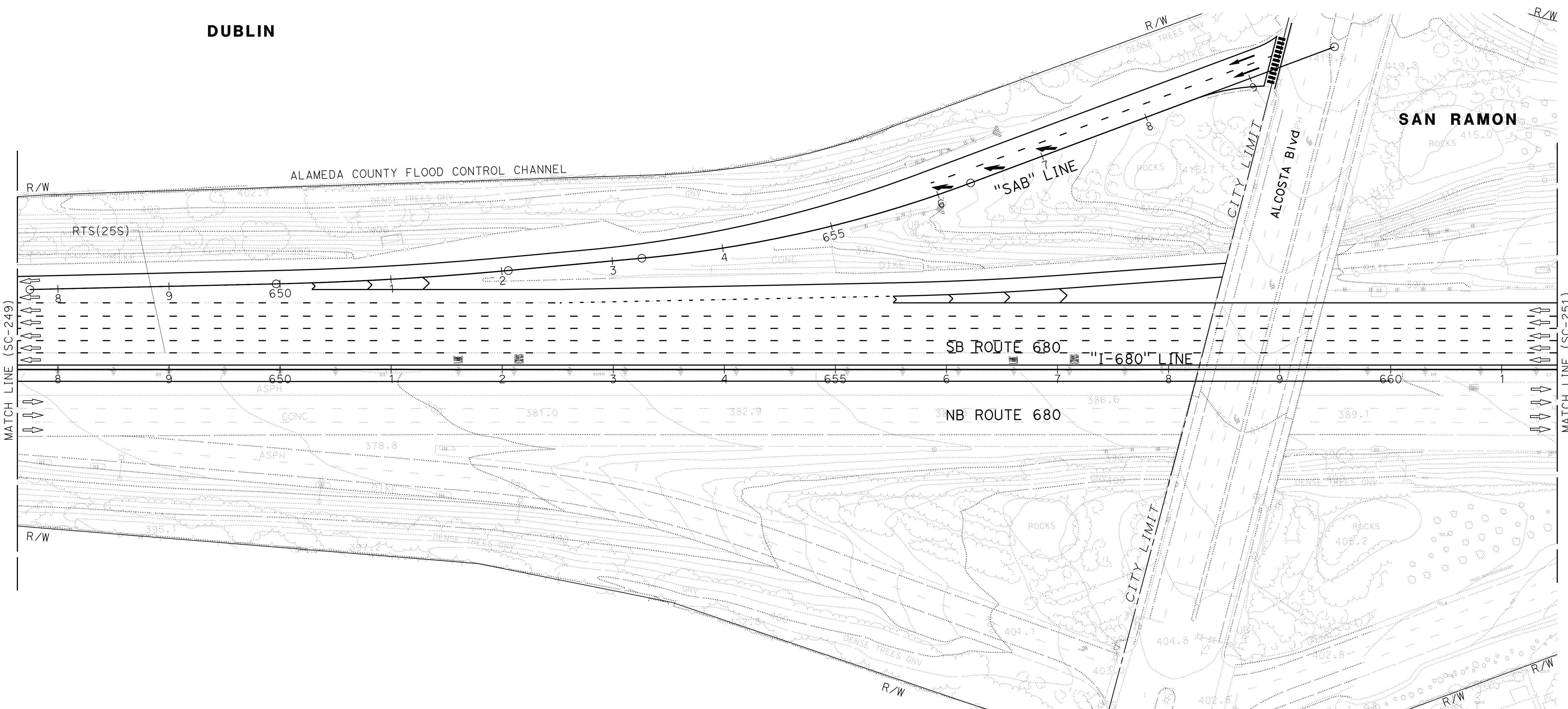

FOR NOTES, ABBREVIATIONS AND
LEGEND, SEE SHEET SC-1 AND SC-226

APPROVED FOR STAGE CONSTRUCTION AND TRAFFIC HANDLING WORK ONLY

**STAGE CONSTRUCTION
AND TRAFFIC HANDLING PLAN
STAGE 5**

SCALE: 1" = 50'

SC-250

Dist	COUNTY	ROUTE	POST MILES TOTAL PROJECT	SHEET No.	TOTAL SHEETS
04	Ala, CC	680	R11.0/R21.9, R0.0/R0.9	764	1710
			9-29-21		
REGISTERED CIVIL ENGINEER			DATE		
October 8, 2021			PLANS APPROVAL DATE		
<small>THE STATE OF CALIFORNIA OR ITS OFFICERS OR AGENTS SHALL NOT BE RESPONSIBLE FOR THE ACCURACY OR COMPLETENESS OF SCANNED COPIES OF THIS PLAN SHEET.</small>					
WMH CORPORATION 55 South Market St Suite 1200 San Jose, CA 95113			ALAMEDA CTC 1111 Broadway Suite 800 Oakland, CA 94607		

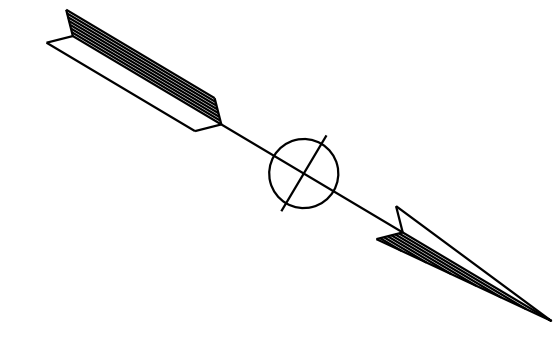

NOTE:
FOR ACCURATE RIGHT OF WAY DATA, CONTACT
RIGHT OF WAY ENGINEERING AT THE DISTRICT OFFICE.

		JV	9-29-21				
		REVISOR	DATE				
	JAMEY VALDIVIA	ERIN McPHERSON					
	CALCULATED-DESIGNED BY	CHECKED BY					
	TIMOTHY J. LEE						
	CONSULTANT	FUNCTIONAL SUPERVISOR					
	STATE OF CALIFORNIA	DEPARTMENT OF TRANSPORTATION					

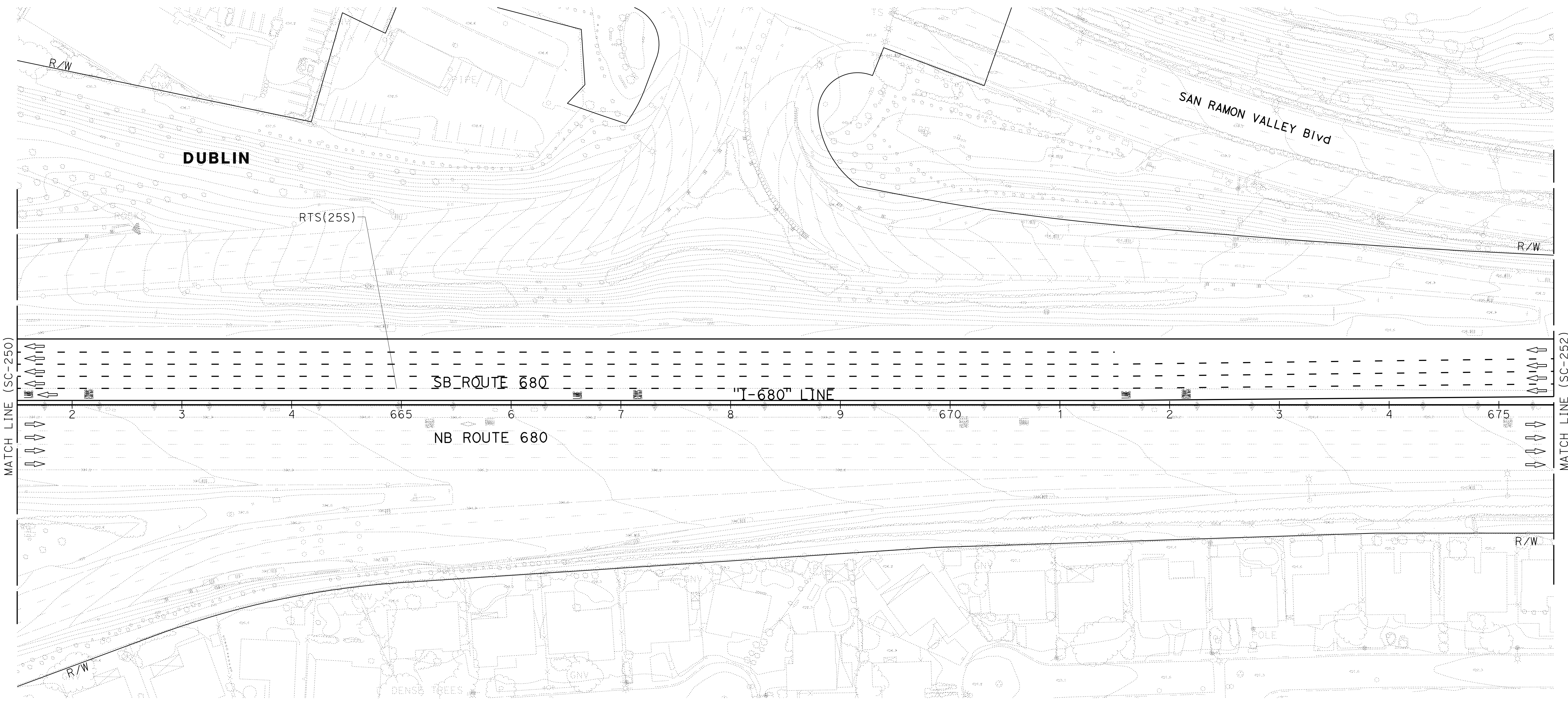

FOR NOTES, ABBREVIATIONS AND
LEGEND, SEE SHEET SC-1 AND SC-226

APPROVED FOR STAGE CONSTRUCTION AND TRAFFIC HANDLING WORK ONLY

STAGE CONSTRUCTION AND TRAFFIC HANDLING PLAN STAGE 5

SCALE: 1" = 50'

SC-251

LAST REVISION: 09-29-21 12:00
DATE PLOTTED => 7-MAR-2022
TIME PLOTTED => 12:00

Dist	COUNTY	ROUTE	POST MILES TOTAL PROJECT	SHEET No.	TOTAL SHEETS
04	Ala, CC	680	R11.0/R21.9, R0.0/R0.9	765	1710
			9-29-21		
REGISTERED CIVIL ENGINEER			DATE		
October 8, 2021			PLANS APPROVAL DATE		
<small>THE STATE OF CALIFORNIA OR ITS OFFICERS OR AGENTS SHALL NOT BE RESPONSIBLE FOR THE ACCURACY OR COMPLETENESS OF SCANNED COPIES OF THIS PLAN SHEET.</small>					
WMH CORPORATION 55 South Market St Suite 1200 San Jose, CA 95113			ALAMEDA CTC 1111 Broadway Suite 800 Oakland, CA 94607		

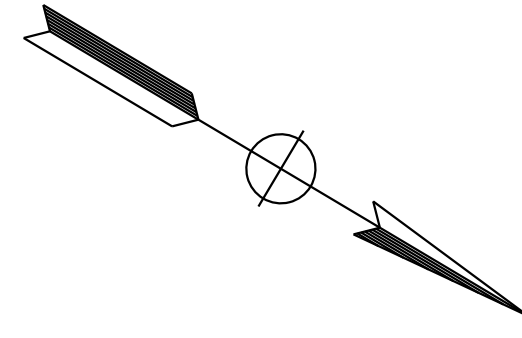

NOTE:
FOR ACCURATE RIGHT OF WAY DATA, CONTACT
RIGHT OF WAY ENGINEERING AT THE DISTRICT OFFICE.

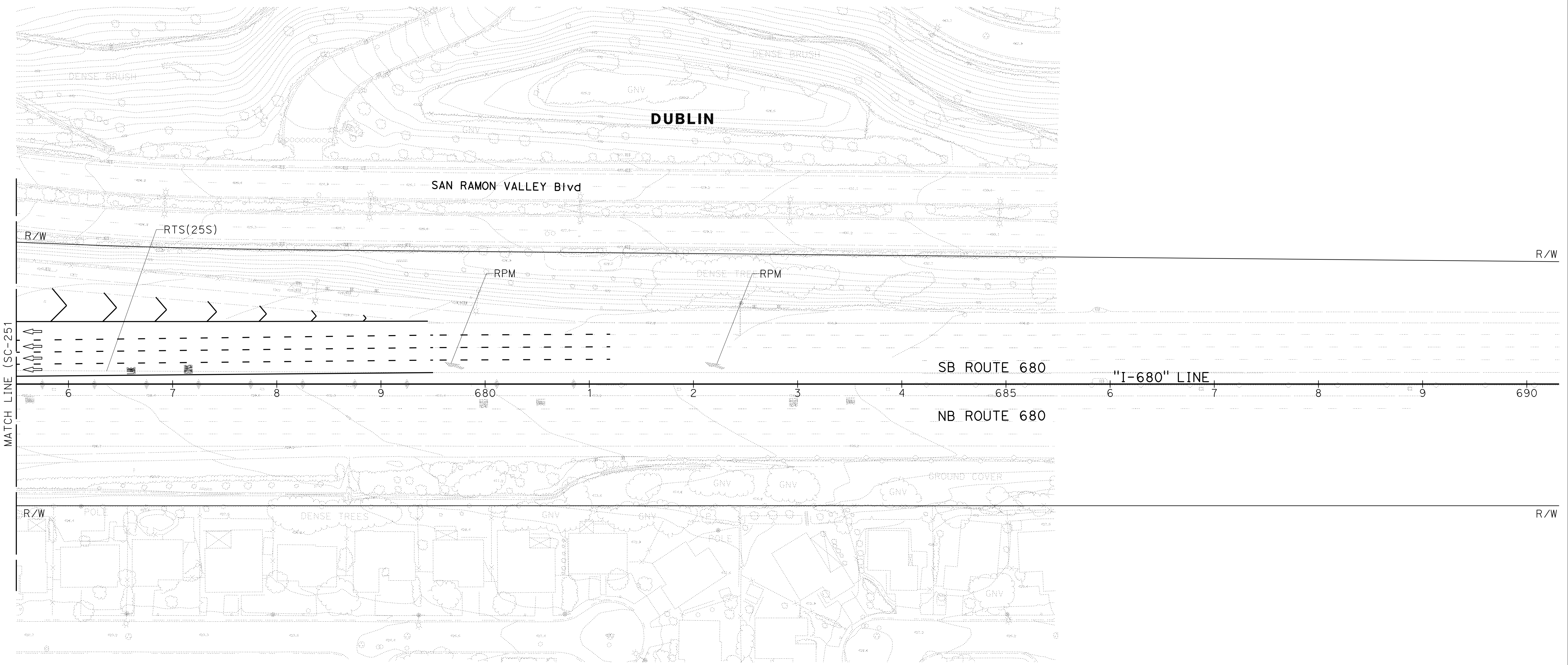

O:\00300\DRAWING\FINAL_P58E\0420000235ma252.dgn
 STATE OF CALIFORNIA - DEPARTMENT OF TRANSPORTATION
 Et Caltrans®
 CONSULTANT SUPERVISOR: JAMEY VALDIVIA
 CHECKED BY: ERIN McPHERSON
 DESIGNED BY: ERIN McPHERSON
 REVISED BY: J.V.
 DATE REVISED: 9-29-21
 CONSULTANT: TIMOTHY J. LEE

FOR NOTES, ABBREVIATIONS AND
LEGEND, SEE SHEET SC-1 AND SC-226

APPROVED FOR STAGE CONSTRUCTION AND TRAFFIC HANDLING WORK ONLY

STAGE CONSTRUCTION AND TRAFFIC HANDLING PLAN STAGE 5

SCALE: 1" = 50'

SC-252

LAST REVISION: 09-29-21 DATE PLOTTED => 7-MAR-2022 TIME PLOTTED => 12:00

Dist	COUNTY	ROUTE	POST MILES TOTAL PROJECT	SHEET No.	TOTAL SHEETS
04	Ala, CC	680	R11.0/R21.9, R0.0/R0.9	766	1710
			9-29-21		
REGISTERED CIVIL ENGINEER			DATE		
October 8, 2021			PLANS APPROVAL DATE		
WMH CORPORATION 55 South Market St Suite 1200 San Jose, CA 95113			ALAMEDA CTC 1111 Broadway Suite 800 Oakland, CA 94607		

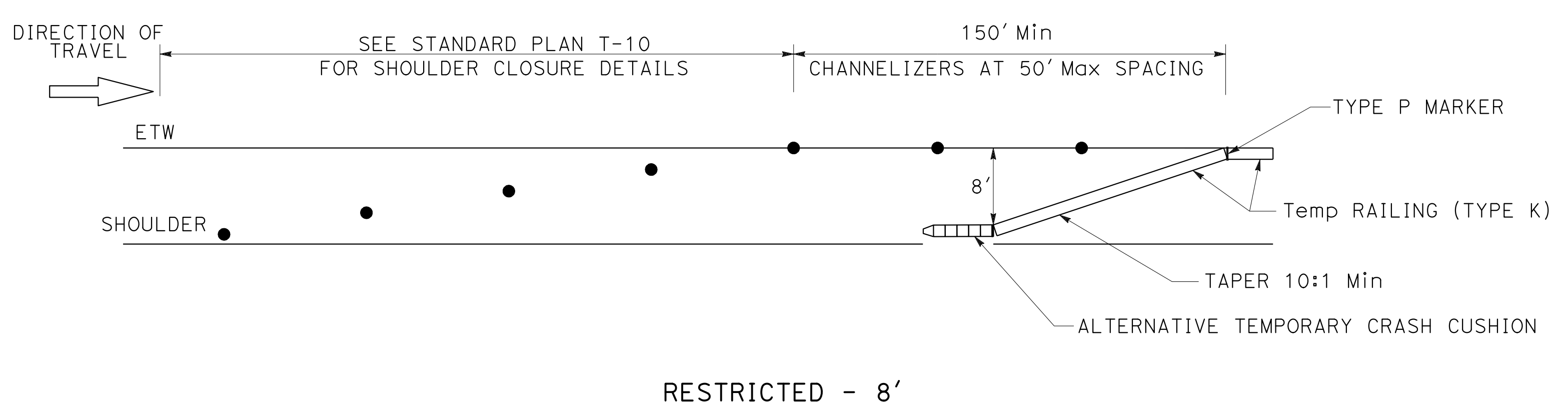
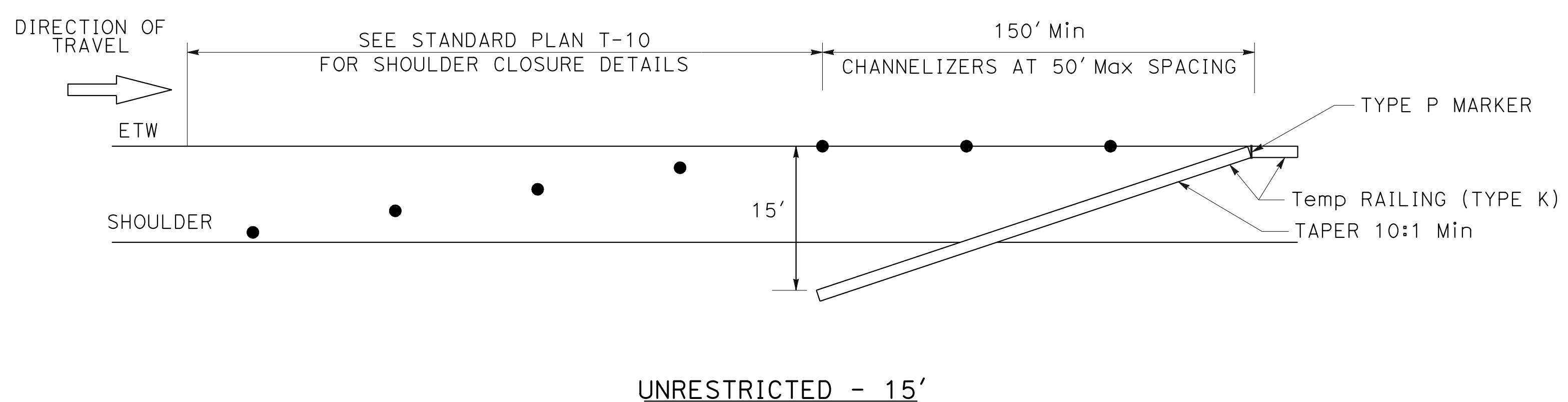

Temp RAILING (TYPE K) APPROACH TAPER

STAGE CONSTRUCTION DETAILS

NO SCALE

SCD-1

		JV			
		9-29-21			
	JAMEY VALDIVIA	ERIN McPHERSON			
	CALCULATED-DESIGNED BY	CHECKED BY			
	TIMOTHY J. LEE				
	CONSULTANT - FUNCTIONAL SUPERVISOR				
	DEPARTMENT OF TRANSPORTATION				
	STATE OF CALIFORNIA				
	Caltrans				

Dist	COUNTY	ROUTE	POST MILES TOTAL PROJECT	SHEET No.	TOTAL SHEETS
04	Ala, CC	680	R11.0/R21.9, R0.0/R0.9	767	1710

Erin D. McPherson 9-29-21
 REGISTERED CIVIL ENGINEER DATE

October 8, 2021
 PLANS APPROVAL DATE

THE STATE OF CALIFORNIA OR ITS OFFICERS
 OR AGENTS SHALL NOT BE RESPONSIBLE FOR
 THE ACCURACY OR COMPLETENESS OF SCANNED
 COPIES OF THIS PLAN SHEET.

ERIN D. McPHERSON
 No. C91111
 Exp. 3-31-24
 CIVIL
 STATE OF CALIFORNIA

WMH CORPORATION ALAMEDA CTC
 55 South Market St 1111 Broadway
 Suite 1200 Suite 800
 San Jose, CA 95113 Oakland, CA 94607

NOTE:
 1. SAFETY EDGE MUST BE PROVIDED WHERE MAXIMUM VERTICAL DROP BETWEEN ADJACENT LANES EXCEEDS 0.15'.

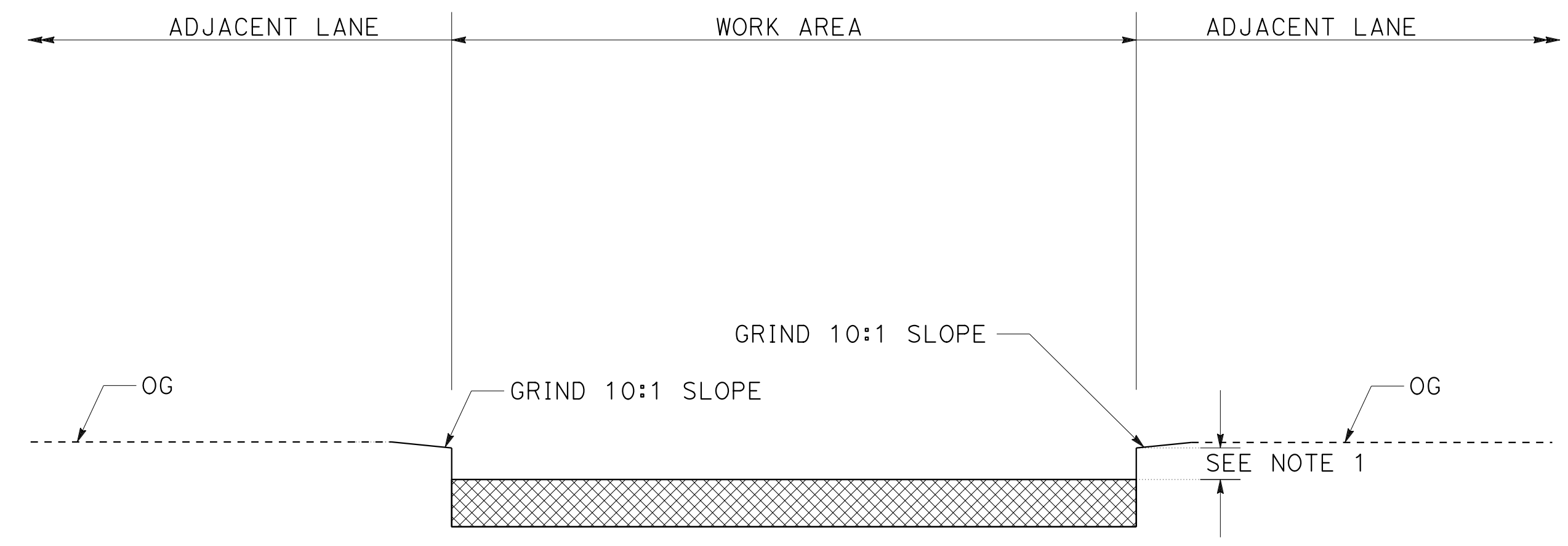

SAFETY EDGE DETAIL
 FOR HMA SECTIONS

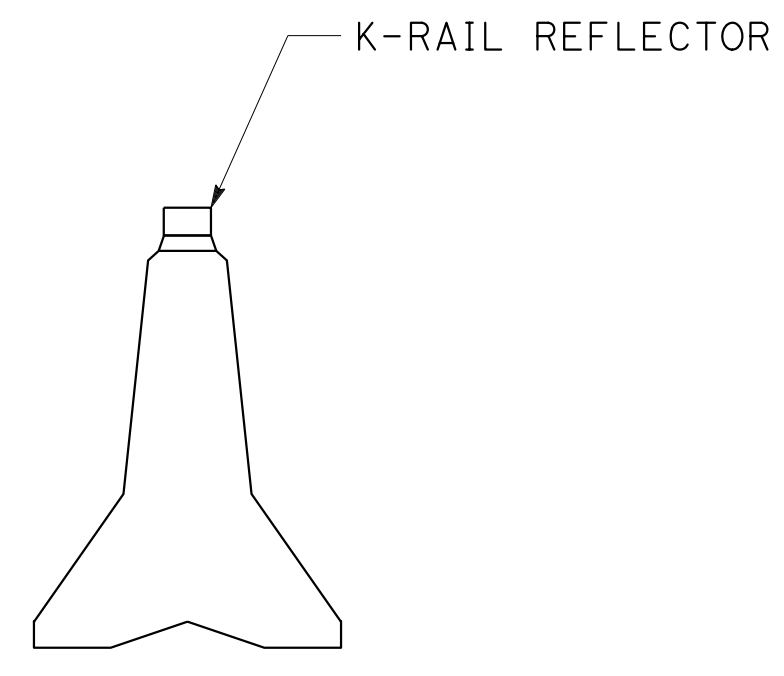

TEMPORARY RAILING (TYPE K) REFLECTOR DETAIL

RADIUS (R) OF CURVE	APPROXIMATE SPACING FOR REFLECTOR ON HORIZONTAL CURVES
50'	20'
115'	25'
180'	35'
250'	40'
300'	40'
400'	40'
500'	40'
600'	40'
700'	75'
800'	80'
900'	85'
1000'	90'

STAGE CONSTRUCTION DETAILS

NO SCALE

SCD-2

O:\0030\UDRAFT\ING\FINAL_P58E\0420000235mb002.dgn
 STATE OF CALIFORNIA - DEPARTMENT OF TRANSPORTATION
 Et Caltrans®
 CONSULTANT SUPERVISOR
 JAMES VALDIVIA
 ERIN McPHERSON
 CHECKED BY
 TIMOTHY J. LEE
 DESIGNED BY
 JAMES VALDIVIA
 ERIN McPHERSON
 REVISIONS
 REVISED BY
 DATE
 DATE REVISED
 9-29-21

Dist	COUNTY	ROUTE	POST MILES TOTAL PROJECT	SHEET No.	TOTAL SHEETS
04	Ala, CC	680	R11.0/R21.9, RO.0/RO.9	768	1710

REGISTERED CIVIL ENGINEER DATE 9-29-21
 October 8, 2021
 PLANS APPROVAL DATE

ERIN D. McPHERSON
 No. C91111
 Exp. 3-31-24
 CIVIL
 STATE OF CALIFORNIA

THE STATE OF CALIFORNIA OR ITS OFFICERS OR AGENTS SHALL NOT BE RESPONSIBLE FOR THE ACCURACY OR COMPLETENESS OF SCANNED COPIES OF THIS PLAN SHEET.

WMH CORPORATION 55 South Market St Suite 1200 San Jose, CA 95113	ALAMEDA CTC 1111 Broadway Suite 800 Oakland, CA 94607
---	--

NOTE:

1. FOR ACCURATE RIGHT OF WAY DATA, CONTACT RIGHT OF WAY ENGINEERING AT THE DISTRICT OFFICE.

LEGEND:

- PROPOSED STRIPE
- EXISTING STRIPE
- W OFFSET DISTANCE
- L LENGTH OF TAPER

W (FT)	L (FT)
1	55
2	110
3	165
4	220
5	275
6	330
7	385
8	440
9	495
10	550
11	605
12	660
13	715
14	770
15	825

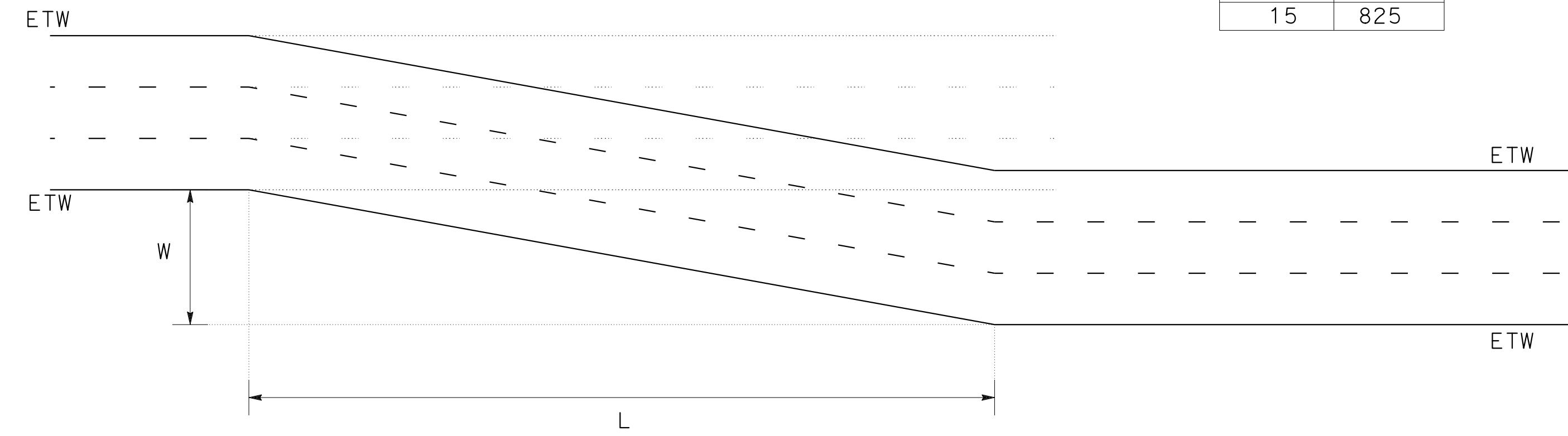

LANE TRANSITION TAPER LENGTH DETAIL

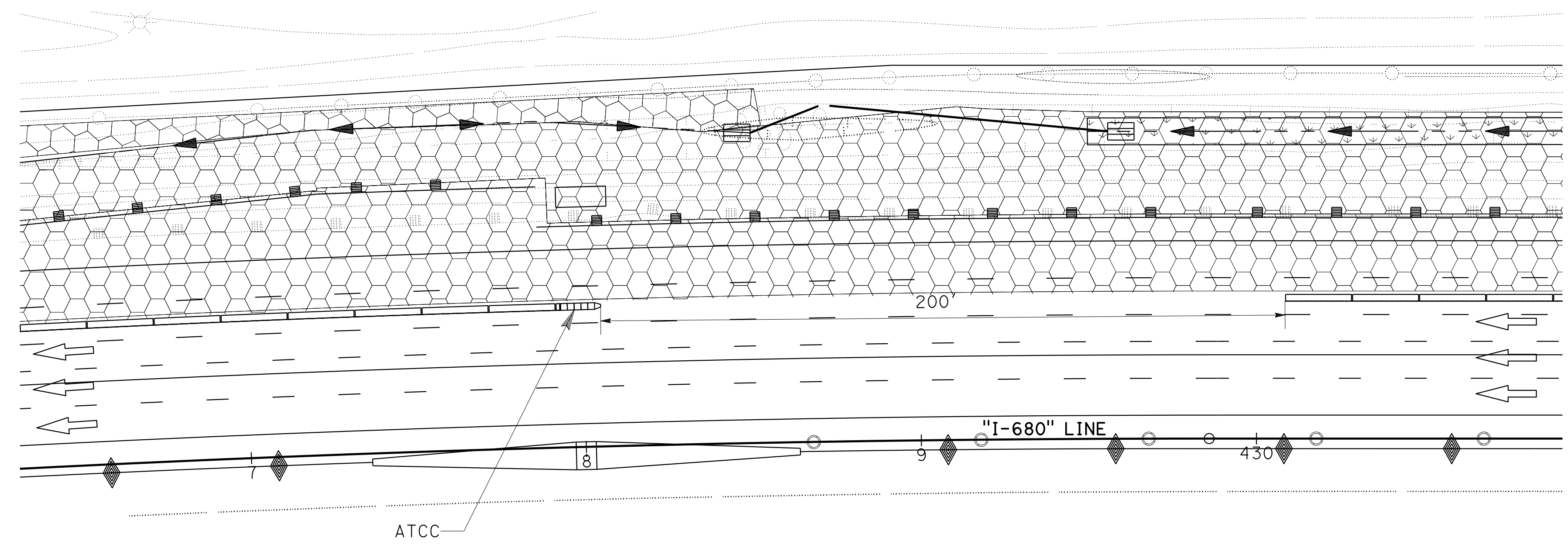

Temp RAILING (TYPE K) OPENING DETAIL

STAGE CONSTRUCTION DETAILS

NO SCALE

SCD-3

O:\0030\DRAWING\FINAL_P58E\0420000235mb003.dgn
 STATE OF CALIFORNIA - DEPARTMENT OF TRANSPORTATION
 Et Caltrans®
 CONSULTANT FUNCTIONAL SUPERVISOR: TIMOTHY J. LEE
 CALCULATED/DESIGNED BY: JAMEY VALDIVIA
 CHECKED BY: ERIN McPHERSON
 REVISED BY: J.V.
 DATE REVISED: 9-29-21

Dist	COUNTY	ROUTE	POST MILES TOTAL PROJECT	SHEET No.	TOTAL SHEETS
04	Ala, CC	680	R11.0/R21.9, RO.0/RO.9	769	1710
			9-29-21		
REGISTERED CIVIL ENGINEER			DATE		
			October 8, 2021		
			PLANS APPROVAL DATE		
<small>THE STATE OF CALIFORNIA OR ITS OFFICERS OR AGENTS SHALL NOT BE RESPONSIBLE FOR THE ACCURACY OR COMPLETENESS OF SCANNED COPIES OF THIS PLAN SHEET.</small>					
WMH CORPORATION 55 South Market St San Jose, CA 95113			ALAMEDA CTC 1111 Broadway Suite 800 Oakland, CA 94607		



NOTE:

1. WORK ON THIS SHEET SHOWS MCB STORAGE AND PLACEMENT FOR PAVEMENT REHABILITATION IN STAGES 2, 3 AND 4. (STA 156+59 TO STA 204+86).

LEGEND:

- WORK ZONE
- LANE OPEN TO TRAFFIC

ABBREVIATION:

MCB MOVABLE CONCRETE BARRIER

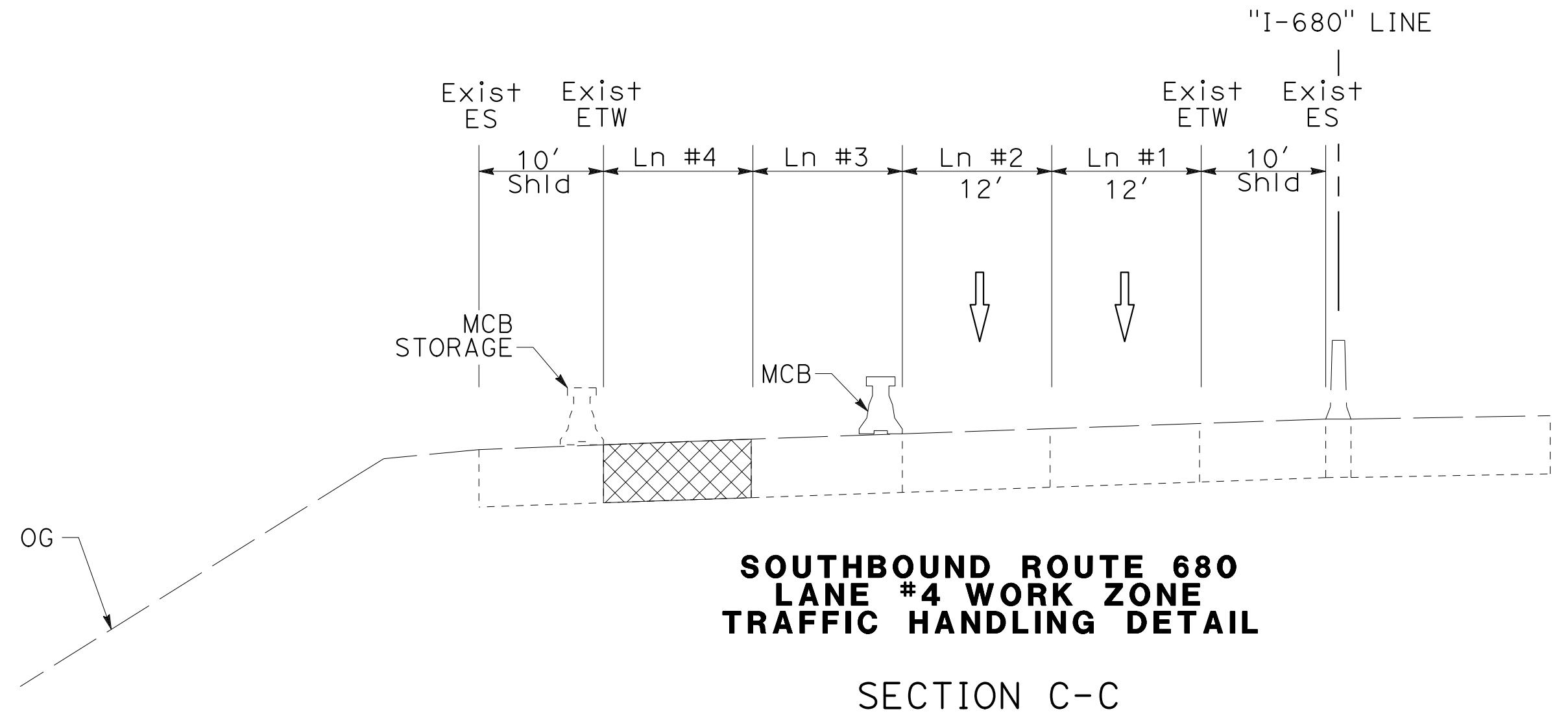
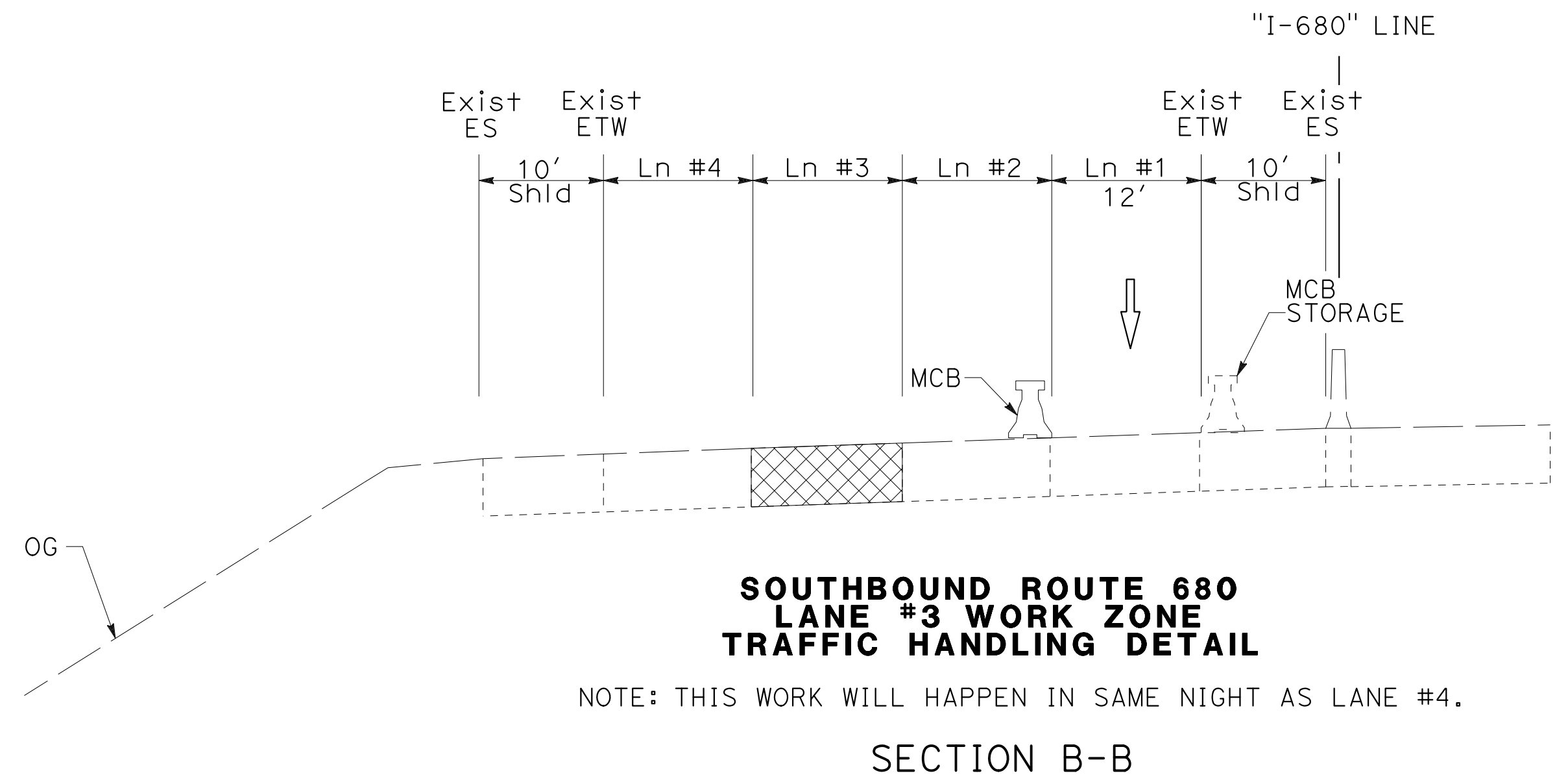
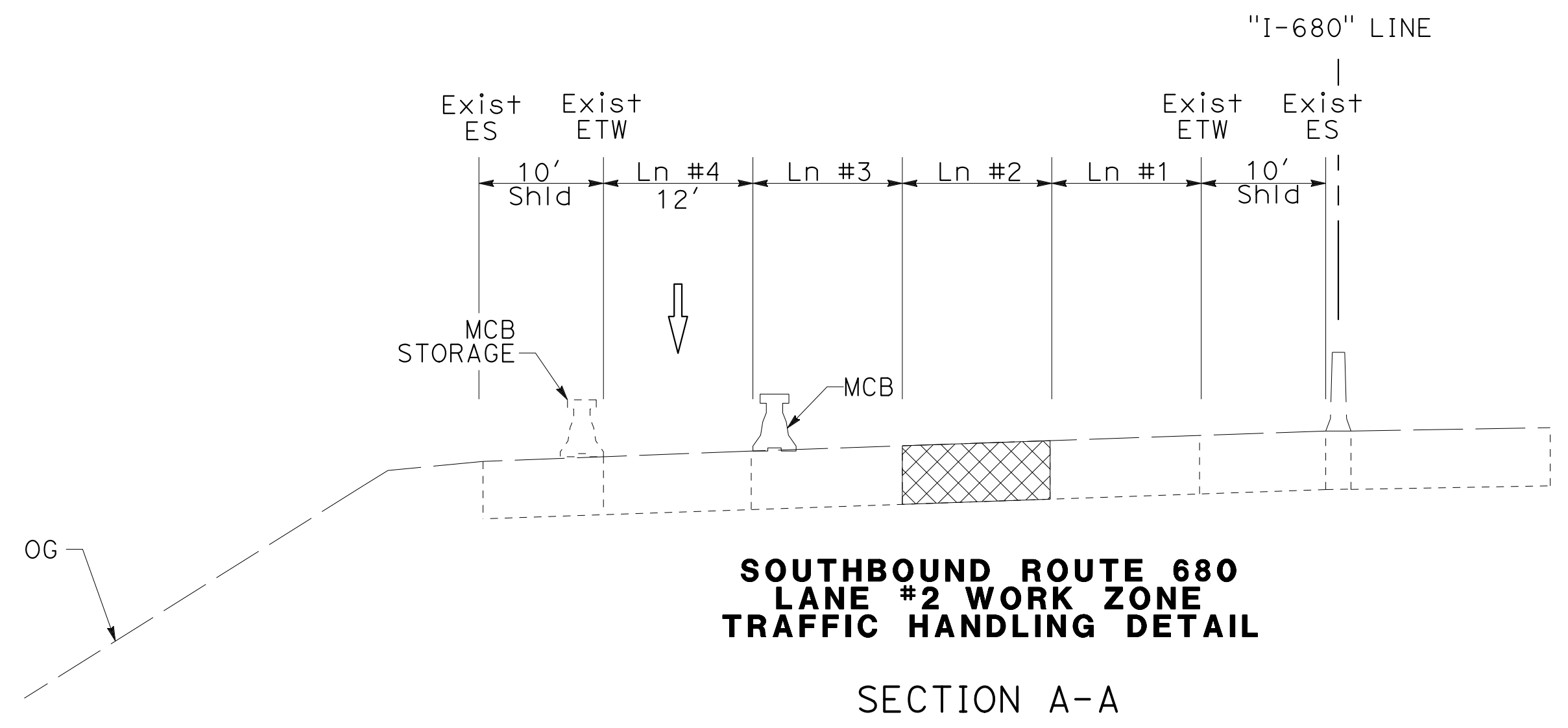

STAGE CONSTRUCTION DETAILS

NO SCALE

SCD-4

DESIGNED BY	JV	DATE	9-29-21
REVISOR	ERIN MCPHERSON	DATE	
CHECKED BY	TIMOTHY J. LEE	DATE	
DESIGNED BY	JAMEY VALDIVIA	DATE	
CHECKED BY	ERIN MCPHERSON	DATE	

0:\0030\DRAWING\FINAL_P58E\0420000235mb004.dgn

Dist	COUNTY	ROUTE	POST MILES TOTAL PROJECT	SHEET No.	TOTAL SHEETS
04	Ala, CC	680	R11.0/R21.9, RO.0/RO.9	770	1710

ERIN D. McPHERSON
 REGISTERED CIVIL ENGINEER
 DATE: 9-29-21
 October 8, 2021
 PLANS APPROVAL DATE

ERIN D. McPHERSON
 No. C91111
 Exp. 3-31-24
 CIVIL
 STATE OF CALIFORNIA

WMH CORPORATION
 55 South Market St
 Suite 1200
 San Jose, CA 95113

ALAMEDA CTC
 1111 Broadway
 Suite 800
 Oakland, CA 94607

NOTES:

- DO NOT INSTALL EDGE LINE STRIPING UNTIL PAVEMENT REHAB WORK IS COMPLETED.
- PLASTIC TRAFFIC DRUMS TO REMAIN UNLESS TRAFFIC IS USING LANE #1 DURING ALLOWABLE WORK WINDOW
- LANE #1 CONSTRUCTED IN EARLIER STAGE CAN BE USED TO ACCOMODATE PAVEMENT REHABILITATION DURING ALLOWABLE WORK WINDOW.
- WORK ON THIS SHEET SHOWS MCB STORAGE AND PLACEMENT FOR PAVEMENT REHABILITATION IN STAGES 2, 3 AND 4.

LEGEND:

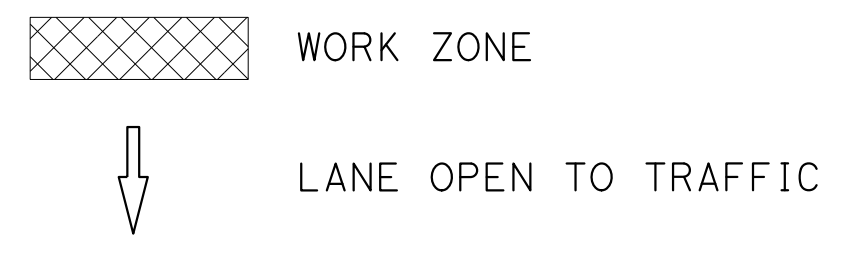

ABBREVIATION:

MCB MOVABLE CONCRETE BARRIER

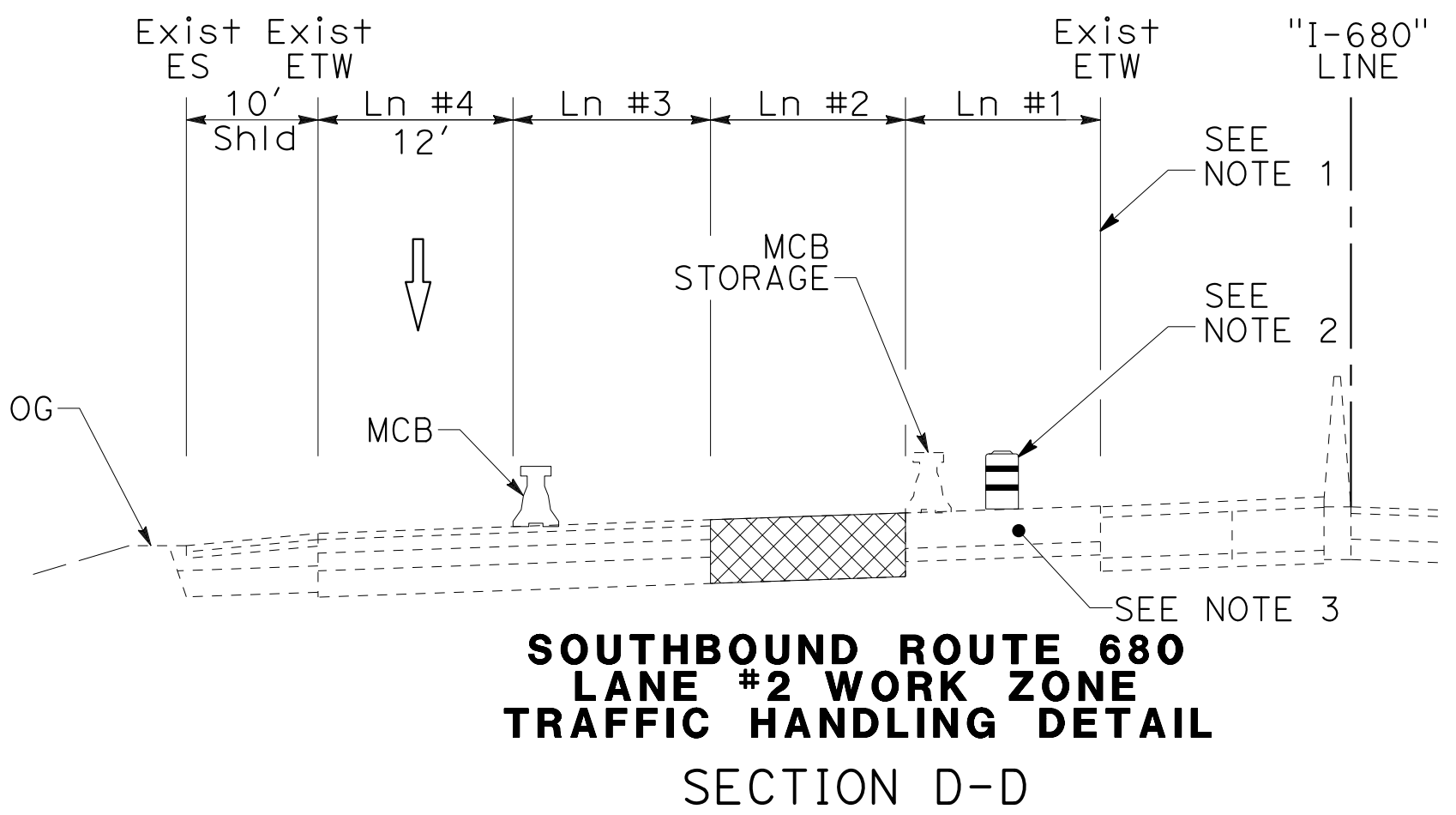

**SOUTHBOUND ROUTE 680
LANE #2 WORK ZONE
TRAFFIC HANDLING DETAIL
SECTION D-D**

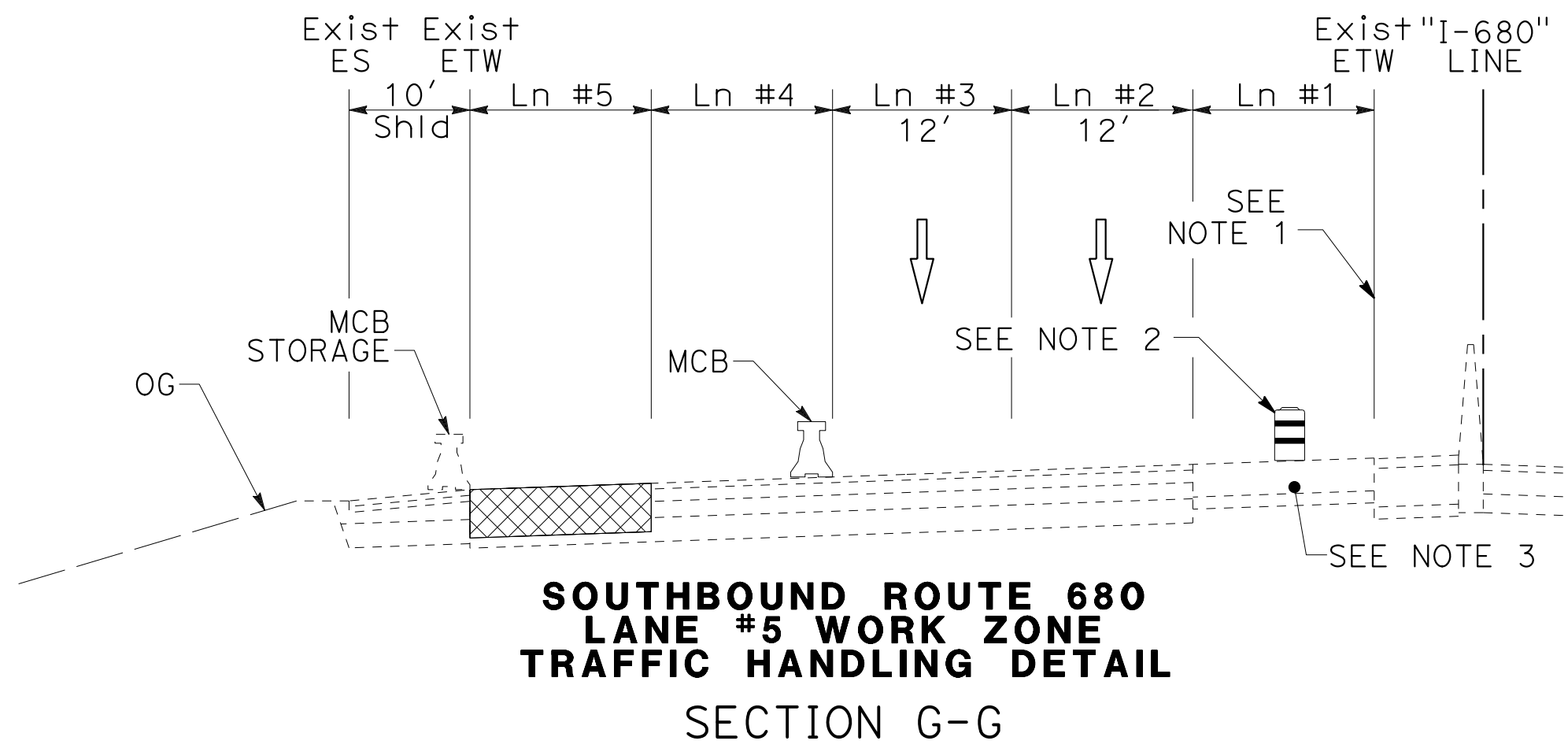

**SOUTHBOUND ROUTE 680
LANE #5 WORK ZONE
TRAFFIC HANDLING DETAIL
SECTION G-G**

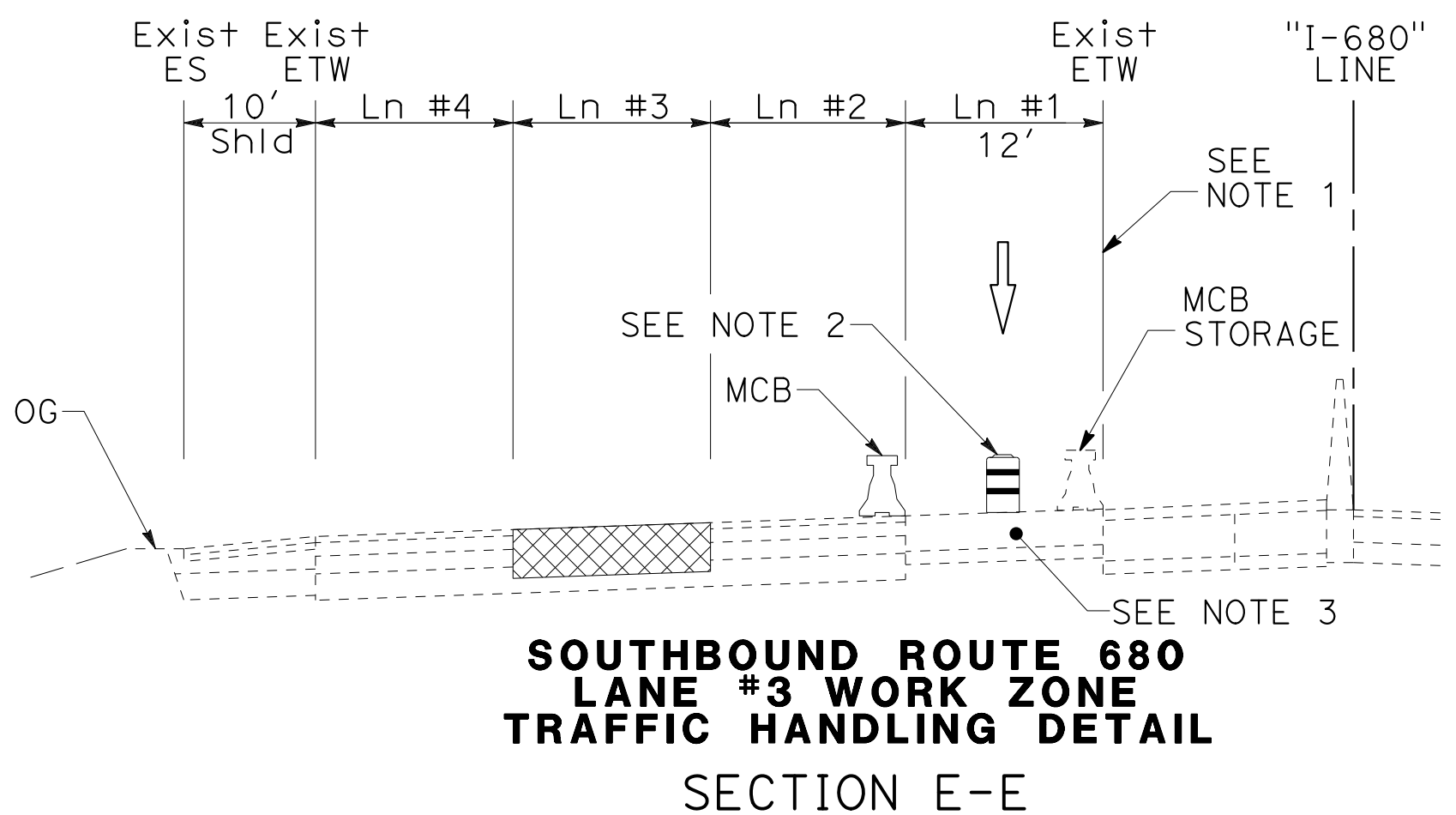

**SOUTHBOUND ROUTE 680
LANE #3 WORK ZONE
TRAFFIC HANDLING DETAIL
SECTION E-E**

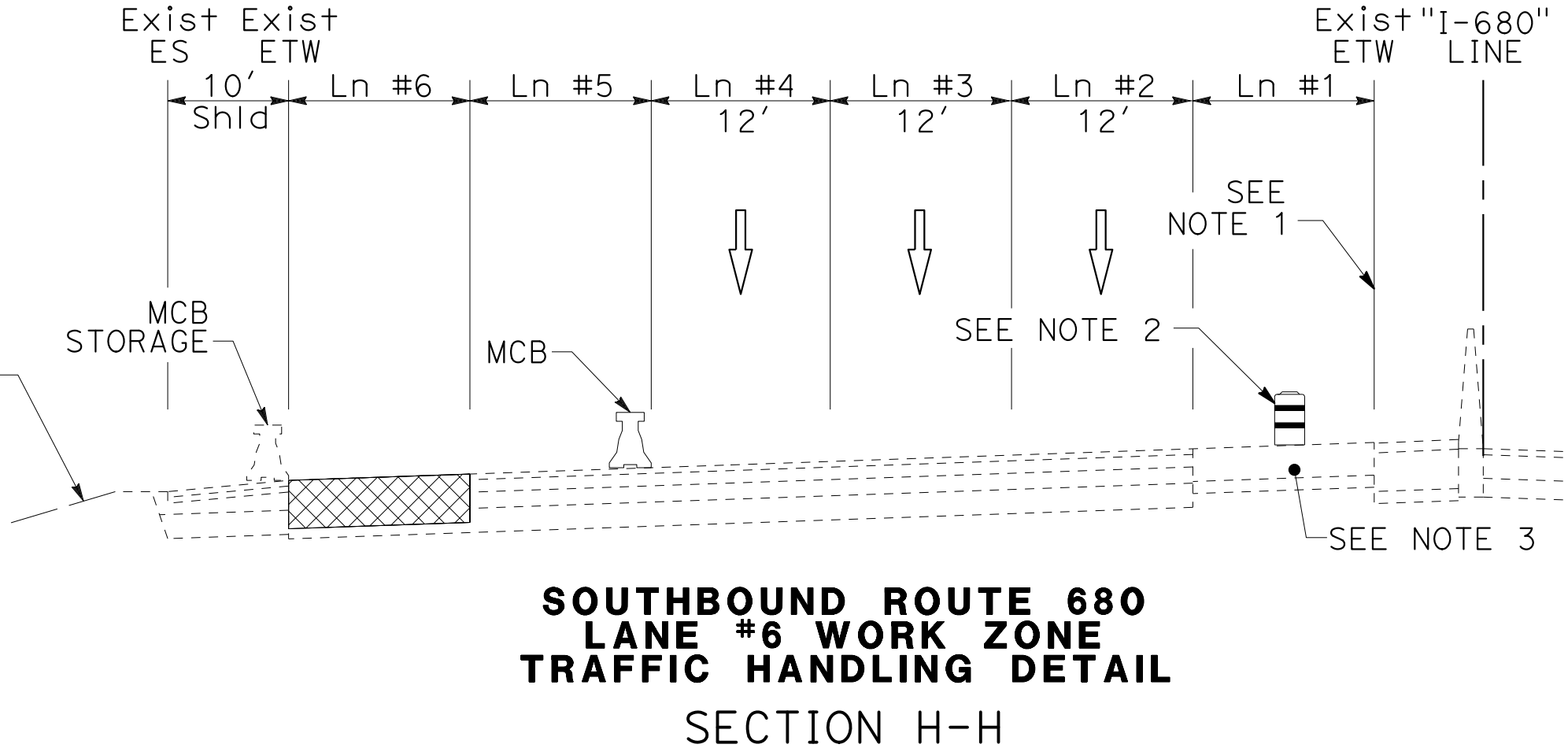

**SOUTHBOUND ROUTE 680
LANE #6 WORK ZONE
TRAFFIC HANDLING DETAIL
SECTION H-H**

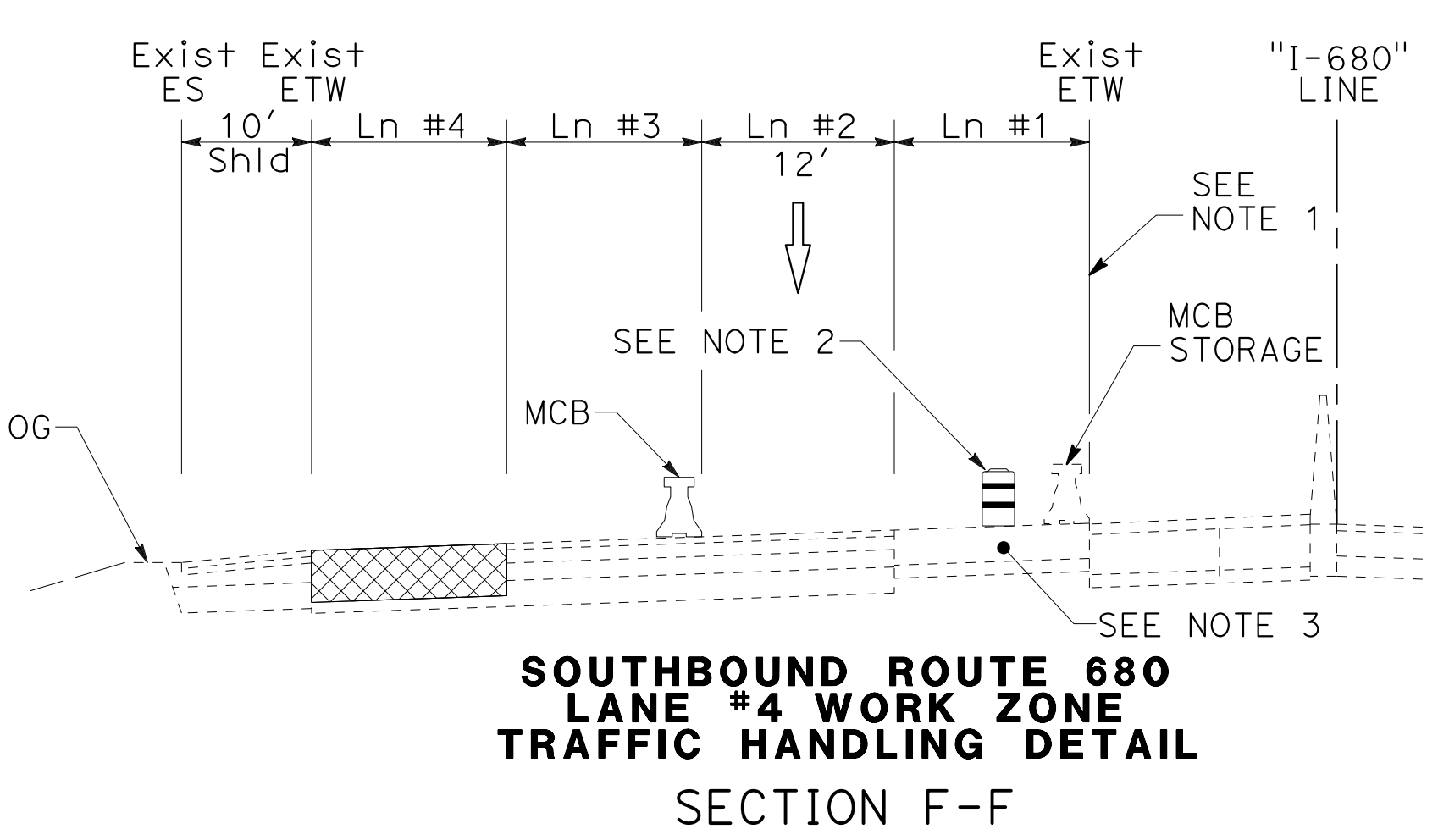

**SOUTHBOUND ROUTE 680
LANE #4 WORK ZONE
TRAFFIC HANDLING DETAIL
SECTION F-F**

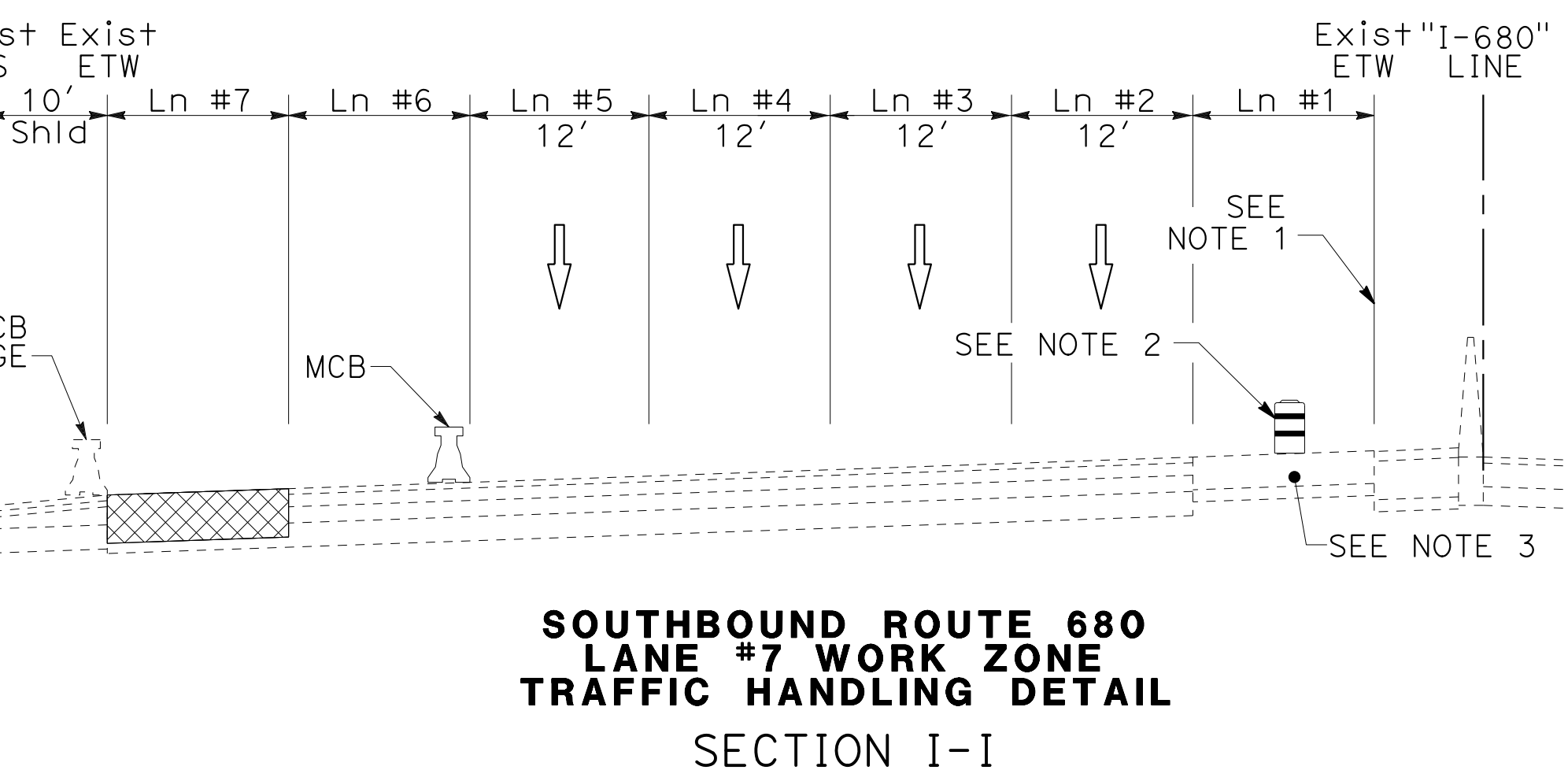

**SOUTHBOUND ROUTE 680
LANE #7 WORK ZONE
TRAFFIC HANDLING DETAIL
SECTION I-I**

**WORK ZONE AND MCB LOCATIONS
FOR 5-LANE TRAVELLED WAY**

LOCATION OF WORK ZONE	LOCATION OF MCB STORAGE	LOCATION OF MCB DURING WORK	No. OF LATERAL SHIFTS (LANES)	LANES OPEN TO TRAFFIC
LANE #2	LANE #1	LANE #3	2	#4,#5
LANE #3	LANE #1	LANE #2	1	#1
LANE #4	LANE #1	LANE #3	2	#1,#2
LANE #5	OUTSIDE Shld	LANE #4	2	#1,#2,#3

**WORK ZONE AND MCB LOCATIONS
FOR 6-LANE TRAVELLED WAY**

LOCATION OF WORK ZONE	LOCATION OF MCB STORAGE	LOCATION OF MCB DURING WORK	No. OF LATERAL SHIFTS (LANES)	LANES OPEN TO TRAFFIC
LANE #2	LANE #1	LANE #3	2	#4,#5,#6
LANE #3	LANE #1	LANE #2	1	#1
LANE #4	LANE #1	LANE #3	2	#1,#2
LANE #5	OUTSIDE Shld	LANE #4	3	#1,#2,#3
LANE #6	OUTSIDE Shld	LANE #5	2	#1, #2,#3,#4

**WORK ZONE AND MCB LOCATIONS
FOR 7-LANE TRAVELLED WAY**



LOCATION OF WORK ZONE	LOCATION OF MCB STORAGE	LOCATION OF MCB DURING WORK	No. OF LATERAL SHIFTS (LANES)	LANES OPEN TO TRAFFIC
LANE #2	LANE #1	LANE #3	2	#4,#5,#6,#7
LANE #3	LANE #1	LANE #2	1	#1
LANE #4	LANE #1	LANE #3	2	#1,#2
LANE #5	LANE #1	LANE #4	3	#1,#2,#3
LANE #6	OUTSIDE Shld	LANE #5	3	#1,#2,#3,#4
LANE #7	OUTSIDE Shld	LANE #6	2	#1,#2,#3,#4,#5

STAGE CONSTRUCTION DETAILS

NO SCALE

SCD-5

01:\0030\UDRAFT\ING\FINAL_P58E\0420000235mb005.dgn
 STATE OF CALIFORNIA - DEPARTMENT OF TRANSPORTATION
 Ervin
 JAMES VALDIVIA
 ERIN McPHERSON
 TIMOTHY J. LEE
 USERNAME => p302438
 DGN FILE => 0420000235mb005.dgn

Dist	COUNTY	ROUTE	POST MILES TOTAL PROJECT	SHEET No.	TOTAL SHEETS
04	Ala, CC	680	R11.0/R21.9, RO.0/RO.9	771	1710
 REGISTERED CIVIL ENGINEER			9-29-21	DATE	
October 8, 2021 PLANS APPROVAL DATE					
<small>THE STATE OF CALIFORNIA OR ITS OFFICERS OR AGENTS SHALL NOT BE RESPONSIBLE FOR THE ACCURACY OR COMPLETENESS OF SCANNED COPIES OF THIS PLAN SHEET.</small>			WMH CORPORATION 55 South Market St Suite 1200 San Jose, CA 95113		
			ALAMEDA CTC 1111 Broadway Suite 800 Oakland, CA 94607		







NOTES:

- FOR ACCURATE RIGHT OF WAY DATA, CONTACT RIGHT OF WAY ENGINEERING AT THE DISTRICT OFFICE.
- REFER TO CALTRANS STANDARD PLANS FOR TRAFFIC CONTROL SYSTEM FOR LANE CLOSURE ON FREEWAYS AND RAMPS.

ABBREVIATION:

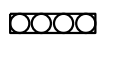
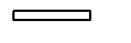
MCB MOVABLE CONCRETE BARRIER

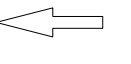
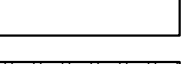
LEGEND:

-  TRAFFIC CONES FOR CLOSURE
-  CHANNELIZERS (SURFACE MOUNTED)
-  Temp Ait CRASH CUSHION
-  K-RAIL
-  TRAFFIC DRUM
-  DIRECTION OF TRAFFIC
-  CONTRACTOR'S AREA
-  WORK ZONE

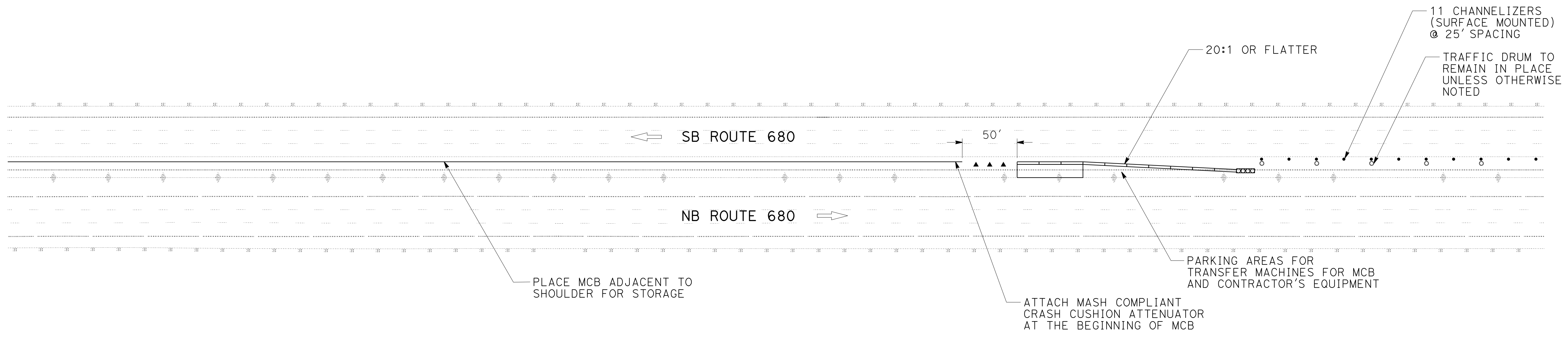

**STAGE CONSTRUCTION DETAILS
MOVABLE BARRIER (STORAGE)
NO SCALE **SCD-6****

O:\0030\DRAWING\FINAL_P5&E\0420000235mb006.dgn
 STATE OF CALIFORNIA - DEPARTMENT OF TRANSPORTATION

 CONSULTANT: JAMES VALDIVIA
 SUPERVISOR: TIMOTHY J. LEE
 CHECKED BY: ERIN McPHERSON
 DESIGNED BY: ERIN McPHERSON
 REVISED BY: JR
 DATE REVISED: 9-29-21

LAST REVISION DATE PLOTTED => 7-MAR-2022 TIME PLOTTED => 12:01
 09-29-21

Dist	COUNTY	ROUTE	POST MILES TOTAL PROJECT	SHEET No.	TOTAL SHEETS
04	Ala, CC	680	R11.0/R21.9, R0.0/R0.9	772	1710

<i>Erin D. McPherson</i>	9-29-21
REGISTERED CIVIL ENGINEER	DATE
October 8, 2021	
PLANS APPROVAL DATE	

THE STATE OF CALIFORNIA OR ITS OFFICERS OR AGENTS SHALL NOT BE RESPONSIBLE FOR THE ACCURACY OR COMPLETENESS OF SCANNED COPIES OF THIS PLAN SHEET.	
---	--

WMH CORPORATION 55 South Market St Suite 1200 San Jose, CA 95113	ALAMEDA CTC 1111 Broadway Suite 800 Oakland, CA 94607
---	--

NOTES:

1. FOR ACCURATE RIGHT OF WAY DATA, CONTACT RIGHT OF WAY ENGINEERING AT THE DISTRICT OFFICE.
2. REFER TO CALTRANS STANDARD PLANS FOR TRAFFIC CONTROL SYSTEM FOR LANE CLOSURE ON FREEWAYS AND RAMPS.

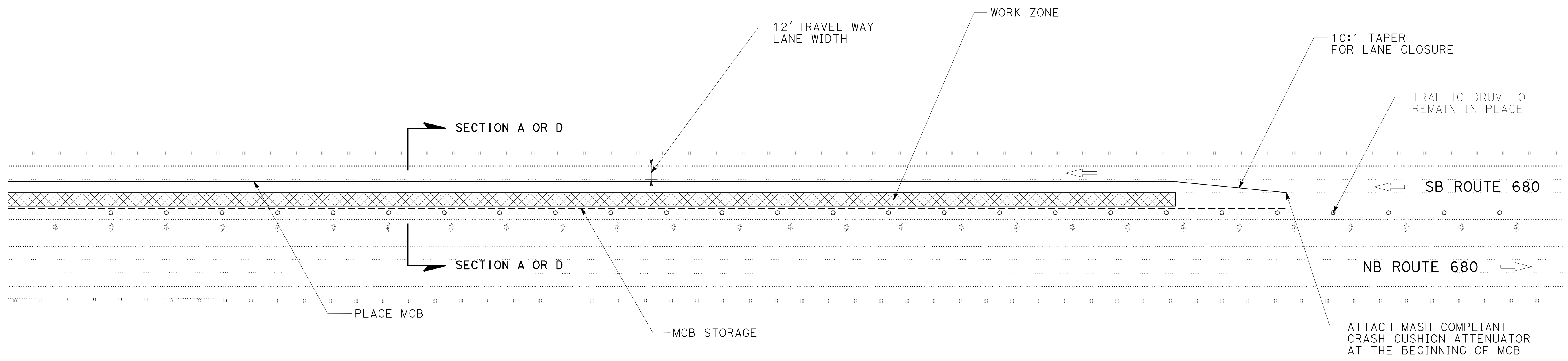

STAGE CONSTRUCTION DETAILS
MOVABLE CONCRETE BARRIER (MCB)
 NO SCALE **SCD-7**

FOR ABBREVIATION AND LEGEND, SEE SHEET SCD-6

0:\0030\UDRAFT\ING\FINAL_P58E\0420000235mb007.dgn
 STATE OF CALIFORNIA - DEPARTMENT OF TRANSPORTATION

BORDER LAST REVISED 7/2/2010

USERNAME => p302438
 DGN FILE => 0420000235mb007.dgn

RELATIVE BORDER SCALE IS IN INCHES

UNIT 0733

PROJECT NUMBER & PHASE

04200002351

LAST REVISION DATE PLOTTED => 7-MAR-2022
 09-29-21 TIME PLOTTED => 12:01

Dist	COUNTY	ROUTE	POST MILES TOTAL PROJECT	SHEET No.	TOTAL SHEETS
04	Ala, CC	680	R11.0/R21.9, RO.0/RO.9	773	1710

<i>Erin D. McPherson</i>	9-29-21
REGISTERED CIVIL ENGINEER	DATE
October 8, 2021	
PLANS APPROVAL DATE	

REGISTERED PROFESSIONAL ENGINEER
ERIN D. McPHERSON
 No. C91111
 Exp. 3-31-24
 CIVIL
 STATE OF CALIFORNIA

THE STATE OF CALIFORNIA OR ITS OFFICERS OR AGENTS SHALL NOT BE RESPONSIBLE FOR THE ACCURACY OR COMPLETENESS OF SCANNED COPIES OF THIS PLAN SHEET.

WMH CORPORATION 55 South Market St Suite 1200 San Jose, CA 95113	ALAMEDA CTC 1111 Broadway Suite 800 Oakland, CA 94607
---	--

NOTES:

- FOR ACCURATE RIGHT OF WAY DATA, CONTACT RIGHT OF WAY ENGINEERING AT THE DISTRICT OFFICE.
- REFER TO CALTRANS STANDARD PLANS FOR TRAFFIC CONTROL SYSTEM FOR LANE CLOSURE ON FREEWAYS AND RAMPS.

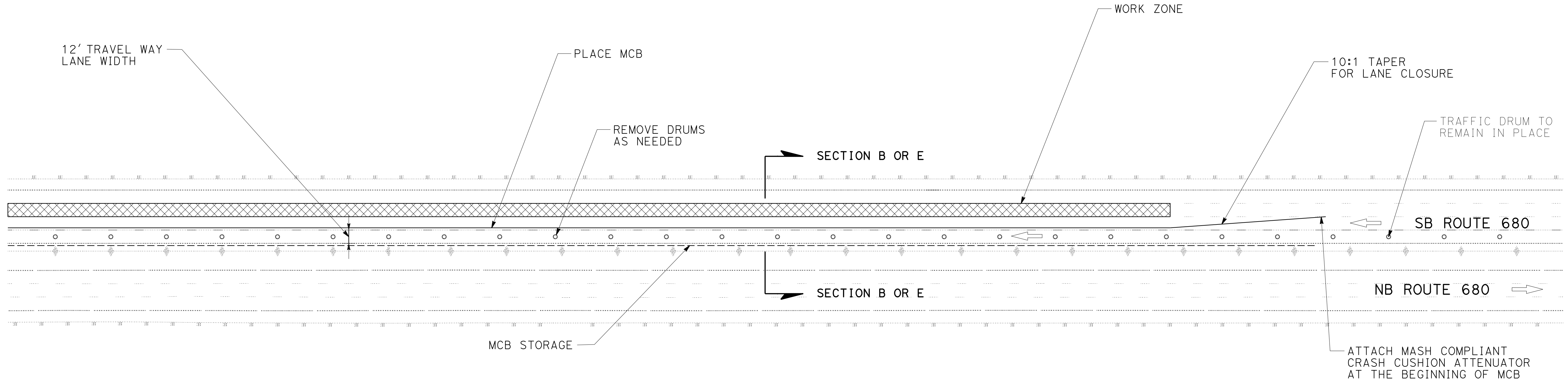

**STAGE CONSTRUCTION DETAILS
MOVABLE CONCRETE BARRIER (MCB)**

NO SCALE **SCD-8**

FOR ABBREVIATION AND LEGEND, SEE SHEET SCD-6

O:\0030\UDRAFT\ING\FINAL_P58E\0420000235mb008.dgn
 STATE OF CALIFORNIA - DEPARTMENT OF TRANSPORTATION

Dist	COUNTY	ROUTE	POST MILES TOTAL PROJECT	SHEET No.	TOTAL SHEETS
04	Ala, CC	680	R11.0/R21.9, R0.0/R0.9	774	1710

<i>Erin D. McPherson</i>	9-29-21
REGISTERED CIVIL ENGINEER	DATE
October 8, 2021	
PLANS APPROVAL DATE	

REGISTERED PROFESSIONAL ENGINEER
ERIN D. McPHERSON
 No. C91111
 Exp. 3-31-24
 CIVIL
 STATE OF CALIFORNIA

THE STATE OF CALIFORNIA OR ITS OFFICERS OR AGENTS SHALL NOT BE RESPONSIBLE FOR THE ACCURACY OR COMPLETENESS OF SCANNED COPIES OF THIS PLAN SHEET.

WMH CORPORATION 55 South Market St Suite 1200 San Jose, CA 95113	ALAMEDA CTC 1111 Broadway Suite 800 Oakland, CA 94607
---	--

NOTES:

- FOR ACCURATE RIGHT OF WAY DATA, CONTACT RIGHT OF WAY ENGINEERING AT THE DISTRICT OFFICE.
- REFER TO CALTRANS STANDARD PLANS FOR TRAFFIC CONTROL SYSTEM FOR LANE CLOSURE ON FREEWAYS AND RAMPS.

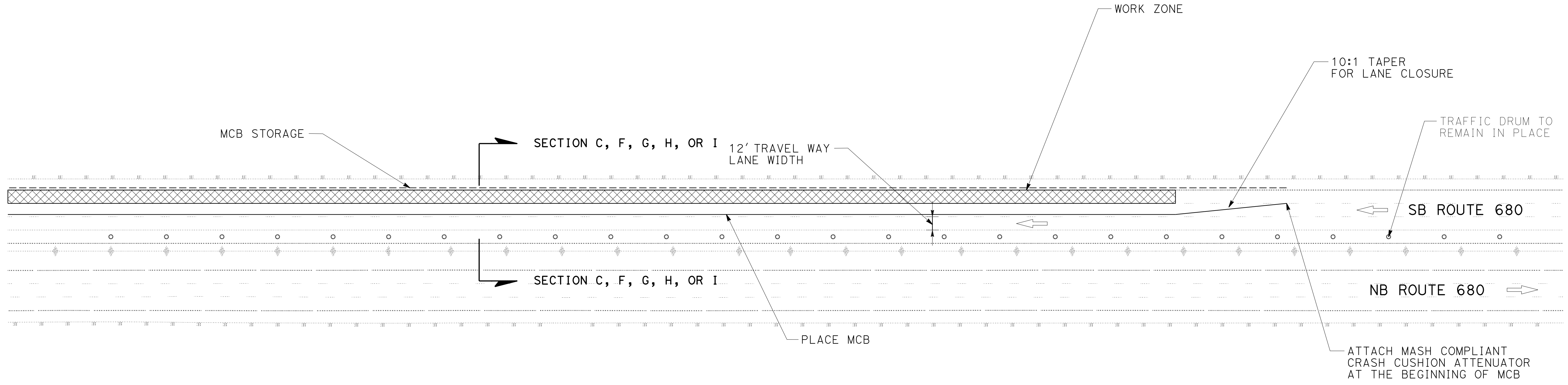

O:\0030\UDRAFT\ING\FINAL_P58E\0420000235mb009.dgn
 STATE OF CALIFORNIA - DEPARTMENT OF TRANSPORTATION
 Et Caltrans®
 CONSULTANT FUNCTIONAL SUPERVISOR: TIMOTHY J. LEE
 CALCULATED/DESIGNED BY: JAMEY VALDIVIA
 CHECKED BY: ERIN McPHERSON
 REVISED BY: JR
 DATE REVISED: 9-29-21

FOR ABBREVIATION AND LEGEND, SEE SHEET SCD-6

STAGE CONSTRUCTION DETAILS
MOVABLE CONCRETE BARRIER (MCB)
 NO SCALE **SCD-9**

LAST REVISION: 09-29-21 DATE PLOTTED => 7-MAR-2022 TIME PLOTTED => 12:01

Dist	COUNTY	ROUTE	POST MILES TOTAL PROJECT	SHEET No.	TOTAL SHEETS
04	Ala, CC	680	R11.0/R21.9, RO.0/RO.9	775	1710
			9-29-21		
REGISTERED CIVIL ENGINEER			DATE		
October 8, 2021			PLANS APPROVAL DATE		
WMH CORPORATION 55 South Market St Suite 1200 San Jose, CA 95113			ALAMEDA CTC 1111 Broadway Suite 800 Oakland, CA 94607		

NOTES:

- FOR ACCURATE RIGHT OF WAY DATA, CONTACT RIGHT OF WAY ENGINEERING AT THE DISTRICT OFFICE.
- REFER TO CALTRANS STANDARD PLANS FOR TRAFFIC CONTROL SYSTEM FOR LANE CLOSURE ON FREEWAYS AND RAMPS.

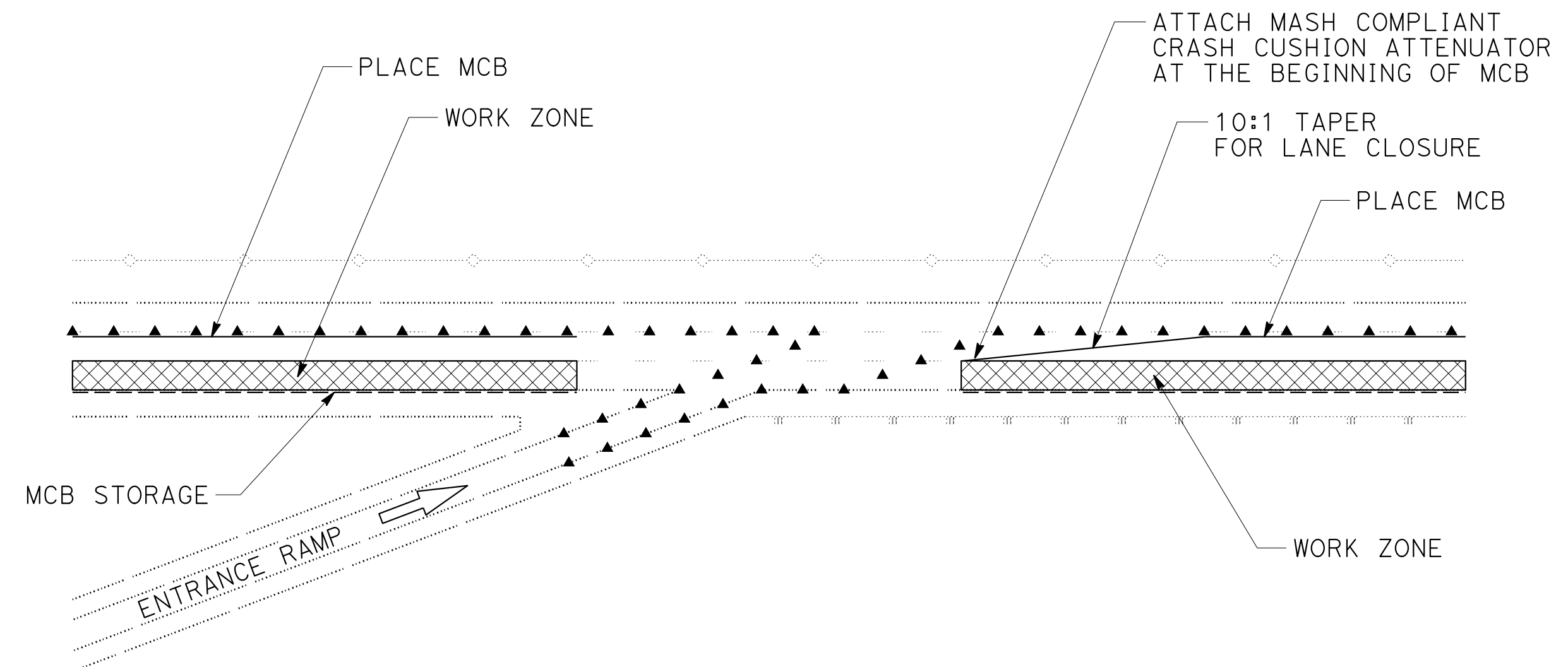

**LANE CLOSURE AT ENTRANCE RAMP
(WORK AREA NEAR THE RAMP)**

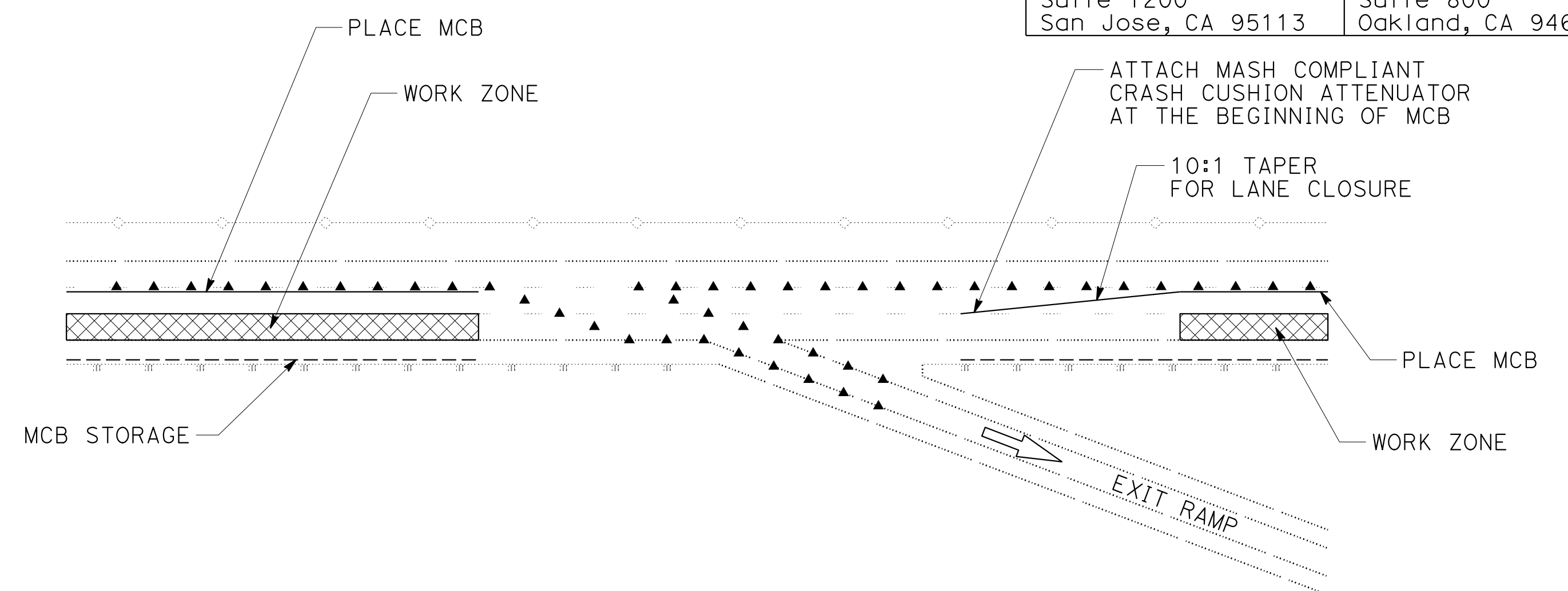

**LANE CLOSURE AT EXIT RAMP
(WORK AREA NEAR THE RAMP)**

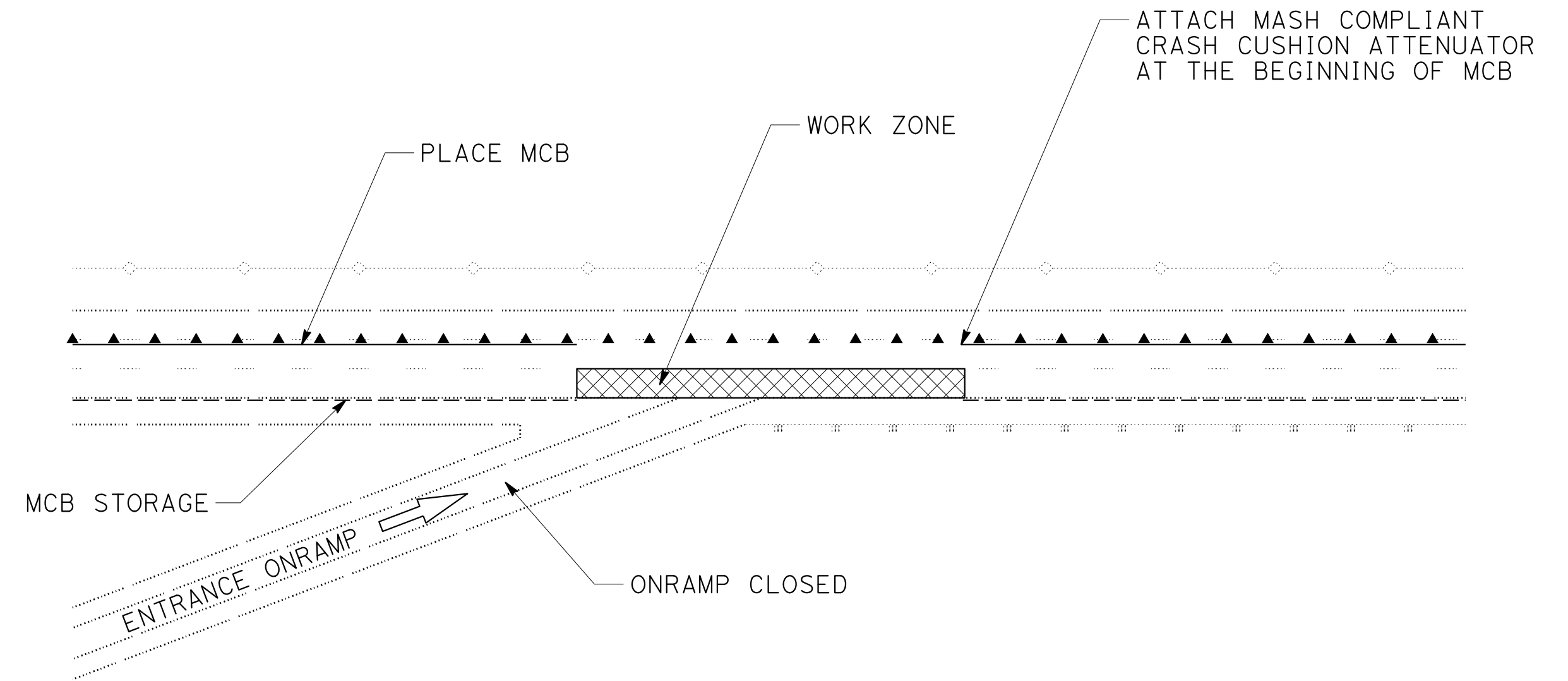

**LANE CLOSURE AT ENTRANCE RAMP
(WORK AREA AT THE RAMP)**

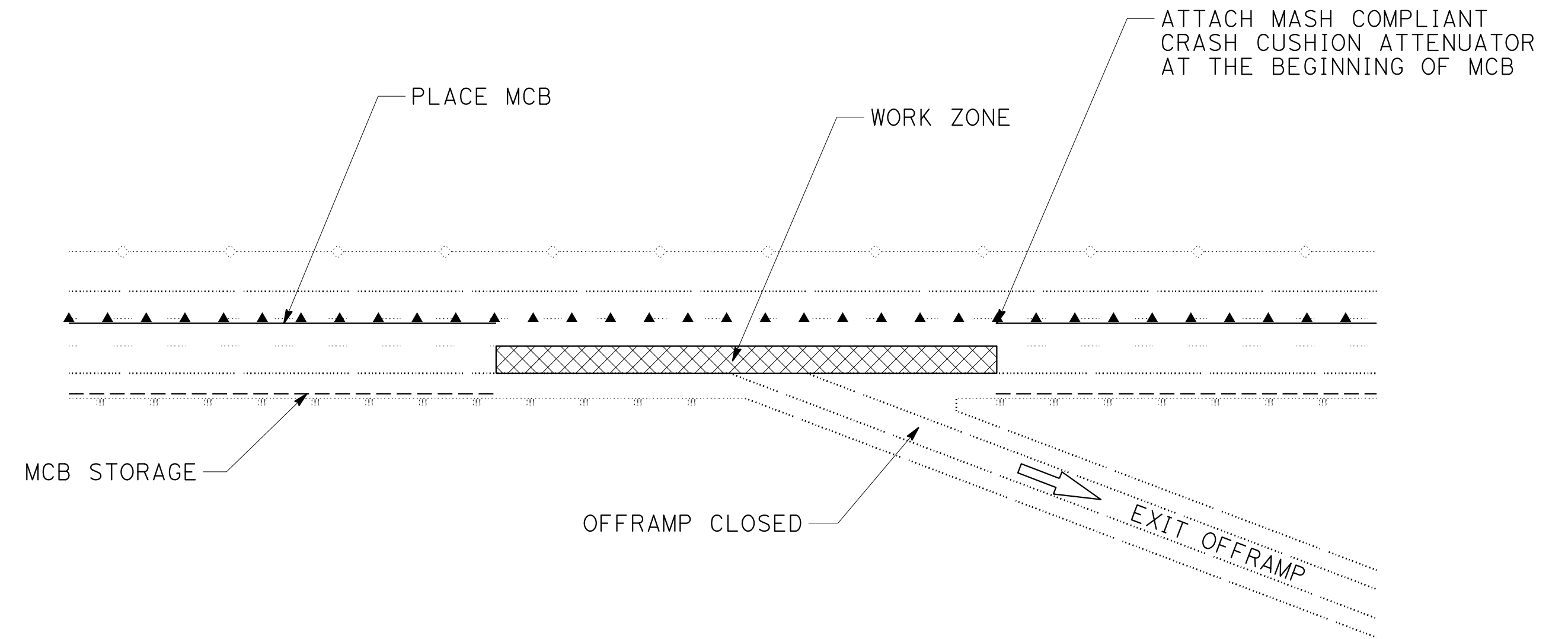

**LANE CLOSURE AT EXIT RAMP
(WORK AREA AT THE RAMP)**

**STAGE CONSTRUCTION DETAILS
MOVABLE CONCRETE BARRIER (MCB)
NO SCALE **SCD-10****

FOR ABBREVIATION AND LEGEND, SEE SHEET SCD-6

0:\0030\UDRAFT\ING\FINAL_P58E\0420000235mb010.dgn
 STATE OF CALIFORNIA - DEPARTMENT OF TRANSPORTATION
 ERIN MCPHERSON
 JAMEY VALDIVIA
 JR
 9-29-21
 REVISOR
 DATE
 CHECKED BY
 SUPERVISOR
 TIMOTHY J. LEE
 CONSULTANT
 FUNCTIONAL SUPERVISOR
 DESIGNED BY
 CALCULATED BY
 CHECKED BY
 DESIGNED BY
 CALCULATED BY
 CHECKED BY
 DESIGNED BY
 CALCULATED BY
 CHECKED BY

TEMPORARY TRAFFIC CONTROL DEVICES

STAGE	STATION					TEMPORARY BARRIER SYSTEM	ALTERNATIVE TEMPORARY CRASH CUSHION	CHANNELIZER (SURFACE MOUNTED)	PLASTIC TRAFFIC DRUMS	TEMPORARY FENCE (TYPE CL-6)	TYPE III BARRICADE	COLD PLANE ASPHALT CONCRETE PAVEMENT	HMA (TYPE A)
						TEMPORARY RAILING (TYPE K)							
						LF	EA	EA	EA	LF	EA	SQYD	TON
STAGE 1 PHASE 2B	"I-680"	158+50	TO	"I-680"	161+00			6					
	"I-680"	161+71	TO				1						
	"I-680"	161+71	TO	"I-680"	174+12	1,260							
	"I-680"	201+00	TO	"I-680"	203+50			6					
	"I-680"	204+17	TO				1						
STAGE 2	"I-680"	204+17	TO	"I-680"	297+29	9,300							
	"I-680"	203+50	TO	"I-680"	341+50				278				
	"I-680"	336+00	TO	"I-680"	371+77	3,580							
	"I-680"	371+77	TO										
	"I-680"	375+30	TO	"I-680"	378+69	340							
	"I-680"	378+69	TO										
	"I-680"	375+30	TO	"I-680"	393+90	1,860							
	"I-680"	393+90	TO										
	"SBO"	389+36	TO	"I-680"	511+27	12,200							
	"I-680"	511+27	TO										
	"I-680"	428+64	TO	"I-680"	453+68				51				
	"ER"	512+00	TO	"ER"	514+00			5					
	"I-680"	515+35	TO	"I-680"	535+38	2,000							
	"I-680"	535+38	TO										
	"I-680"	509+00	TO	"I-680"	685+00				352				
	"I-680"	551+58	TO	"ESB"	564+13	1,240							
	"ESB"	564+13	TO										
	"DBV"	572+42	TO	"DBV"	578+22	560							
	"DBV"	578+22	TO										
	"SAB"	651+14	TO	"SAB"	658+36	720							
	"SAB"	658+36	TO										
	"I-680"	658+66	TO										
	"I-680"	658+66	TO	"SAB"	659+15	140							
"SAB"	659+15	TO											
"I-680"	659+35	TO											
"I-680"	659+35	TO	"SAB"	660+30	200								
"I-680"	660+28	TO	"I-680"	662+49	220								
STAGE 3	"I-680"	162+00	TO	"I-680"	685+00				1,047				
	"I-680"	398+00	TO							2			
	"SBD"	575+00	TO							2			
STAGE 4	"SKP"	161+50	TO										
	"SKP"	161+50	TO	"I-680"	303+31	14,240							
	"I-680"	303+31	TO										
	"I-680"	161+34	TO	"I-680"	174+78	1,300							
	"I-680"	174+78	TO										
	"I-680"	203+00	TO	"I-680"	210+50				17				
	"I-680"	238+00	TO	"I-680"	244+50				13				
	"I-680"	282+55	TO	"I-680"	295+00				25				
	"I-680"	303+30	TO	"SS"	306+00								
	"I-680"	303+91	TO	"I-680"	322+40	1,820							
	"I-680"	322+40	TO										
	"SS"	310+13	TO	"SS"	317+87	720							
	"SS"	317+87	TO										
	"SS"	317+87	TO	"SS"	319+00								
	"ST"	308+72	TO										
	"ST"	308+72	TO	"I-680"	349+77	4,160							
"I-680"	355+90	TO	"I-680"	570+85				427					
"I-680"	535+77	TO	"ESB"	554+18	1,860								
"ESB"	554+18	TO											
SHEET SCQ-2 TOTAL						57,720	20	25	2,210		4		

Dist	COUNTY	ROUTE	POST MILES TOTAL PROJECT	SHEET No.	TOTAL SHEETS
04	Ala, CC	680	R11.0/R21.9, RO.0/RO.9	777	1710
ERIN D. McPHERSON REGISTERED CIVIL ENGINEER			9-29-21	DATE	
October 8, 2021 PLANS APPROVAL DATE					
THE STATE OF CALIFORNIA OR ITS OFFICERS OR AGENTS SHALL NOT BE RESPONSIBLE FOR THE ACCURACY OR COMPLETENESS OF SCANNED COPIES OF THIS PLAN SHEET.					
WMH CORPORATION 55 South Market St Suite 1200 San Jose, CA 95113			ALAMEDA CTC 1111 Broadway Suite 800 Oakland, CA 94607		

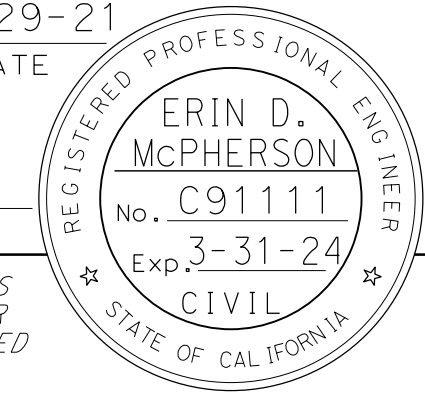

STAGE CONSTRUCTION AND TRAFFIC HANDLING QUANTITIES SCQ-2

X:\680_SB_GAP_EXPRESS\000_CAD\Submittal\11\11\CADD_submittal\0420000235mc003.dgn
 STATE OF CALIFORNIA - DEPARTMENT OF TRANSPORTATION
 CONSULTANT FUNCTIONAL SUPERVISOR
 JAMEY VALDIVIA
 ERIN McPHERSON
 CALCULATED-DESIGNED BY
 CHECKED BY
 TIMOTHY J. LEE

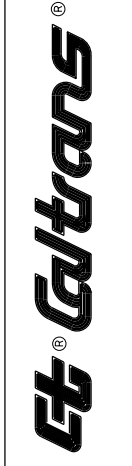

TEMPORARY TRAFFIC CONTROL DEVICES

STAGE	STATION						TEMPORARY BARRIER SYSTEM	ALTERNATIVE TEMPORARY CRASH CUSHION	CHANNELIZER (SURFACE MOUNTED)	PLASTIC TRAFFIC DRUMS	TEMPORARY FENCE (TYPE CL-6)	TYPE III BARRICADE	COLD PLANE ASPHALT CONCRETE PAVEMENT	HMA (TYPE A)
							TEMPORARY RAILING (TYPE K)	EA	EA	EA	LF	EA	SQYD	TON
							LF	EA	EA	EA	LF	EA	SQYD	TON
STAGE 4	"I-680"	557+76	TO	"I-680"	563+68	SB								
	"I-680"	563+68	TO	"SDB"	568+56	SB	500							
	"SDB"	568+56	TO			SB		1						
	"I-680"	563+68	TO	"I-680"	581+09	SB	1,740							
STAGE 5	"I-680"	581+09	TO			SB		1						
	"SKP"	160+74	TO			SB		1						
	"SKP"	160+74	TO	"SKP"	172+99	SB	1,180							
	"SKP"	172+99	TO			SB		1						
	"SS"	310+22	TO	"TS"	316+95	SB	660							
	"TS"	316+95	TO			SB		1						
	"TS"	317+07	TO			SB		1						
	"TS"	317+07	TO	"SS"	317+00	SB	280							
	"SS"	317+58	TO			SB		1						
	"ST"	309+04	TO	"ST"	318+83	SB	980							
	"ST"	318+83	TO			SB		1						
	"I-680"	523+59	TO			SB		1						
	"I-680"	523+59	TO	"I-680"	525+67	SB	580							
	"ESB"	554+66	TO	"ESB"	563+09	SB	840							
	"ESB"	563+09	TO			SB		1						
	"I-680"	554+46	TO	"I-680"	560+45	SB	600							
"I-680"	560+45	TO			SB		1							
"WSL"	563+76	TO	"WSL"	571+33	SB									
"WSL"	571+33	TO			SB		1							
SHEET SCQ-3 TOTAL							7,360	12	24					
SHEET SCQ-2 TOTAL							57,720	20	25	2,210		4		
SHEET SCQ-1 TOTAL							100,620	9	21		4,424		20,806	7,022
FROM MOVABLE CONCRETE BARRIER							196	14	2,800					
GRAND TOTAL							165,896	55	2,870	2,210	4,424	4	20,806 *	7,022 *

(*) - QUANTITIES INCLUDED IN SUMMARY OF QUANTITIES SHEETS.

Dist	COUNTY	ROUTE	POST MILES TOTAL PROJECT	SHEET No.	TOTAL SHEETS
04	Ala, CC	680	R11.0/R21.9, RO.0/RO.9	778	1710
			9-29-21		
REGISTERED CIVIL ENGINEER			DATE		
October 8, 2021					
PLANS APPROVAL DATE					
THE STATE OF CALIFORNIA OR ITS OFFICERS OR AGENTS SHALL NOT BE RESPONSIBLE FOR THE ACCURACY OR COMPLETENESS OF SCANNED COPIES OF THIS PLAN SHEET.					
WMH CORPORATION 55 South Market St Suite 1200 San Jose, CA 95113			ALAMEDA CTC 1111 Broadway Suite 800 Oakland, CA 94607		

STAGE CONSTRUCTION AND TRAFFIC HANDLING QUANTITIES

SCQ-3

LAST REVISION DATE PLOTTED => 3/28/2022 09-29-21 TIME PLOTTED => 2:57:20 PM

TEMPORARY PAVEMENT DELINEATION

Dist	COUNTY	ROUTE	POST MILES TOTAL PROJECT	SHEET No.	TOTAL SHEETS
04	Ala, CC	680	R11.0/R21.9, RO.0/RO.9	788	1710
REGISTERED CIVIL ENGINEER			9-29-21 DATE		
October 8, 2021 PLANS APPROVAL DATE					
WMH CORPORATION 55 South Market St Suite 1200 San Jose, CA 95113			ALAMEDA CTC 1111 Broadway Suite 800 Oakland, CA 94607		

SHEET No.	STAGE No.	STATION	DETAIL No.	LENGTH (N)	TEMPORARY TRAFFIC STRIPE (PAINT)				CONTRAST STRIPE PAINT (1-COAT)				TEMPORARY PAVEMENT MARKER				REMOVE THERMOPLASTIC TRAFFIC STRIPE	REMOVE YELLOW THERMOPLASTIC TRAFFIC STRIPE (HAZARDOUS WASTE)	REMOVE PAVEMENT MARKER	REMOVE THERMOPLASTIC PAVEMENT MARKING		
					6"		YELLOW	8"		6"		YELLOW	8"		RETROREFLECTIVE							
					BROKEN (17-7)	BROKEN (18-12)		WHITE	SOLID	BROKEN (17-7)	BROKEN (18-12)		SOLID	SOLID	BROKEN (12-3)	SOLID					TYPE	
					RY	R	G	C	EA	EA	SQFT	EA	SQFT	EA	SQFT	EA					SQFT	
SC-204		"I-680" 412+65 TO 544+03 SB 12A	26,276																549			
SC-211		"ER" 509+24 TO 511+95 SB 9A	271																7			
SC-211		"ER" 511+95 TO 514+91 SB 36A	296																			
SC-211		"I-680" 511+95 TO 513+76 SB 36A	181																			
SC-212		"I-680" 523+02 TO 525+14 SB 36A	212																			
SC-212		"I-680" 525+14 TO 530+00 SB 27B	486			486																
SC-212		"SR" 530+00 TO 536+16 SB 36	616																27			
SC-212		"I-680" 535+34 TO 536+16 SB 36	82																5			
SC-212		"I-680" 535+34 TO 537+58 SB 38B	224																22			
SC-213		"I-680" 535+77 TO 554+03 SB 27B	1,826			1,826																
SC-213		"I-680" 537+58 TO 544+03 SB 37	645					645											46			
SC-213		"I-680" 544+03 TO 549+71 SB 37S	568					568														
SC-213	STAGE 4	"I-680" 544+03 TO 584+00 SB 12AS	7,994			7,994				7,994									168			
SC-214		"I-680" 549+71 TO 554+70 SB 36A	499							499												
SC-214		"I-680" 554+70 TO 556+24 SB 25	154				154															
SC-214		"I-680" 550+21 TO 552+26 SB 36A	205							205												
SC-214		"I-680" 552+26 TO 561+27 SB 27BS	901							901												
SC-214		"ESB" 553+26 TO 554+03 SB 9A	77																3			
SC-214		"ESB" 554+03 TO 561+41 SB 25	738				738												17			
SC-214		"I-680" 557+76 TO 563+68 SB 27BS	592							592												
SC-215		"I-680" 563+68 TO 581+21 SB 27BS	1,753							1,753												
SC-216		"I-680" 580+51 TO 584+00 SB 12AS	349			349				349									9			
SC-216		"SCN" 581+21 TO 584+40 SB 36S	319																			
SC-216		"I-680" 584+40 TO 587+39 SB 38S	299																14			
SC-216		"I-680" 581+21 TO 584+40 SB 36S	319																			
SC-226		"SKP" 161+63 TO 179+19 SB 27B	1,756																			
SC-226		"SKP" 161+67 TO 174+38 SB 25A	1,271																			
SC-227		"SKP" 174+38 TO 177+75 SB 36	337																16			
SC-227		"I-680" 177+29 TO 177+75 SB 36	46																3			
SC-235		"ST" 309+04 TO 323+96 SB 27B	1,492																			
SC-235		"ST" 309+04 TO 318+80 SB 25A	976																			
SC-235	STAGE 5	"SS" 308+40 TO 316+95 SB 25A	855																			
SC-235		"TS" 316+28 TO 317+07 SB 27B	79				79															
SC-235		"SS" 316+19 TO 317+58 SB 25A	139																			
SC-235		"SS" 303+63 TO 318+98 SB 27B	1,535																			
SC-235		"SS" 303+63 TO 308+40 SB 36	477																21			
SC-236		"ST" 318+80 TO 322+55 SB 36	375																17			
SC-236		"I-680" 322+08 TO 322+55 SB 36	47																3			
SC-243	STAGE 5	"ESB" 552+80 TO 554+73 SB 9A	193																6			
SC-243		"ESB" 550+33 TO 565+11 SB 27B	1,478																			
SC-243		"ESB" 554+73 TO 564+52 SB 25	979																			
SHEET SCQ-13 TOTAL					348	34,619	10,420	4,133	1,213	4,534	8,343	3,246	568	638	162	182	14	896				

(N) - NOT A SEPARATE BID ITEM.

STAGE CONSTRUCTION AND TRAFFIC HANDLING QUANTITIES

SCQ-13

Dist	COUNTY	ROUTE	POST MILES TOTAL PROJECT	SHEET No.	TOTAL SHEETS
04	Ala, CC	680	R11.0/R21.9, R0.0/R0.9	790	1710

ERIN D. McPHERSON
 REGISTERED CIVIL ENGINEER
 No. C91111
 Exp. 3-31-24
 CIVIL
 STATE OF CALIFORNIA

9-29-21
 DATE
 REGISTERED CIVIL ENGINEER

October 8, 2021
 PLANS APPROVAL DATE

THE STATE OF CALIFORNIA OR ITS OFFICERS OR AGENTS SHALL NOT BE RESPONSIBLE FOR THE ACCURACY OR COMPLETENESS OF SCANNED COPIES OF THIS PLAN SHEET.

WMH CORPORATION 55 South Market St Suite 1200 San Jose, CA 95113	ALAMEDA CTC 1111 Broadway Suite 800 Oakland, CA 94607
---	--

TEMPORARY PAVEMENT DELINEATION



SHEET No.	STAGE No.	STATION	DETAIL No.	LENGTH (N)	TEMPORARY PAVEMENT MARKING (PAINT)									
					LIMIT LINE	WHITE CHEVRON	TYPE I ARROW	TYPE V ARROW	TYPE VI ARROW	ROUTE SHIELD 580	ROUTE SHIELD 680	"STOP"	"AHEAD"	
					LF	SQFT								
SC-75	STAGE 1	"I-680" 575+93	SB						42					
SC-76	PHASE 2A	"I-680" 578+00	SB						42					
SC-76	PHASE 2A	"I-680" 580+00	SB						42					
SC-126	STAGE 2	"I-680" 511+56	SB						42					
SC-130		"I-680" 576+00	SB						42					
SC-131		"I-680" 578+00	SB						42					
SC-131		"I-680" 580+00	SB						42					
SC-138		"I-680" 679+59	SB						42					
SC-138		"I-680" 682+12	SB						42					
SC-138	"I-680" 684+62	SB						42						
SC-144	STAGE 3	"I-680" 174+38 TO 177+29	SB				147							
SC-154		"I-680" 318+80 TO 322+07	SB				146							
SC-159		"I-680" 389+45 TO 393+07	SB				126							
SC-176	"I-680" 630+00	SB							73	292				
SC-180	"I-680" 679+62	SB						42						
SC-180	"I-680" 682+12	SB						42						
SC-165	STAGE 4	"SKP" 161+76	SB		39									
SC-185		"SKP" 161+76	SB									22		
SC-185		"SKP" 162+02	SB					33						
SC-185		"SKP" 165+87	SB					33						
SC-185		"SKP" 167+87	SB										31	
SC-185		"SKP" 168+39	SB									22		
SC-195		"ST" 309+04	SB	LL	31	31								
SC-195		"ST" 309+18	SB									22		
SC-195		"ST" 309+57	SB											
SC-195		"TS" 316+75	SB				31							
SC-196		"ST" 313+51	SB						33					
SC-196	"ST" 315+64	SB										31		
SC-196	"ST" 316+17	SB									22			
SC-215	STAGE 5	"I-680" 580+54	SB						42					
SC-215		"I-680" 582+29	SB						42					
SC-215		"I-680" 583+78	SB						42					
SC-225	STAGE 5	"SKP" 161+67	SB	LL	39	39								
SC-225		"SKP" 161+74	SB									22		
SC-225		"SKP" 162+02	SB						33					
SC-225		"SKP" 165+88	SB						33					
SC-225		"SKP" 167+88	SB										31	
SC-225		"SKP" 168+39	SB									22		
SC-234		"ST" 309+04	SB	LL	39	39								
SC-234		"ST" 309+18	SB									22		
SC-234		"ST" 309+56	SB							33				
SC-234		"SS" 316+80	SB					62						
SC-234	"SS" 310+74	SB	LL	13	13									
SC-235	"ST" 313+51	SB							33					
SC-235	"ST" 315+64	SB											31	
SC-235	"ST" 316+17	SB									22			
SUBTOTAL					161	419	93	264	630	73	292	176	124	
GRAND TOTAL					2,232									

(N) - NOT A SEPARATE BID ITEM.

STAGE CONSTRUCTION AND TRAFFIC HANDLING QUANTITIES

SCQ-15

CONSTRUCTION AREA SIGNS (STATIONARY MOUNTED)

Dist	COUNTY	ROUTE	POST MILES TOTAL PROJECT	SHEET No.	TOTAL SHEETS
04	Ala, CC	680	R11.0/R21.9, RO.0/RO.9	791	1710
 REGISTERED CIVIL ENGINEER			9-29-21	DATE	
October 8, 2021 PLANS APPROVAL DATE					
WMH CORPORATION 55 South Market St Suite 1200 San Jose, CA 95113			ALAMEDA CTC 1111 Broadway Suite 800 Oakland, CA 94607		

STAGE No.	DESIGNATION	SIGN MESSAGE	DESCRIPTION	No. OF POSTS AND SIZE	No. OF SIGNS (N)
STAGE 1 PHASE 2A	G20-3	END ROAD WORK		1 - 4" x 4"	2
	W20-2	ROAD WORK AHEAD		1 - 4" x 6"	9
	W21-5b(L)	LEFT SHOULDER CLOSED AHEAD		1 - 4" x 6"	4
	C30A(CA)	SHOULDER CLOSED	MOUNT WITH C12(CA) - 2 LOCATIONS	2 - 6" x 6"	4
	C12(CA)	NARROW LANE		1 - 4" x 6"	11
	W34C(CA)	CAUTION VERTICAL CLEARANCE ARROW	15' 6"	2 - 4" x 6"	1
	D13-4	FREEWAY ENTRANCE	MOUNT WITH G27-2(CA) MOUNT WITH M3-3 MOUNT WITH M6-2a(Lt)	1 - 4" x 6"	4
	W4-3	LANE ENDS SIGN		1 - 4" x 6"	1
	W9-2	RIGHT LANE ENDS		1 - 4" x 6"	1
	R5-10a	NO PEDESTRIANS BICYCLES MOTOR-DRIVEN CYCLES		1 - 4" x 4"	1
	SC1-1	G23-3(CA)	SEE SIGN DETAIL SC1-1	2 - 6" x 8"	1
	SC1-2	G23-4(CA) Mod	SEE SIGN DETAIL SC1-2	2 - 6" x 8"	1
	SC1-3	E1-5P Mod G86-14(CA) Mod	SEE SIGN DETAIL SC1-3	2 - 6" x 8"	1
	STAGE 1 PHASE 2B	C12(CA)	NARROW LANE		1 - 4" x 6"
STAGE 2	R20-1(CA) Mod	NO TRUCKS	SUNOL BLVD OVER 8 TONS	2 - 4" x 6"	1
	W4-2	MERGE		1 - 4" x 6"	2
	W34C(CA)	CAUTION VERTICAL CLEARANCE ARROW	14' 11"	2 - 4" x 6"	1
	R20-1(CA) Mod	NO TRUCKS	BERNAL AVE OVER 3 TONS	2 - 4" x 6"	1
	M3-4	SOUTH		1 - 4" x 4"	1
	G27-2(CA)	INTERSTATE CALIFORNIA ROUTE MARKER	680	1 - 4" x 4"	1
	G30A(CA)	SCENIC ROUTE		1 - 4" x 4"	1
	G84-2(CA)	EXIT WITH ARROW	29	1 - 4" x 6"	1
	C23(CA)	ROAD WORK AHEAD		1 - 4" x 6"	2
	W21-5b(R)	RIGHT SHOULDER CLOSED AHEAD		1 - 4" x 6"	3
	C30A(CA)	SHOULDER CLOSED	MOUNT WITH C12(CA)	2 - 6" x 6"	2
	W4-3	LANE ENDS SIGN		1 - 4" x 6"	1
	W9-2	RIGHT LANE ENDS		1 - 4" x 6"	1
	C12(CA)	NARROW LANE		1 - 4" x 6"	1
	W20-2	ROAD WORK AHEAD		1 - 4" x 6"	1
	C30(CA)	LANE CLOSED		1 - 4" x 6"	7
	SC2-1	E1-5P Mod G86-1(CA) Mod	SEE SIGN DETAIL SC2-1	2 - 4" x 6"	1
	SC2-2	E1-5P Mod G86-5(CA) Mod	SEE SIGN DETAIL SC2-2	2 - 6" x 6"	1
SC2-3	G87(CA) Mod	SEE SIGN DETAIL SC2-3	2 - 6" x 6"	1	
SC2-4	G5(CA) Mod	SEE SIGN DETAIL SC2-4	2 - 4" x 6"	1	
STAGE 3	R9-12	SIDEWALK CLOSED AHEAD CROSS HERE		1 - 4" x 4"	2
	W11-2	PEDESTRIAN CROSSING	MOUNT WITH W16-7P - 2 LOCATIONS	1 - 4" x 4"	4
	W11-2	PEDESTRIAN CROSSING	MOUNT WITH W16-9P - 4 LOCATIONS	1 - 4" x 4"	8
	R9-11	SIDEWALK CLOSED USE OTHER SIDE		1 - 4" x 4"	2
STAGE 4	C30(CA)	LANE CLOSED		1 - 4" x 6"	11
	W21-5b(R)	RIGHT SHOULDER CLOSED AHEAD	MOUNT WITH C12(CA)	2 - 6" x 6"	2
	W21-5b(R)	RIGHT SHOULDER CLOSED AHEAD		1 - 4" x 6"	4
	C23(CA)	ROAD WORK AHEAD		1 - 4" x 4"	3
	D13-4	FREEWAY ENTRANCE	MOUNT WITH G27-2(CA) MOUNT WITH M3-3 MOUNT WITH M6-2a(Lt)	1 - 4" x 6"	4
	M3-4	SOUTH	MOUNT WITH G27-2(CA) MOUNT WITH G30A(CA)	1 - 4" x 4"	3
	W4-2	MERGE		1 - 4" x 6"	2
	G84-2(CA)	EXIT WITH ARROW	29	1 - 4" x 6"	1
	C12(CA)	NARROW LANE		1 - 4" x 4"	2
	W20-2	ROAD WORK AHEAD		1 - 4" x 6"	2
	W4-3	LANE ENDS SIGN		1 - 4" x 6"	1
	W9-2	RIGHT LANE ENDS		1 - 4" x 6"	1
C30(CA)	LANE CLOSED		1 - 4" x 6"	10	

(N) - NOT A SEPARATE PAY ITEM.

**STAGE CONSTRUCTION AND
TRAFFIC HANDLING QUANTITIES
SCQ-16**

O:\00300\DRAWING\FINAL_P58E\0420000235mc016.dgn
 STATE OF CALIFORNIA - DEPARTMENT OF TRANSPORTATION
 Errol Caltrans
 CONSULTANT: JAMES VALDIVIA
 SUPERVISOR: ERIN McPHERSON
 DESIGNED BY: JAMIE VALDIVIA
 CHECKED BY: ERIN McPHERSON
 REVISIONS: 9-29-21
 DATE: 9-29-21
 REVISIONS: 9-29-21
 DATE: 9-29-21



Dist	COUNTY	ROUTE	POST MILES TOTAL PROJECT	SHEET No.	TOTAL SHEETS
04	Ala, CC	680	R11.0/R21.9, R0.0/R0.9	792	1710

Erin D. McPherson 9-29-21
 REGISTERED CIVIL ENGINEER DATE

October 8, 2021
 PLANS APPROVAL DATE

THE STATE OF CALIFORNIA OR ITS OFFICERS
 OR AGENTS SHALL NOT BE RESPONSIBLE FOR
 THE ACCURACY OR COMPLETENESS OF SCANNED
 COPIES OF THIS PLAN SHEET.

WMH CORPORATION ALAMEDA CTC
 55 South Market St 1111 Broadway
 Suite 1200 Suite 800
 San Jose, CA 95113 Oakland, CA 94607



CONSTRUCTION AREA SIGNS (STATIONARY MOUNTED)

STAGE No.	DESIGNATION	SIGN MESSAGE	DESCRIPTION	No. OF POSTS AND SIZE	No. OF SIGNS (N)
STAGE 4	SC4-1	E1-5P Mod	SEE SIGN DETAIL SC4-1	2 - 6" x 6"	1
		G83-1(CA) Mod			1
STAGE 5	W21-5b(L)	LEFT SHOULDER CLOSED AHEAD		1 - 4" x 6"	3
	C23(CA)	ROAD WORK AHEAD		1 - 4" x 6"	5
	W21-5b(R)	RIGHT SHOULDER CLOSED AHEAD		1 - 4" x 6"	2

(N) - NOT A SEPARATE BID ITEM.

MOVABLE CONCRETE BARRIER

STAGE No.	STATION		RELOCATE MOVABLE BARRIER	MOVABLE BARRIER CRASH CUSHION	LATERAL SHIFT OF MOVABLE BARRIER	TEMPORARY RAILING (TYPE K)	CHANNELIZER (SURFACE MOUNTED)	ALTERNATIVE TEMPORARY CRASH CUSHION
	FROM	TO	LF	EA	EA	LF	EA	EA
STAGE 3	"I-680" 161+87	"I-680" 684+07	90,000	80	4,400	196	2800	14
TOTAL			90,000	80	4,400	196 *	2800 *	14 *

(*) - QUANTITY INCLUDED IN TEMPORARY TRAFFIC CONTROL DEVICES TABLE.

STAGE CONSTRUCTION AND TRAFFIC HANDLING QUANTITIES
SCQ-17

x
x
x
x
x
x
 STATE OF CALIFORNIA - DEPARTMENT OF TRANSPORTATION
 Et Caltrans
 0:\0030\UDRAFT\ING\FINAL_P58E\0420000235mc017.dgn
 JAMES VALDIVIA
 ERIN McPHERSON
 JAV
 9-29-21
 REVISOR BY
 DATE REVISED
 CALCULATED-DESIGNED BY
 CHECKED BY
 SUPERVISOR
 TIMOTHY J. LEE
 CONSULTANT - FUNCTIONAL SUPERVISOR

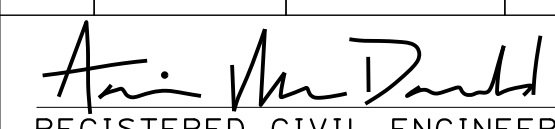
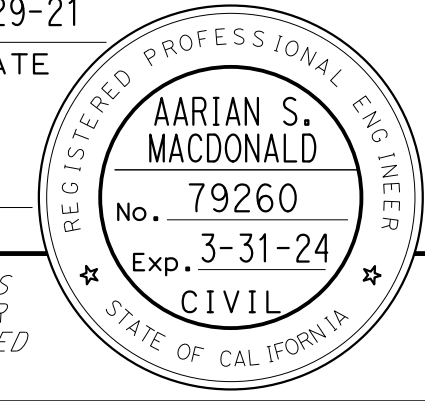

LAST REVISION DATE PLOTTED => 7-MAR-2022
 09-29-21 TIME PLOTTED => 12:03

Dist	COUNTY	ROUTE	POST MILES TOTAL PROJECT	SHEET No.	TOTAL SHEETS
04	Ala, CC	680	R11.0/R21.9, RO.0/RO.9	793	1710
 REGISTERED CIVIL ENGINEER			9-29-21 DATE		
October 8, 2021 PLANS APPROVAL DATE					
WMH CORPORATION 55 South Market St Suite 1200 San Jose, CA 95113			ALAMEDA CTC 1111 Broadway Suite 800 Oakland, CA 94607		

NOTES:

- FOR ACCURATE RIGHT OF WAY DATA, CONTACT RIGHT OF WAY ENGINEERING AT THE DISTRICT OFFICE.
- PLACE BARRIER MARKERS AT CONCRETE BARRIER, THRIE BEAM BARRIER, AND BRIDGE RAILING AT 48' INTERVAL.
- FOR LOCATION OF BARRIER MARKERS ON CONCRETE BARRIER, SEE DETAIL ON SHEET PDD-1.
- INSTALL "EXPRS LANE" PAVEMENT MARKINGS AT 500' SPACING.
- "S" AFTER STRIPING DETAIL NUMBERS REFERS TO CONTRAST STRIPING. SEE S+D PLAN RSP A20E FOR CONTRAST STRIPING DETAIL ON PCC PAVEMENT.
- STRIPING ON NORTHBOUND SIDE OF ROUTE 680 SHALL BE REPLACED IN ORIGINAL LOCATION FOLLOWING REMOVAL OF TEMPORARY STRIPING.

LEGEND:

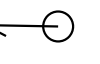
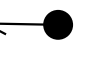
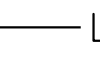
-  PI/BC/EC/PCC/PRC
-  "EXPRS LANE" PAVEMENT MARKING
-  OBJECT MARKER (TYPE X)
-  DELINEATOR (CLASS 1) TYPE F
-  DELINEATOR (CLASS 1) TYPE G
-  12" LIMIT LINE

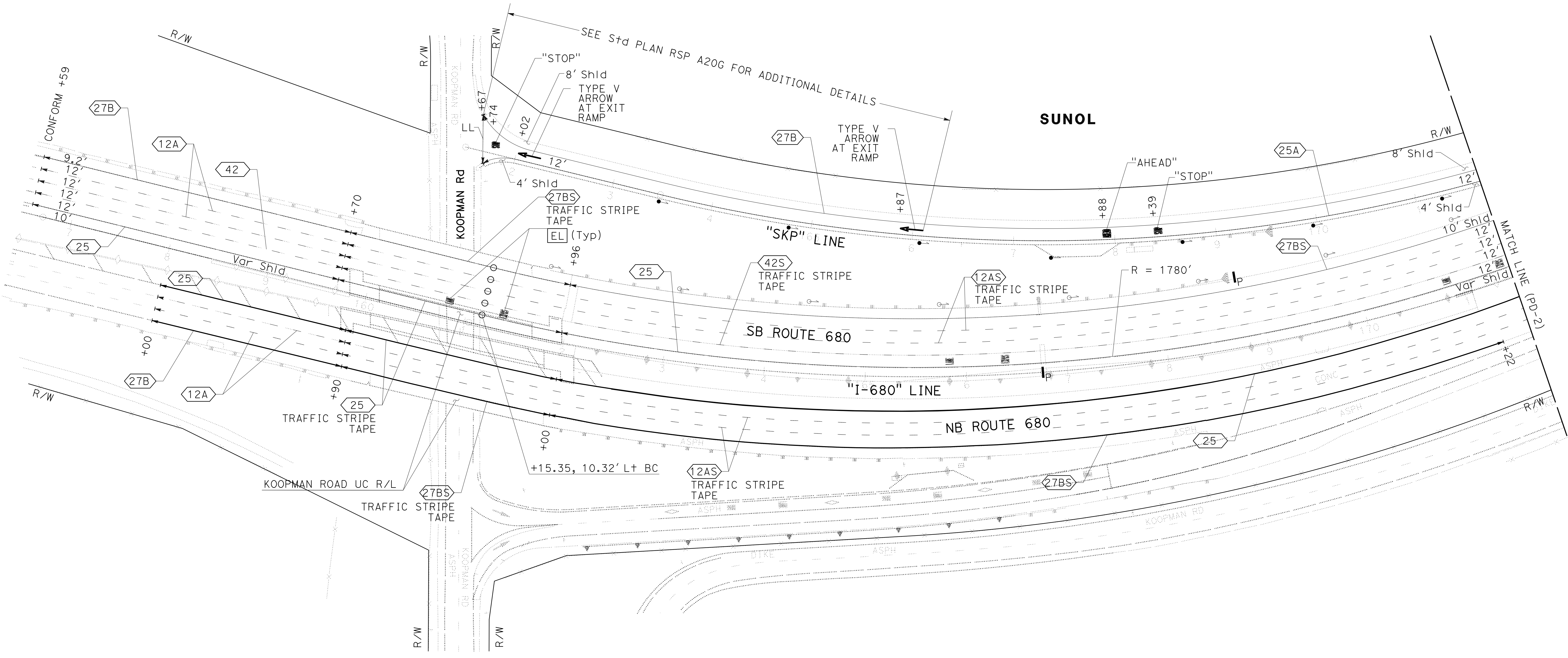
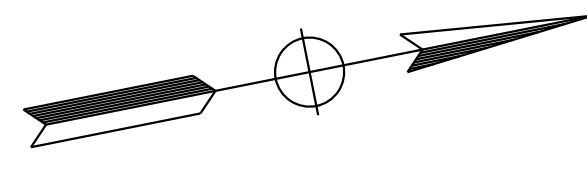

PAVEMENT DELINEATION PLAN

SCALE: 1" = 50'

PD-1

APPROVED FOR PAVEMENT DELINEATION WORK ONLY

O:\0030\UDRAFT\TING\FINAL_P58E\0420000235na001.dgn
 STATE OF CALIFORNIA - DEPARTMENT OF TRANSPORTATION
 Et Caltrans®
 CONSULTANT SUPERVISOR: JONATHAN ROSALES
 CHECKED BY: AARIAN S. MACDONALD
 CALCULATED/DESIGNED BY: AARIAN S. MACDONALD
 REVISIONS: 9-29-21
 DATE REVISED: 9-29-21
 SUPERVISOR: TIMOTHY J. LEE

USERNAME => p302438
 DGN FILE => 0420000235na001.dgn





UNIT 0733

PROJECT NUMBER & PHASE

04200002351

BORDER LAST REVISED 7/2/2010

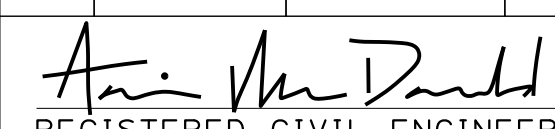
LAST REVISION: 09-29-21
 DATE PLOTTED => 7-MAR-2022
 TIME PLOTTED => 12:03

Dist	COUNTY	ROUTE	POST MILES TOTAL PROJECT	SHEET No.	TOTAL SHEETS
04	Ala, CC	680	R11.0/R21.9, RO.0/RO.9	794	1710
 REGISTERED CIVIL ENGINEER			9-29-21	DATE	
October 8, 2021 PLANS APPROVAL DATE					
WMH CORPORATION 55 South Market St Suite 1200 San Jose, CA 95113			ALAMEDA CTC 1111 Broadway Suite 800 Oakland, CA 94607		

NOTE:
 FOR ACCURATE RIGHT OF WAY DATA, CONTACT
 RIGHT OF WAY ENGINEERING AT THE DISTRICT OFFICE.

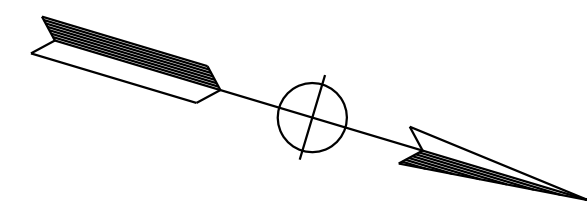

STATE OF CALIFORNIA - DEPARTMENT OF TRANSPORTATION
 CONSULTANT: JONATHAN ROSALES
 CHECKED BY: AARIAN S. MACDONALD
 CALCULATED/DESIGNED BY: JONATHAN ROSALES
 REVISOR: JR
 DATE: 9-29-21
 SUPERVISOR: TIMOTHY J. LEE
 PROJECT: 0420000235na002.dgn

SUNOL

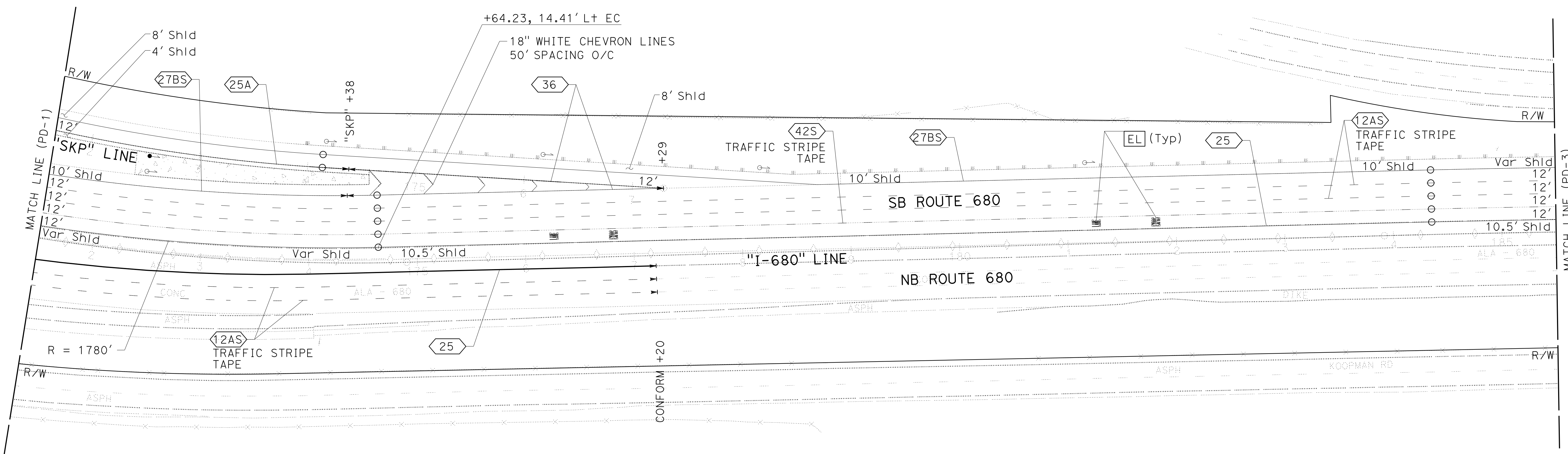

FOR NOTES, ABBREVIATION AND
 LEGEND, SEE SHEET PD-1

APPROVED FOR PAVEMENT DELINEATION WORK ONLY

PAVEMENT DELINEATION PLAN

SCALE: 1" = 50'

PD-2

LAST REVISION: 09-29-21 DATE PLOTTED => 7-MAR-2022 TIME PLOTTED => 12:03

Dist	COUNTY	ROUTE	POST MILES TOTAL PROJECT	SHEET No.	TOTAL SHEETS
04	Ala, CC	680	R11.0/R21.9, R0.0/R0.9	795	1710

REGISTERED CIVIL ENGINEER DATE 9-29-21
 October 8, 2021
 PLANS APPROVAL DATE

THE STATE OF CALIFORNIA OR ITS OFFICERS OR AGENTS SHALL NOT BE RESPONSIBLE FOR THE ACCURACY OR COMPLETENESS OF SCANNED COPIES OF THIS PLAN SHEET.

WMH CORPORATION 55 South Market St Suite 1200 San Jose, CA 95113	ALAMEDA CTC 1111 Broadway Suite 800 Oakland, CA 94607
---	--

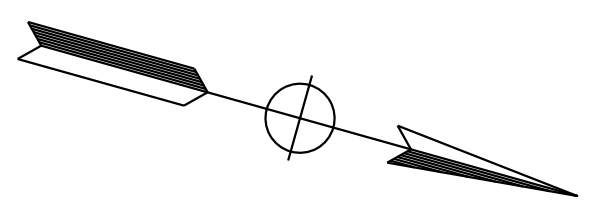
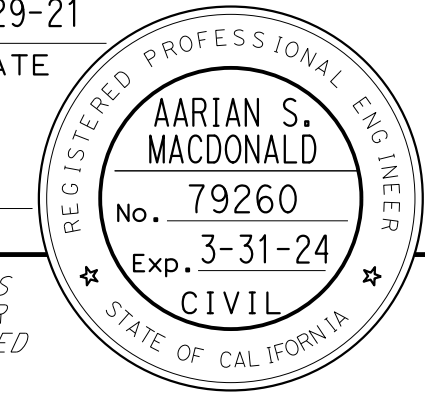

NOTE:
FOR ACCURATE RIGHT OF WAY DATA, CONTACT
RIGHT OF WAY ENGINEERING AT THE DISTRICT OFFICE.

O:\00300\DRAWING\FINAL_P58E\0420000235na003.dgn
 STATE OF CALIFORNIA - DEPARTMENT OF TRANSPORTATION
 Et Caltrans®
 CONSULTANT SUPERVISOR: JONATHAN ROSALES
 CHECKED BY: AARIAN S. MACDONALD
 REVISIONS: 9-29-21
 DATE: 9-29-21
 DESIGNED BY: JONATHAN ROSALES
 CHECKED BY: AARIAN S. MACDONALD
 SUPERVISOR: JONATHAN ROSALES
 CHECKED BY: AARIAN S. MACDONALD
 SUPERVISOR: JONATHAN ROSALES
 CHECKED BY: AARIAN S. MACDONALD

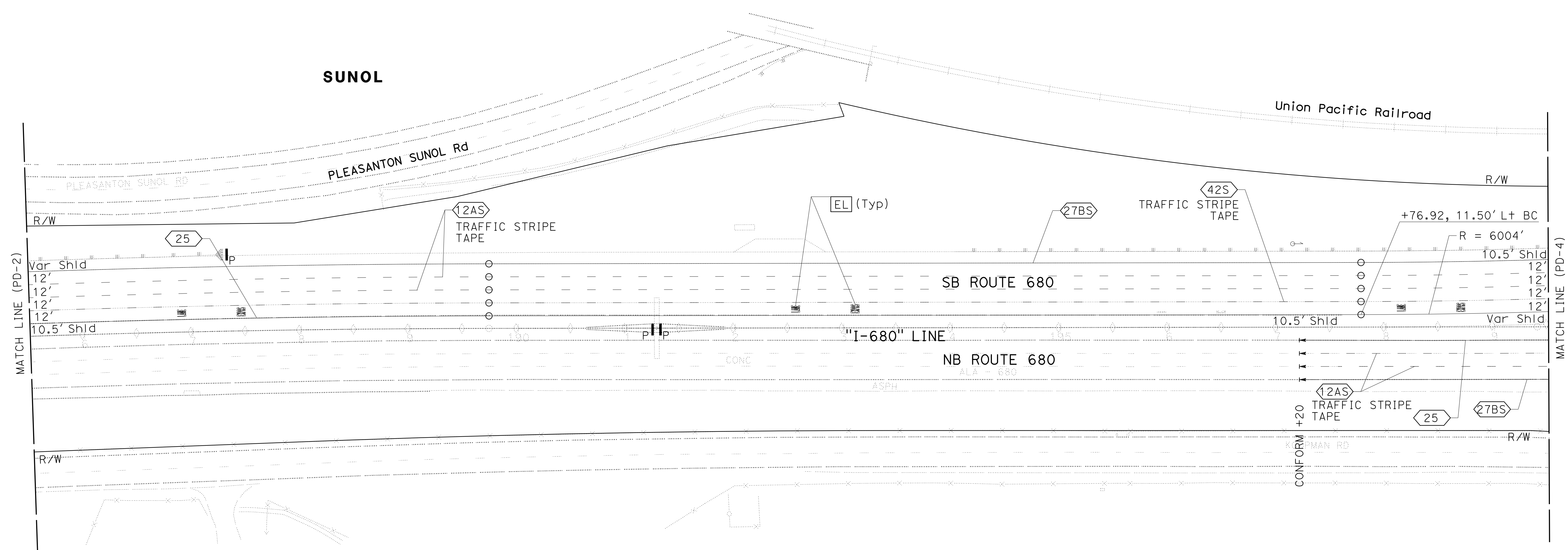

FOR NOTES, ABBREVIATION AND
LEGEND, SEE SHEET PD-1

APPROVED FOR PAVEMENT DELINEATION WORK ONLY

PAVEMENT DELINEATION PLAN

SCALE: 1" = 50'

PD-3

LAST REVISION: 09-29-21 DATE PLOTTED => 7-MAR-2022 TIME PLOTTED => 12:03

O:\00300\DRAWING\FINAL_P5&E\0420000235na004.dgn
 STATE OF CALIFORNIA - DEPARTMENT OF TRANSPORTATION
 Et Caltrans®
 JONATHAN ROSALES
 AARIAN S. MACDONALD
 TIMOTHY J. LEE
 J.R.
 9-29-21

NOTE:
 FOR ACCURATE RIGHT OF WAY DATA, CONTACT
 RIGHT OF WAY ENGINEERING AT THE DISTRICT OFFICE.

Dist	COUNTY	ROUTE	POST MILES TOTAL PROJECT	SHEET No.	TOTAL SHEETS
04	Ala, CC	680	R11.0/R21.9, R0.0/R0.9	796	1710

REGISTERED CIVIL ENGINEER DATE 9-29-21
 October 8, 2021
 PLANS APPROVAL DATE

REGISTERED PROFESSIONAL ENGINEER
AARIAN S. MACDONALD
 No. 79260
 Exp. 3-31-24
 CIVIL
 STATE OF CALIFORNIA

THE STATE OF CALIFORNIA OR ITS OFFICERS OR AGENTS SHALL NOT BE RESPONSIBLE FOR THE ACCURACY OR COMPLETENESS OF SCANNED COPIES OF THIS PLAN SHEET.

WMH CORPORATION 55 South Market St Suite 1200 San Jose, CA 95113	ALAMEDA CTC 1111 Broadway Suite 800 Oakland, CA 94607
---	--

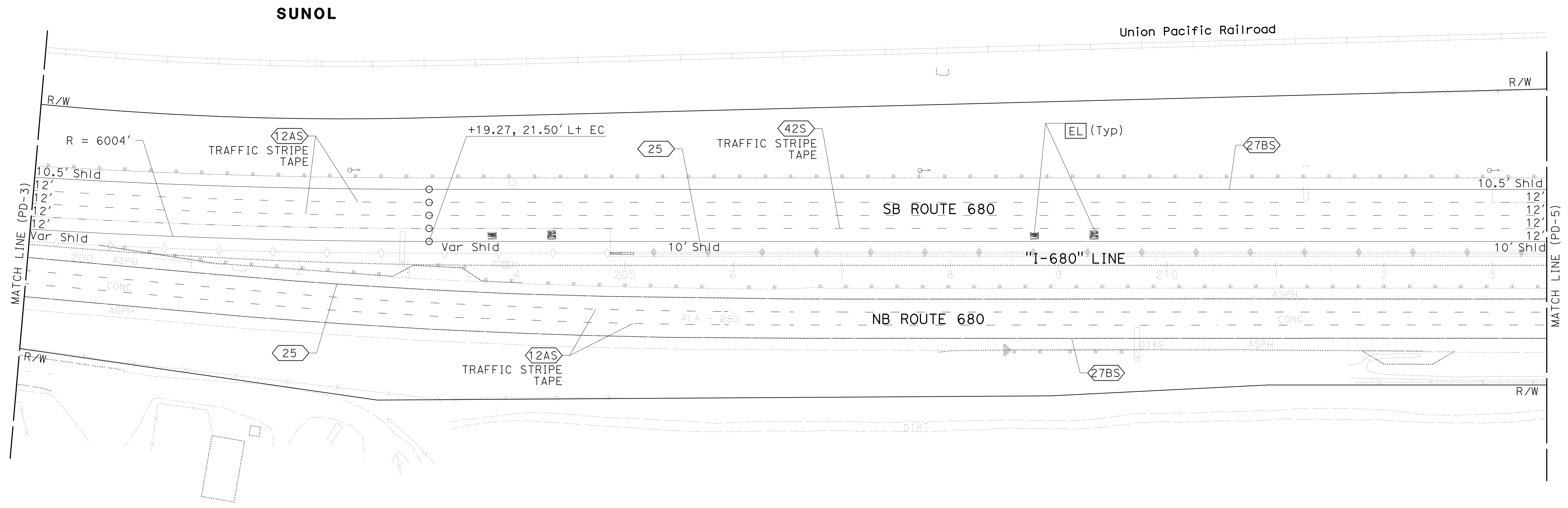
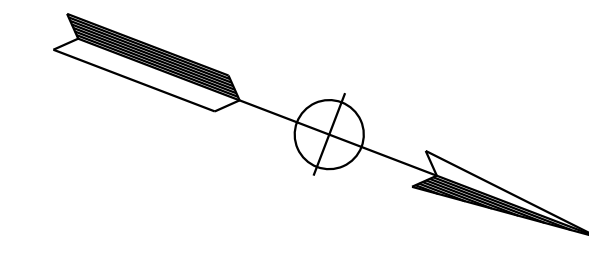

FOR NOTES, ABBREVIATION AND
 LEGEND, SEE SHEET PD-1

APPROVED FOR PAVEMENT DELINEATION WORK ONLY

PAVEMENT DELINEATION PLAN

SCALE: 1" = 50'

PD-4

LAST REVISION: DATE PLOTTED => 7-MAR-2022
 09-29-21 TIME PLOTTED => 12:03

NOTE:
FOR ACCURATE RIGHT OF WAY DATA, CONTACT
RIGHT OF WAY ENGINEERING AT THE DISTRICT OFFICE.

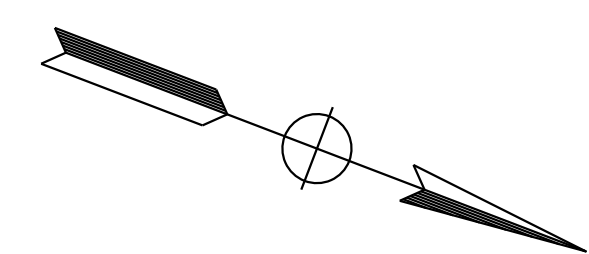

Dist	COUNTY	ROUTE	POST MILES TOTAL PROJECT	SHEET No.	TOTAL SHEETS
04	Ala, CC	680	R11.0/R21.9, R0.0/R0.9	797	1710

REGISTERED CIVIL ENGINEER DATE 9-29-21
 October 8, 2021
 PLANS APPROVAL DATE

THE STATE OF CALIFORNIA OR ITS OFFICERS
 OR AGENTS SHALL NOT BE RESPONSIBLE FOR
 THE ACCURACY OR COMPLETENESS OF SCANNED
 COPIES OF THIS PLAN SHEET.

WMH CORPORATION 55 South Market St Suite 1200 San Jose, CA 95113	ALAMEDA CTC 1111 Broadway Suite 800 Oakland, CA 94607
---	--

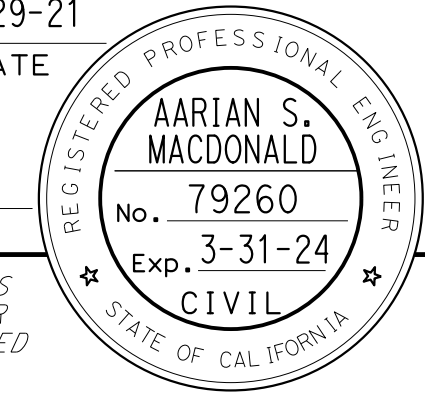

SUNOL

Union Pacific Railroad

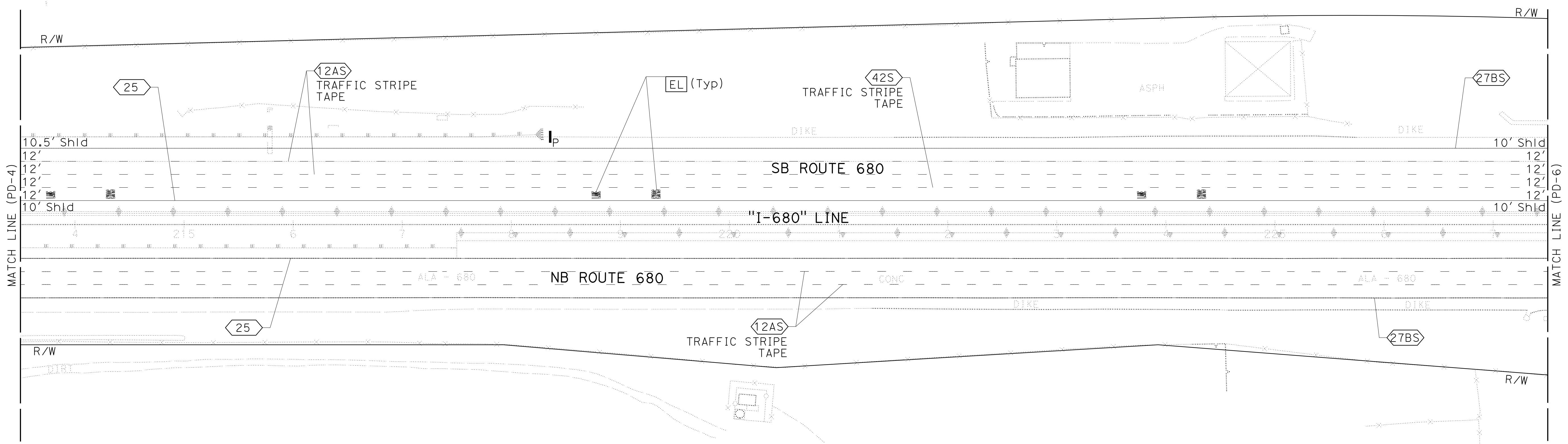

PAVEMENT DELINEATION PLAN

SCALE: 1" = 50'

PD-5

FOR NOTES, ABBREVIATION AND
LEGEND, SEE SHEET PD-1

APPROVED FOR PAVEMENT DELINEATION WORK ONLY

0:\0030\UDRAFT\ING\FINAL_P58E\0420000235na005.dgn
 STATE OF CALIFORNIA - DEPARTMENT OF TRANSPORTATION
 Et Caltrans®
 CONSULTANT SUPERVISOR: JONATHAN ROSALES
 CHECKED BY: AARIAN S. MACDONALD
 REVISIONS: 9-29-21
 DATE: 9-29-21
 BY: JR

USERNAME => p302438
DGN FILE => 0420000235na005.dgn

RELATIVE BORDER SCALE
15 IN INCHES

UNIT 0733

PROJECT NUMBER & PHASE

04200002351

LAST REVISION: 09-29-21
 DATE PLOTTED: 09-29-21
 TIME PLOTTED: 12:03

NOTE:
FOR ACCURATE RIGHT OF WAY DATA, CONTACT
RIGHT OF WAY ENGINEERING AT THE DISTRICT OFFICE.

Dist	COUNTY	ROUTE	POST MILES TOTAL PROJECT	SHEET No.	TOTAL SHEETS
04	Ala, CC	680	R11.0/R21.9, R0.0/R0.9	798	1710

Arian S. Macdonald 9-29-21
 REGISTERED CIVIL ENGINEER DATE
 October 8, 2021
 PLANS APPROVAL DATE

REGISTERED PROFESSIONAL ENGINEER
AARIAN S. MACDONALD
 No. 79260
 Exp. 3-31-24
 CIVIL
 STATE OF CALIFORNIA

THE STATE OF CALIFORNIA OR ITS OFFICERS OR AGENTS SHALL NOT BE RESPONSIBLE FOR THE ACCURACY OR COMPLETENESS OF SCANNED COPIES OF THIS PLAN SHEET.
 WMH CORPORATION ALAMEDA CTC
 55 South Market St Suite 1200 1111 Broadway
 San Jose, CA 95113 Suite 800 Oakland, CA 94607

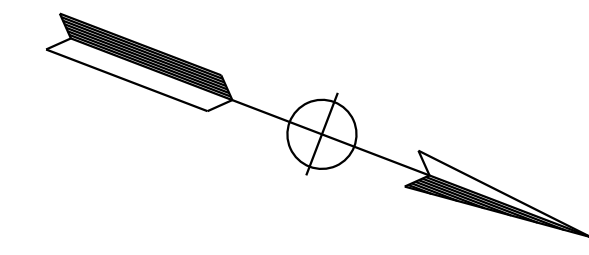

SUNOL

Union Pacific Railroad

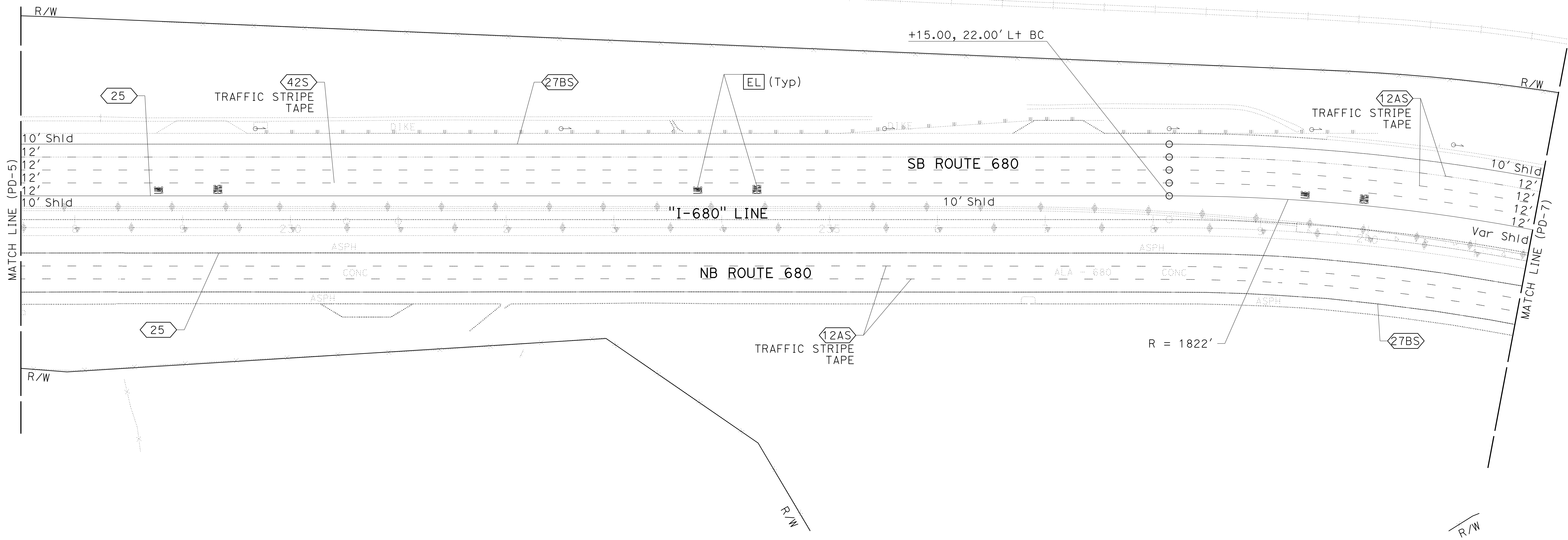

O:\0030\DRAWING\FINAL_P58E\0420000235na006.dgn
 STATE OF CALIFORNIA - DEPARTMENT OF TRANSPORTATION
 CONSULTANT FUNCTIONAL SUPERVISOR
 JONATHAN ROSALES
 AARIAN S. MACDONALD
 CALCULATED/DESIGNED BY
 CHECKED BY
 TIMOTHY J. LEE
 REVISOR
 JR
 9-29-21
 DATE REVISED
 DATE



FOR NOTES, ABBREVIATION AND
LEGEND, SEE SHEET PD-1

APPROVED FOR PAVEMENT DELINEATION WORK ONLY

PAVEMENT DELINEATION PLAN

SCALE: 1" = 50'

PD-6

LAST REVISION DATE PLOTTED => 7-MAR-2022
 09-29-21 TIME PLOTTED => 12:03

Dist	COUNTY	ROUTE	POST MILES TOTAL PROJECT	SHEET No.	TOTAL SHEETS
04	Ala, CC	680	R11.0/R21.9, R0.0/R0.9	799	1710

Arian S. Macdonald
 REGISTERED CIVIL ENGINEER DATE 9-29-21
 October 8, 2021
 PLANS APPROVAL DATE
 THE STATE OF CALIFORNIA OR ITS OFFICERS OR AGENTS SHALL NOT BE RESPONSIBLE FOR THE ACCURACY OR COMPLETENESS OF SCANNED COPIES OF THIS PLAN SHEET.



WMH CORPORATION 55 South Market St Suite 1200 San Jose, CA 95113
 ALAMEDA CTC 1111 Broadway Suite 800 Oakland, CA 94607

NOTE:
 FOR ACCURATE RIGHT OF WAY DATA, CONTACT RIGHT OF WAY ENGINEERING AT THE DISTRICT OFFICE.

STATE OF CALIFORNIA - DEPARTMENT OF TRANSPORTATION
 CONSULTANT FUNCTIONAL SUPERVISOR
 JONATHAN ROSALES
 AARIAN S. MACDONALD
 CHECKED BY
 TIMOTHY J. LEE
 REVISOR BY
 DATE REVISOR
 9-29-21

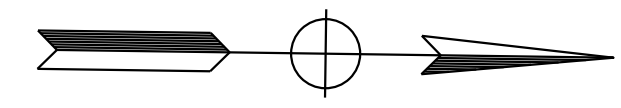

SUNOL

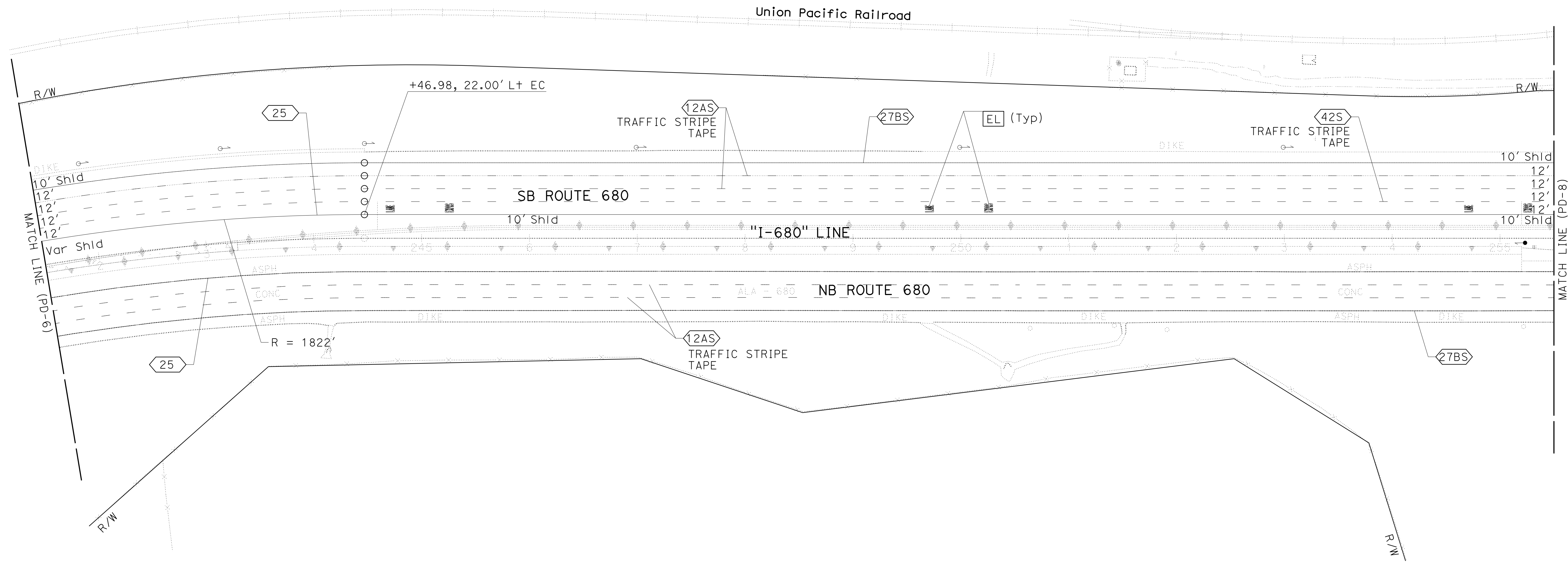

FOR NOTES, ABBREVIATION AND LEGEND, SEE SHEET PD-1

APPROVED FOR PAVEMENT DELINEATION WORK ONLY

PAVEMENT DELINEATION PLAN

SCALE: 1" = 50'

PD-7

LAST REVISION DATE PLOTTED => 7-MAR-2022
 09-29-21 TIME PLOTTED => 12:03

Dist	COUNTY	ROUTE	POST MILES TOTAL PROJECT	SHEET No.	TOTAL SHEETS
04	Ala, CC	680	R11.0/R21.9, R0.0/R0.9	800	1710

REGISTERED CIVIL ENGINEER DATE 9-29-21
 October 8, 2021
 PLANS APPROVAL DATE

THE STATE OF CALIFORNIA OR ITS OFFICERS OR AGENTS SHALL NOT BE RESPONSIBLE FOR THE ACCURACY OR COMPLETENESS OF SCANNED COPIES OF THIS PLAN SHEET.

WMH CORPORATION 55 South Market St Suite 1200 San Jose, CA 95113	ALAMEDA CTC 1111 Broadway Suite 800 Oakland, CA 94607
---	--

NOTE:
FOR ACCURATE RIGHT OF WAY DATA, CONTACT
RIGHT OF WAY ENGINEERING AT THE DISTRICT OFFICE.

DESIGNED BY	REVISOR	DATE
JONATHAN ROSALES	JR	9-29-21
CHECKED BY	DESIGNED BY	DATE
AARIAN S. MACDONALD	JONATHAN ROSALES	9-29-21
FUNCTIONAL SUPERVISOR	CHECKED BY	DATE
TIMOTHY J. LEE	AARIAN S. MACDONALD	9-29-21

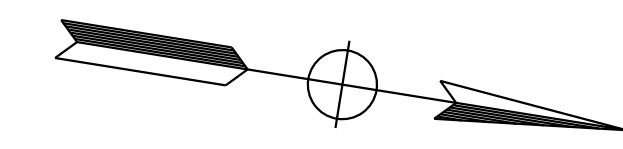
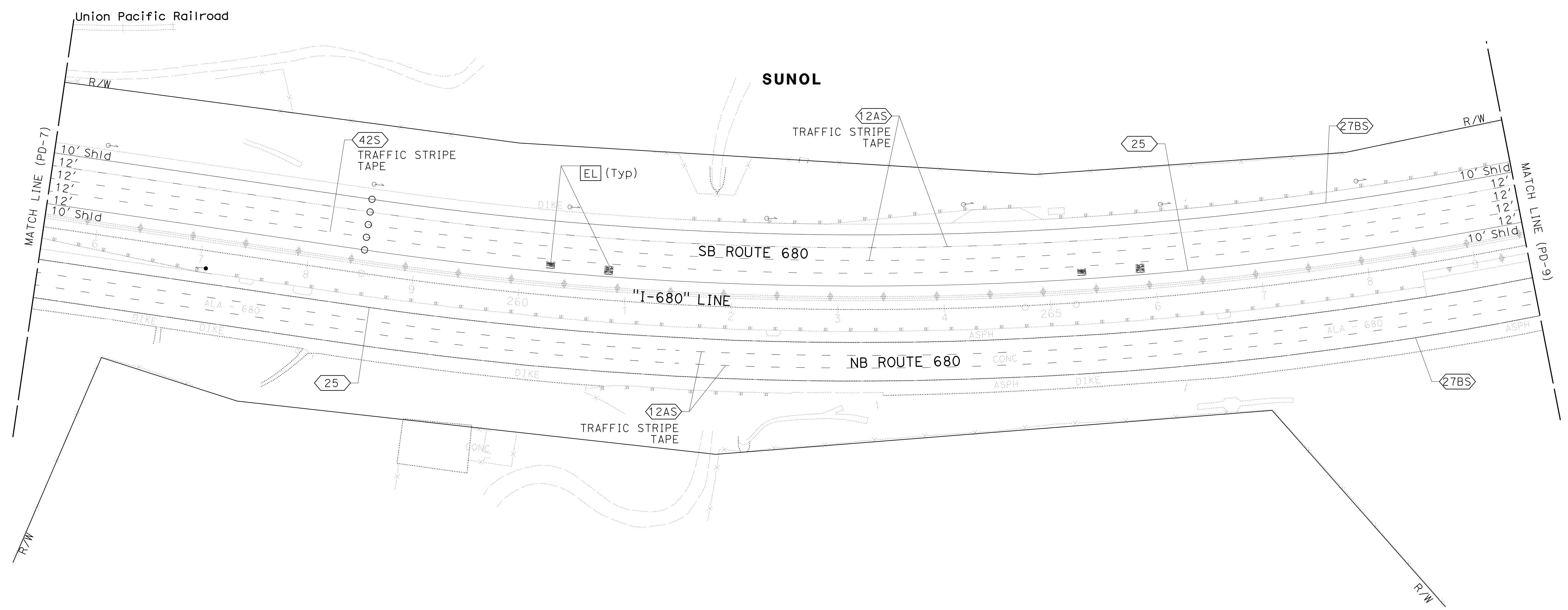

FOR NOTES, ABBREVIATION AND
LEGEND, SEE SHEET PD-1

APPROVED FOR PAVEMENT DELINEATION WORK ONLY

PAVEMENT DELINEATION PLAN

SCALE: 1" = 50'

PD-8