

Dist	COUNTY	ROUTE	POST MILES TOTAL PROJECT	SHEET No.	TOTAL SHEETS
04	Ala, CC	680	R11.0/R21.9, R0.0/R0.9	601	1710
			9-29-21		
REGISTERED CIVIL ENGINEER			DATE		
			October 8, 2021		
			PLANS APPROVAL DATE		
<small>THE STATE OF CALIFORNIA OR ITS OFFICERS OR AGENTS SHALL NOT BE RESPONSIBLE FOR THE ACCURACY OR COMPLETENESS OF SCANNED COPIES OF THIS PLAN SHEET.</small>					
WMH CORPORATION 55 South Market St Suite 1200 San Jose, CA 95113			ALAMEDA CTC 1111 Broadway Suite 800 Oakland, CA 94607		

NOTE:  
FOR ACCURATE RIGHT OF WAY DATA, CONTACT  
RIGHT OF WAY ENGINEERING AT THE DISTRICT OFFICE.

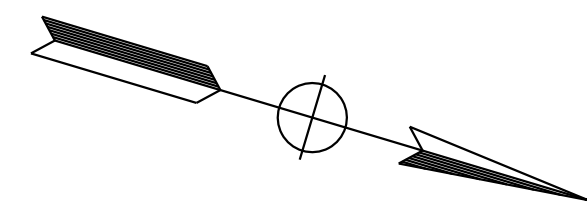

DESIGNED BY	JAMEY VALDIVIA
CHECKED BY	ERIN MCPHERSON
REVISIONS	
DATE	9-29-21
BY	JV
REVISIONS	
DATE	
BY	
DESIGNED BY	TIMOTHY J. LEE
CHECKED BY	
REVISIONS	
DATE	
BY	
DESIGNED BY	
CHECKED BY	
REVISIONS	
DATE	
BY	

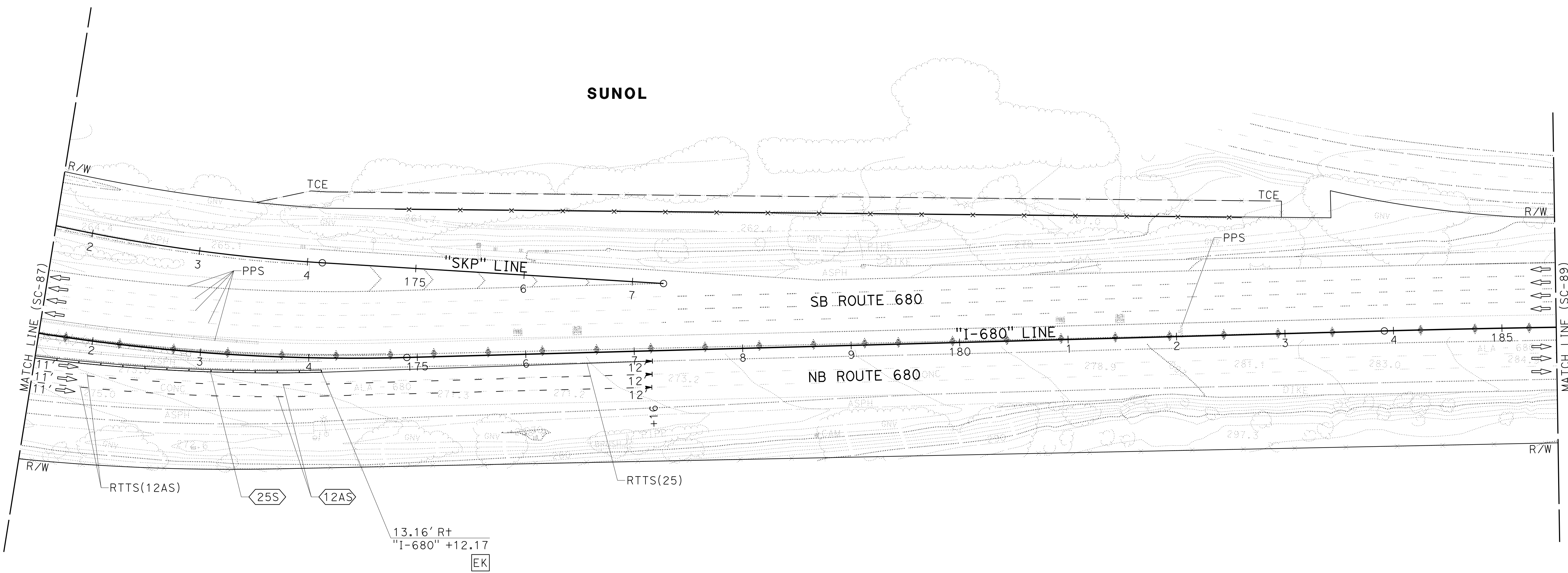

FOR NOTES, ABBREVIATIONS AND  
LEGEND, SEE SHEET SC-1 AND SC-87

APPROVED FOR STAGE CONSTRUCTION AND TRAFFIC HANDLING WORK ONLY

# STAGE CONSTRUCTION AND TRAFFIC HANDLING PLAN

STAGE 1 PHASE 2B

SCALE: 1" = 50'

SC-88

LAST REVISION: DATE PLOTTED => 8-MAR-2022 09-29-21 TIME PLOTTED => 10:03

Dist	COUNTY	ROUTE	POST MILES TOTAL PROJECT	SHEET No.	TOTAL SHEETS
04	Ala, CC	680	R11.0/R21.9, R0.0/R0.9	602	1710

<i>Erin D. McPherson</i>	9-29-21
REGISTERED CIVIL ENGINEER	DATE
October 8, 2021	
PLANS APPROVAL DATE	

  

ERIN D. McPHERSON No. C91111 Exp 3-31-24 CIVIL STATE OF CALIFORNIA	THE STATE OF CALIFORNIA OR ITS OFFICERS OR AGENTS SHALL NOT BE RESPONSIBLE FOR THE ACCURACY OR COMPLETENESS OF SCANNED COPIES OF THIS PLAN SHEET.
WMH CORPORATION 55 South Market St Suite 1200 San Jose, CA 95113	ALAMEDA CTC 1111 Broadway Suite 800 Oakland, CA 94607

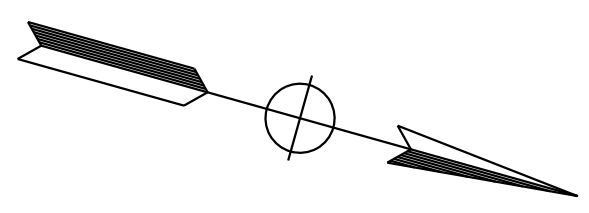

NOTE:  
FOR ACCURATE RIGHT OF WAY DATA, CONTACT  
RIGHT OF WAY ENGINEERING AT THE DISTRICT OFFICE.

DESIGNED BY	JV
DATE	9-29-21
REVISOR	
DATE	
DESIGNED BY	JAMEY VALDIVIA
CHECKED BY	ERIN MCPHERSON
DESIGNED BY	
CHECKED BY	
CONSULTANT SUPERVISOR	TIMOTHY J. LEE
FUNCTIONAL SUPERVISOR	
DESIGNED BY	
CHECKED BY	

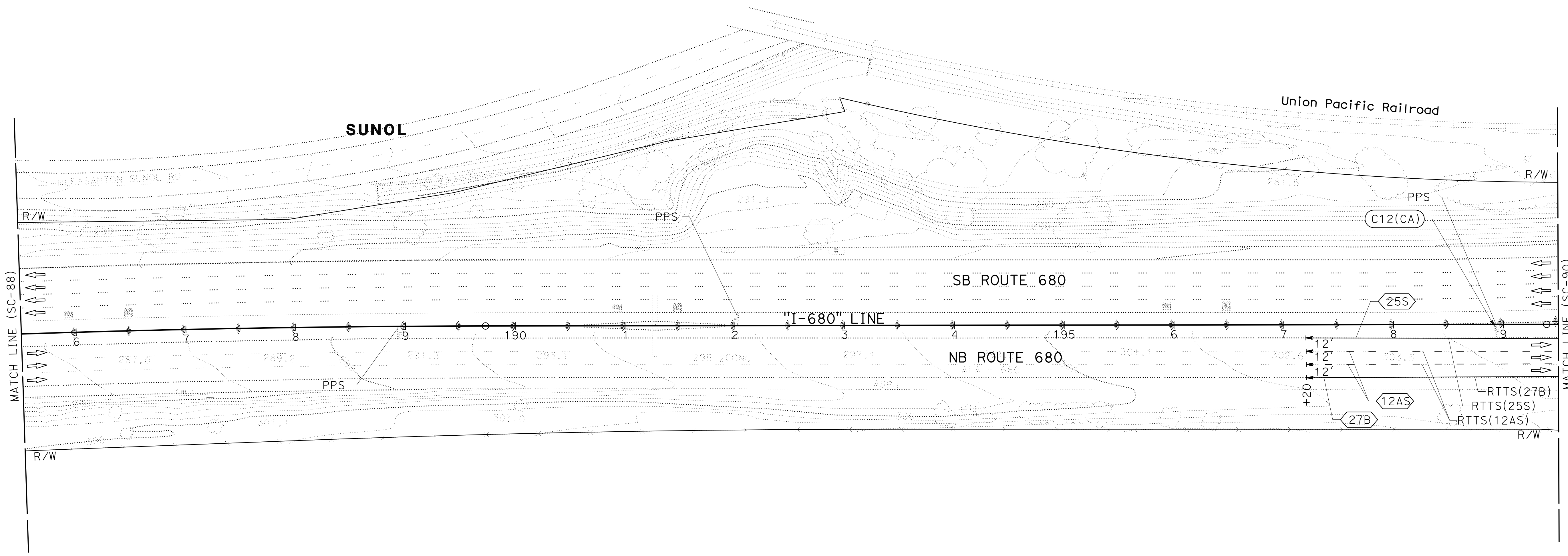

FOR NOTES, ABBREVIATIONS AND  
LEGEND, SEE SHEET SC-1 AND SC-87

APPROVED FOR STAGE CONSTRUCTION AND TRAFFIC HANDLING WORK ONLY

**STAGE CONSTRUCTION  
AND TRAFFIC HANDLING PLAN**

**STAGE 1 PHASE 2B**

SCALE: 1" = 50'

**SC-89**

LAST REVISION: 09-29-21 DATE PLOTTED => 8-MAR-2022 TIME PLOTTED => 10:04

Dist	COUNTY	ROUTE	POST MILES TOTAL PROJECT	SHEET No.	TOTAL SHEETS
04	Ala, CC	680	R11.0/R21.9, R0.0/R0.9	603	1710

  

<i>Erin D. McPherson</i>		9-29-21
REGISTERED CIVIL ENGINEER	DATE	
October 8, 2021		
PLANS APPROVAL DATE		

REGISTERED PROFESSIONAL ENGINEER <b>ERIN D. McPHERSON</b> No. C91111 Exp. 3-31-24 CIVIL STATE OF CALIFORNIA	
WMH CORPORATION 55 South Market St Suite 1200 San Jose, CA 95113	ALAMEDA CTC 1111 Broadway Suite 800 Oakland, CA 94607

NOTE:  
FOR ACCURATE RIGHT OF WAY DATA, CONTACT  
RIGHT OF WAY ENGINEERING AT THE DISTRICT OFFICE.

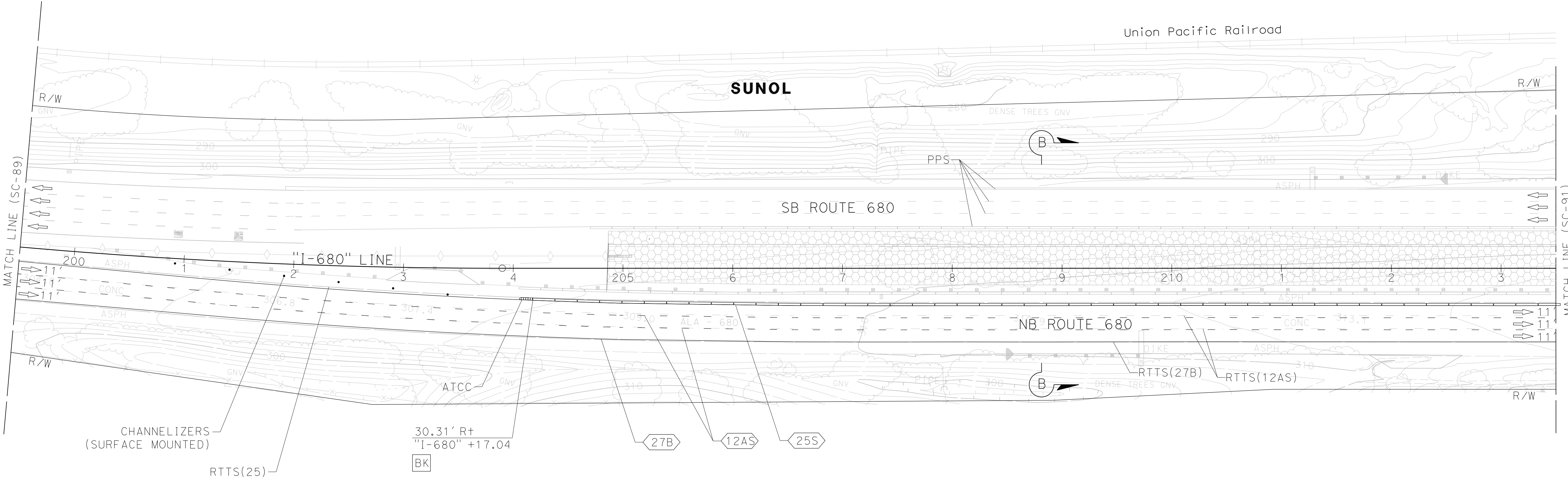
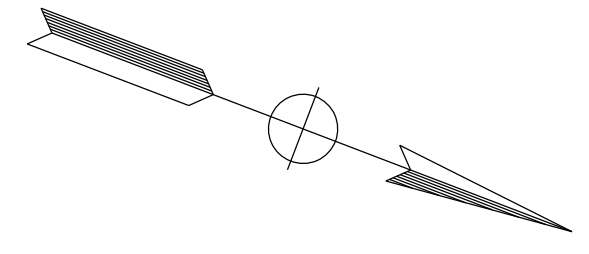

**STAGE CONSTRUCTION  
AND TRAFFIC HANDLING PLAN**  
**STAGE 1 PHASE 2B**  
SCALE: 1" = 50'  
**SC-90**

APPROVED FOR STAGE CONSTRUCTION AND TRAFFIC HANDLING WORK ONLY

FOR NOTES, ABBREVIATIONS AND  
LEGEND, SEE SHEET SC-1 AND SC-87

X:\680\_SB\_EXPRESS\000\_CAD\Submit\11\11\CADD\_submit\11\11\0420000235ma090.dgn  
 STATE OF CALIFORNIA - DEPARTMENT OF TRANSPORTATION  
 CONSULTANT FUNCTIONAL SUPERVISOR: TIMOTHY J. LEE  
 CALCULATED/DESIGNED BY: JAMEY VALDIVIA  
 CHECKED BY: ERIN McPHERSON  
 REVISED BY: J.V.  
 DATE REVISED: 9-29-21

LAST REVISION: 09-29-21    DATE PLOTTED => 3/18/2022    TIME PLOTTED => 4:33:50 PM

Dist	COUNTY	ROUTE	POST MILES TOTAL PROJECT	SHEET No.	TOTAL SHEETS
04	Ala, CC	680	R11.0/R21.9, R0.0/R0.9	604	1710
			9-29-21		
REGISTERED CIVIL ENGINEER			DATE		
			October 8, 2021		
			PLANS APPROVAL DATE		
<small>THE STATE OF CALIFORNIA OR ITS OFFICERS OR AGENTS SHALL NOT BE RESPONSIBLE FOR THE ACCURACY OR COMPLETENESS OF SCANNED COPIES OF THIS PLAN SHEET.</small>					
WMH CORPORATION 55 South Market St Suite 1200 San Jose, CA 95113			ALAMEDA CTC 1111 Broadway Suite 800 Oakland, CA 94607		

NOTE:  
FOR ACCURATE RIGHT OF WAY DATA, CONTACT  
RIGHT OF WAY ENGINEERING AT THE DISTRICT OFFICE.

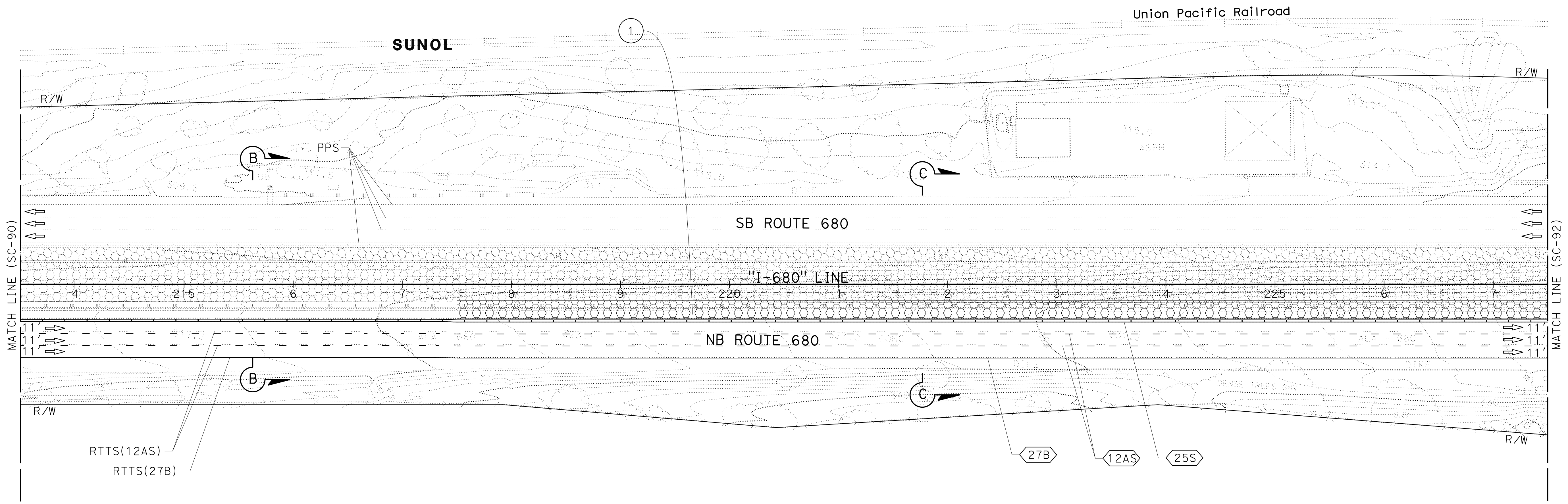
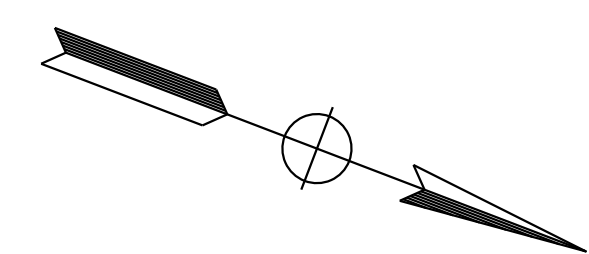

**STAGE CONSTRUCTION  
AND TRAFFIC HANDLING PLAN**  
**STAGE 1 PHASE 2B**  
SCALE: 1" = 50'  
**SC-91**

FOR NOTES, ABBREVIATIONS AND  
LEGEND, SEE SHEET SC-1 AND SC-87

APPROVED FOR STAGE CONSTRUCTION AND TRAFFIC HANDLING WORK ONLY

O:\00300\DRAWING\FINAL\_P&E\0420000235mo091.dgn  
 STATE OF CALIFORNIA - DEPARTMENT OF TRANSPORTATION  
 Et Caltrans®  
 CONSULTANT SUPERVISOR: TIMOTHY J. LEE  
 CALCULATED/DESIGNED BY: JAMEY VALDIVIA  
 CHECKED BY: ERIN MCPHERSON  
 REVISED BY: J.V.  
 DATE REVISED: 9-29-21

Dist	COUNTY	ROUTE	POST MILES TOTAL PROJECT	SHEET No.	TOTAL SHEETS
04	Ala, CC	680	R11.0/R21.9, R0.0/R0.9	605	1710

<i>Erin D. McPherson</i>	9-29-21
REGISTERED CIVIL ENGINEER	DATE
October 8, 2021	
PLANS APPROVAL DATE	

REGISTERED PROFESSIONAL ENGINEER <b>ERIN D. McPHERSON</b> No. C91111 Exp. 3-31-24 CIVIL STATE OF CALIFORNIA
----------------------------------------------------------------------------------------------------------------------------

  

WMH CORPORATION 55 South Market St Suite 1200 San Jose, CA 95113	ALAMEDA CTC 1111 Broadway Suite 800 Oakland, CA 94607
---------------------------------------------------------------------------	----------------------------------------------------------------

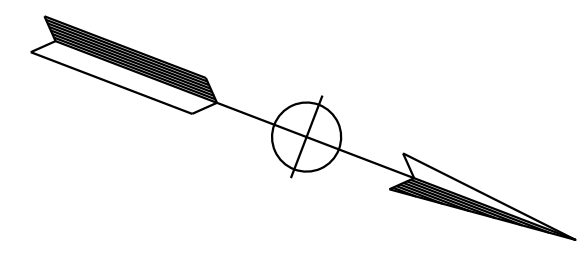

NOTE:  
FOR ACCURATE RIGHT OF WAY DATA, CONTACT  
RIGHT OF WAY ENGINEERING AT THE DISTRICT OFFICE.

STATE OF CALIFORNIA - DEPARTMENT OF TRANSPORTATION	CONSULTANT FUNCTIONAL SUPERVISOR	DESIGNED BY	REVISOR	DATE
Erin D. McPherson	TIMOTHY J. LEE	ERIN McPHERSON	JV	9-29-21
Erin D. McPherson		JAMEY VALDIVIA		
		ERIN McPHERSON		

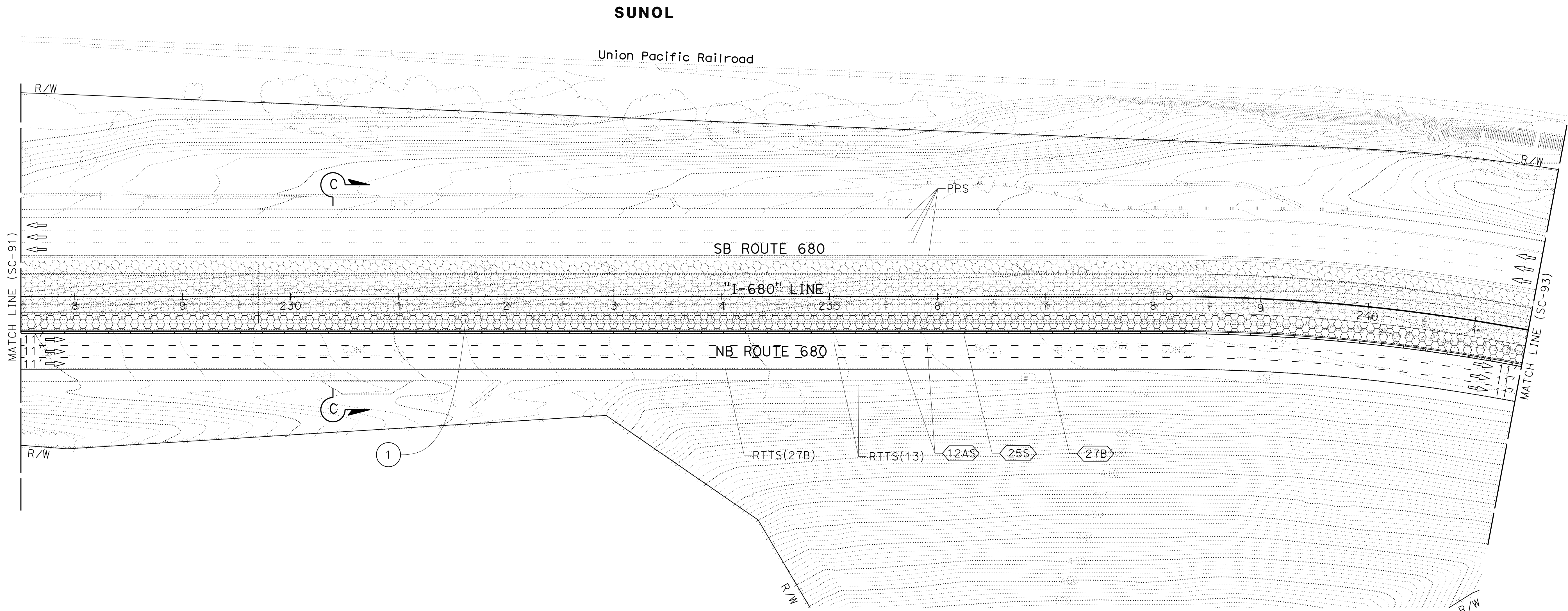

**STAGE CONSTRUCTION  
AND TRAFFIC HANDLING PLAN**  
**STAGE 1 PHASE 2B**  
SCALE: 1" = 50'  
**SC-92**

FOR NOTES, ABBREVIATIONS AND  
LEGEND, SEE SHEET SC-1 AND SC-87

APPROVED FOR STAGE CONSTRUCTION AND TRAFFIC HANDLING WORK ONLY

Dist	COUNTY	ROUTE	POST MILES TOTAL PROJECT	SHEET No.	TOTAL SHEETS
04	Ala, CC	680	R11.0/R21.9, R0.0/R0.9	606	1710

<i>Erin D. McPherson</i>		9-29-21
REGISTERED CIVIL ENGINEER	DATE	
October 8, 2021		
PLANS APPROVAL DATE		

THE STATE OF CALIFORNIA OR ITS OFFICERS OR AGENTS SHALL NOT BE RESPONSIBLE FOR THE ACCURACY OR COMPLETENESS OF SCANNED COPIES OF THIS PLAN SHEET.	
---------------------------------------------------------------------------------------------------------------------------------------------------	--

  

WMH CORPORATION 55 South Market St Suite 1200 San Jose, CA 95113	ALAMEDA CTC 1111 Broadway Suite 800 Oakland, CA 94607
---------------------------------------------------------------------------	----------------------------------------------------------------

**NOTES:**

- FOR ACCURATE RIGHT OF WAY DATA, CONTACT RIGHT OF WAY ENGINEERING AT THE DISTRICT OFFICE.
- FOR ADDITIONAL SIGN DETAILS, SEE STAGE CONSTRUCTION DETAILS SHEETS.

REVISOR	DATE	REVISION
JV	9-29-21	
REVISOR	DATE	REVISION
JAMEY VALDIVIA		
ERIN MCPHERSON		
CALCULATED-DESIGNED BY	CHECKED BY	
TIMOTHY J. LEE		
CONSULTANT FUNCTIONAL SUPERVISOR		
DEPARTMENT OF TRANSPORTATION		
STATE OF CALIFORNIA		

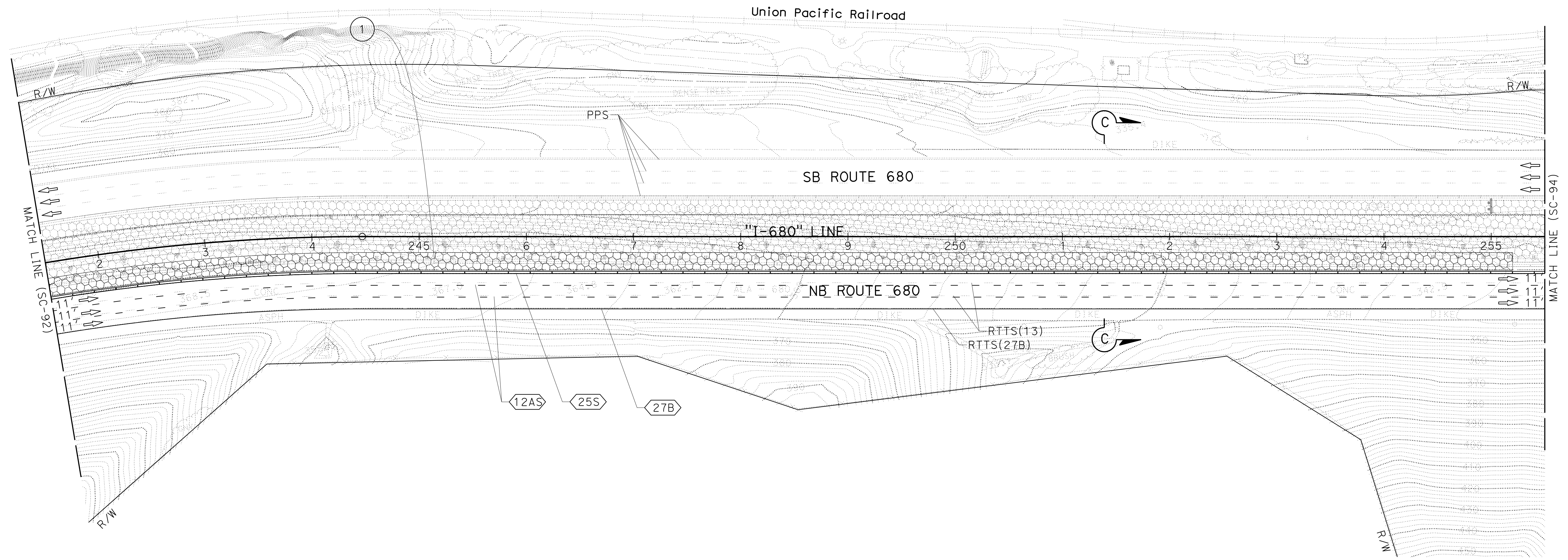
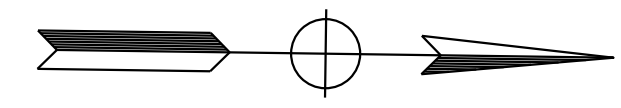

FOR NOTES, ABBREVIATIONS AND LEGEND, SEE SHEET SC-1 AND SC-87

APPROVED FOR STAGE CONSTRUCTION AND TRAFFIC HANDLING WORK ONLY

**STAGE CONSTRUCTION AND TRAFFIC HANDLING PLAN**

**STAGE 1 PHASE 2B**

SCALE: 1" = 50'

**SC-93**

LAST REVISION: DATE PLOTTED => 8-MAR-2022 09-29-21 TIME PLOTTED => 10:04

Dist	COUNTY	ROUTE	POST MILES TOTAL PROJECT	SHEET No.	TOTAL SHEETS
04	Ala, CC	680	R11.0/R21.9, R0.0/R0.9	607	1710

<i>Erin D. McPherson</i>	9-29-21
REGISTERED CIVIL ENGINEER	DATE
October 8, 2021	
PLANS APPROVAL DATE	

ERIN D. McPHERSON No. C91111 Exp 3-31-24 CIVIL STATE OF CALIFORNIA
-----------------------------------------------------------------------------------

WMH CORPORATION 55 South Market St Suite 1200 San Jose, CA 95113	ALAMEDA CTC 1111 Broadway Suite 800 Oakland, CA 94607
---------------------------------------------------------------------------	----------------------------------------------------------------

NOTE:  
FOR ACCURATE RIGHT OF WAY DATA, CONTACT  
RIGHT OF WAY ENGINEERING AT THE DISTRICT OFFICE.

REVISOR	DATE	REVISION
JV	9-29-21	
CALCULATED-DESIGNED BY	CHECKED BY	
JAMEY VALDIVIA	ERIN MCPHERSON	
CONSULTANT FUNCTIONAL SUPERVISOR		
TIMOTHY J. LEE		
DEPARTMENT OF TRANSPORTATION		

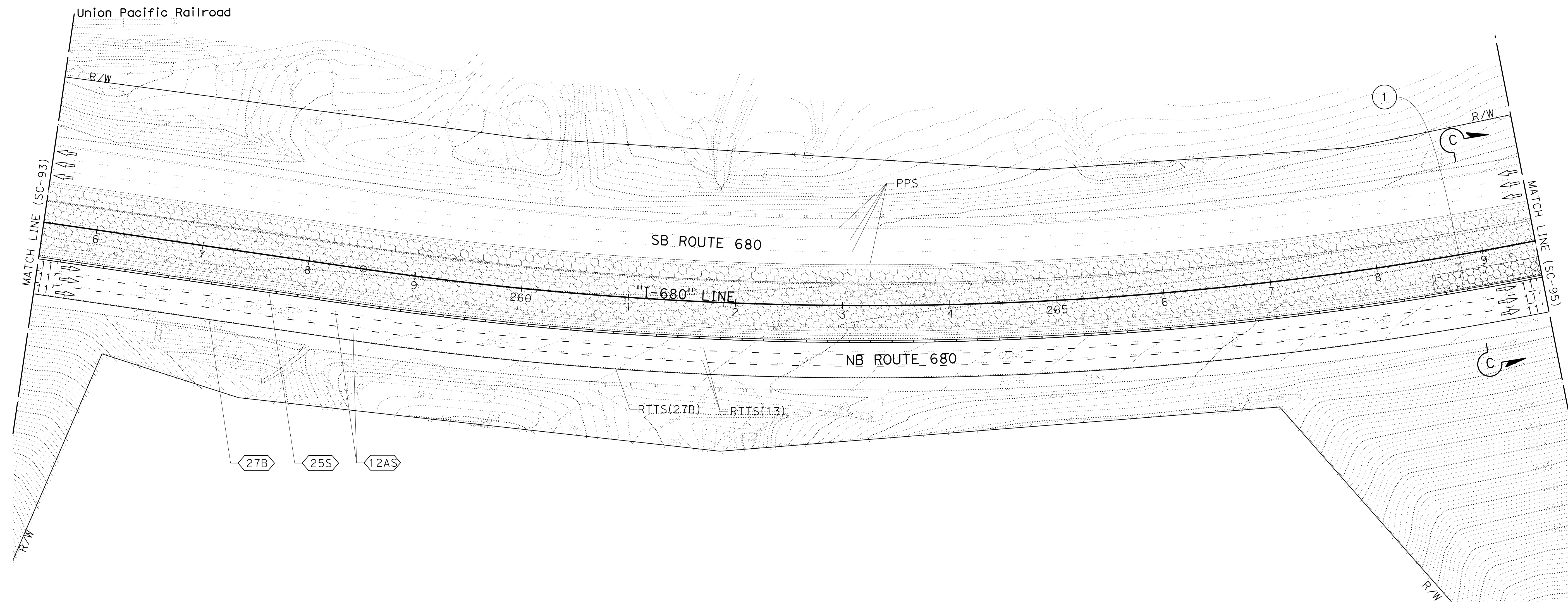

**STAGE CONSTRUCTION  
AND TRAFFIC HANDLING PLAN**  
**STAGE 1 PHASE 2B**  
SCALE: 1" = 50'  
**SC-94**

FOR NOTES, ABBREVIATIONS AND  
LEGEND, SEE SHEET SC-1 AND SC-87

APPROVED FOR STAGE CONSTRUCTION AND TRAFFIC HANDLING WORK ONLY

O:\00300\DRAWING\FINAL\_P5&E\0420000235mo095.dgn  
 STATE OF CALIFORNIA - DEPARTMENT OF TRANSPORTATION  
**Caltrans**  
 CONSULTANT - FUNCTIONAL SUPERVISOR  
 JAMEY VALDIVIA  
 ERIN McPHERSON  
 CHECKED BY  
 TIMOTHY J. LEE  
 REVISIONS  
 REVISED BY  
 DATE REVISED  
 9-29-21  
 9-29-21  
 9-29-21  
 9-29-21

NOTE:  
 FOR ACCURATE RIGHT OF WAY DATA, CONTACT  
 RIGHT OF WAY ENGINEERING AT THE DISTRICT OFFICE.

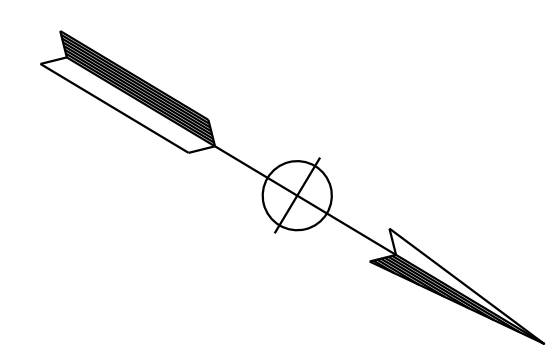

Dist	COUNTY	ROUTE	POST MILES TOTAL PROJECT	SHEET No.	TOTAL SHEETS
04	Ala, CC	680	R11.0/R21.9, R0.0/R0.9	608	1710
			9-29-21		
REGISTERED CIVIL ENGINEER			DATE		
October 8, 2021			PLANS APPROVAL DATE		
<small>THE STATE OF CALIFORNIA OR ITS OFFICERS OR AGENTS SHALL NOT BE RESPONSIBLE FOR THE ACCURACY OR COMPLETENESS OF SCANNED COPIES OF THIS PLAN SHEET.</small>					
WMH CORPORATION 55 South Market St Suite 1200 San Jose, CA 95113			ALAMEDA CTC 1111 Broadway Suite 800 Oakland, CA 94607		

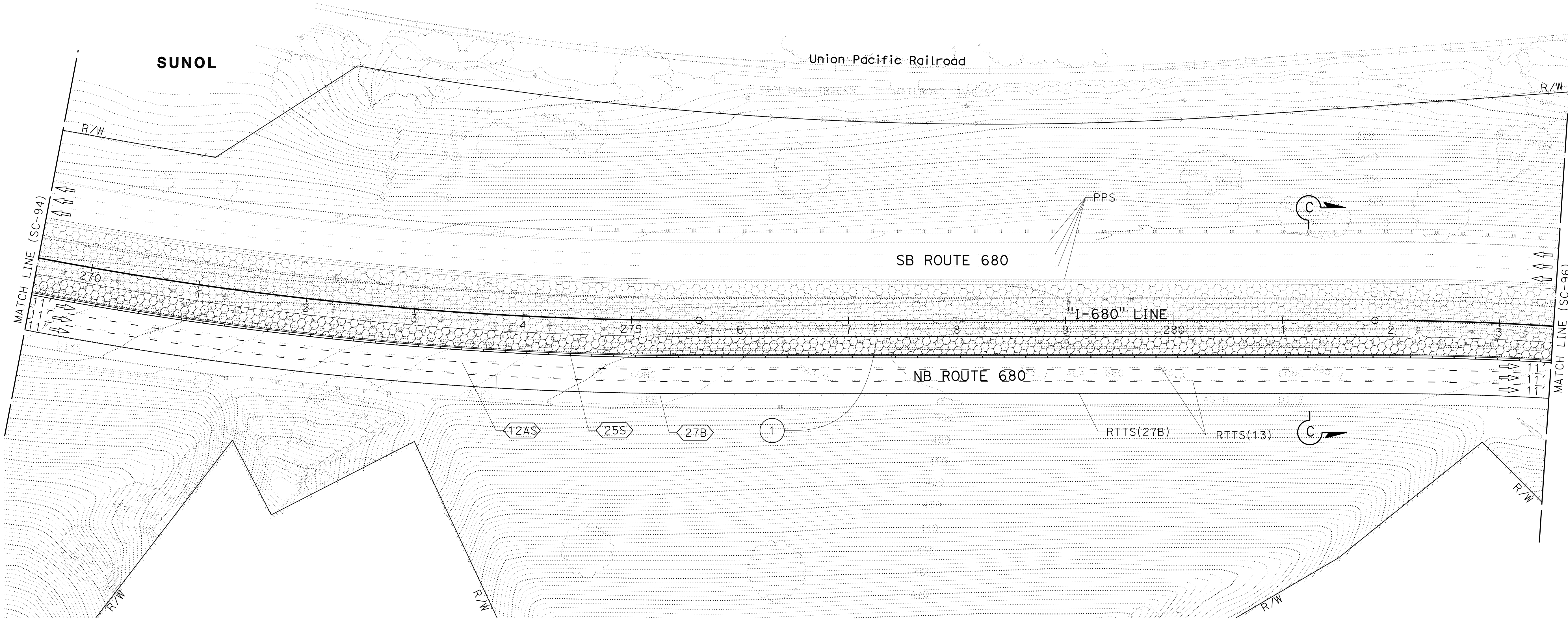

FOR NOTES, ABBREVIATIONS AND  
 LEGEND, SEE SHEET SC-1 AND SC-87

APPROVED FOR STAGE CONSTRUCTION AND TRAFFIC HANDLING WORK ONLY

## STAGE CONSTRUCTION AND TRAFFIC HANDLING PLAN

STAGE 1 PHASE 2B

SCALE: 1" = 50'

**SC-95**

LAST REVISION: DATE PLOTTED => 8-MAR-2022  
 09-29-21 TIME PLOTTED => 10:04

Dist	COUNTY	ROUTE	POST MILES TOTAL PROJECT	SHEET No.	TOTAL SHEETS
04	Ala, CC	680	R11.0/R21.9, RO.0/RO.9	609	1710
			9-29-21		
REGISTERED CIVIL ENGINEER			DATE		
October 8, 2021			PLANS APPROVAL DATE		
WMH CORPORATION 55 South Market St Suite 1200 San Jose, CA 95113			ALAMEDA CTC 1111 Broadway Suite 800 Oakland, CA 94607		

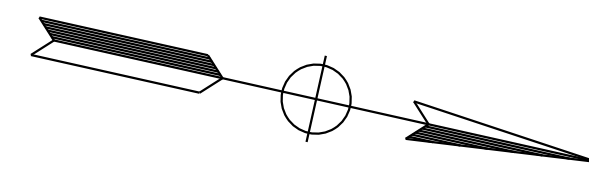

NOTE:  
FOR ACCURATE RIGHT OF WAY DATA, CONTACT  
RIGHT OF WAY ENGINEERING AT THE DISTRICT OFFICE.

REVISOR	DATE	REVISION
JV	9-29-21	
JAMEY VALDIVIA		
ERIN MCPHERSON		
CALCULATED-DESIGNED BY	CHECKED BY	
TIMOTHY J. LEE		
CONSULTANT	FUNCTIONAL SUPERVISOR	
STATE OF CALIFORNIA - DEPARTMENT OF TRANSPORTATION		

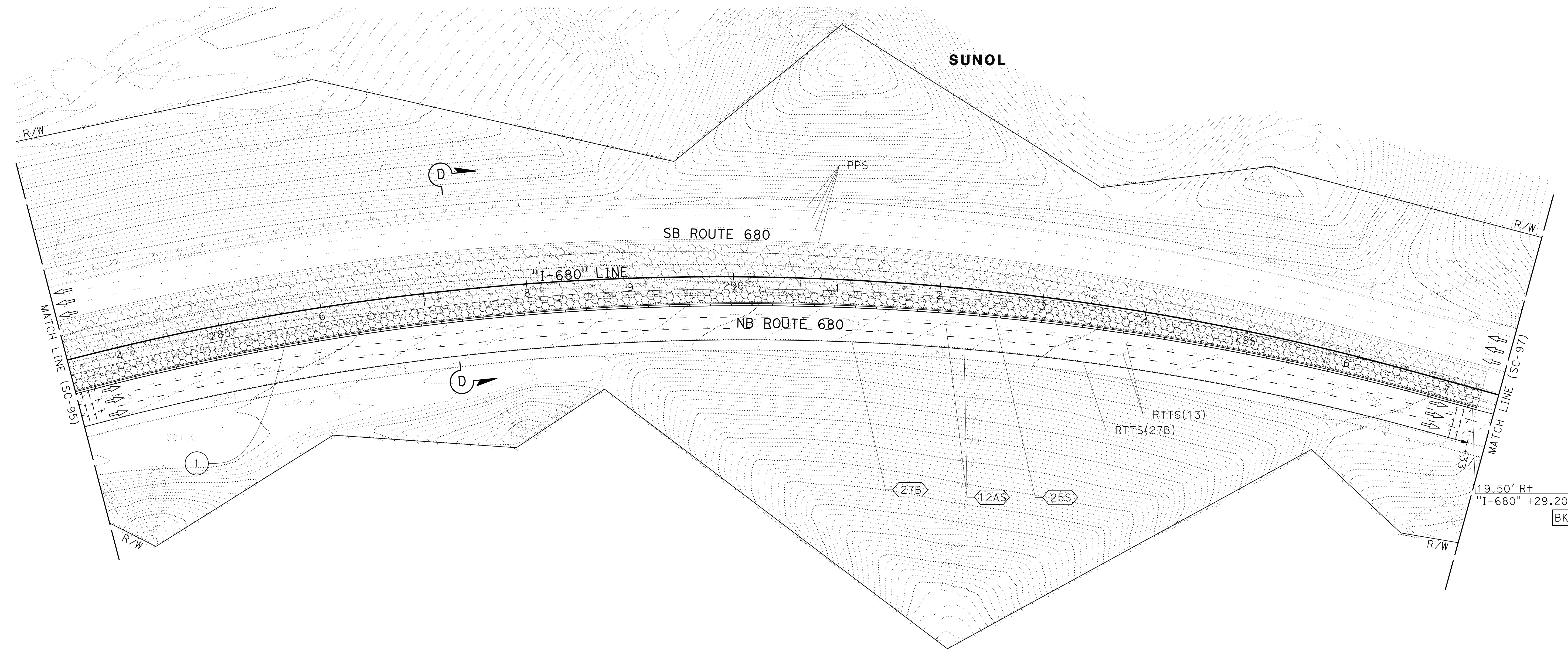

FOR NOTES, ABBREVIATIONS AND  
LEGEND, SEE SHEET SC-1 AND SC-87

**STAGE CONSTRUCTION  
AND TRAFFIC HANDLING PLAN**  
**STAGE 1 PHASE 2B**  
SCALE: 1" = 50'  
**SC-96**

APPROVED FOR STAGE CONSTRUCTION AND TRAFFIC HANDLING WORK ONLY

LAST REVISION: 09-29-21 DATE PLOTTED => 8-MAR-2022 TIME PLOTTED => 10:04

NOTE:  
FOR ACCURATE RIGHT OF WAY DATA, CONTACT  
RIGHT OF WAY ENGINEERING AT THE DISTRICT OFFICE.

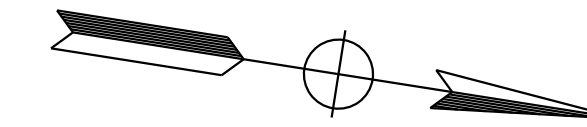

Dist	COUNTY	ROUTE	POST MILES TOTAL PROJECT	SHEET No.	TOTAL SHEETS
04	Ala, CC	680	R11.0/R21.9, RO.0/RO.9	610	1710

 REGISTERED CIVIL ENGINEER	9-29-21 DATE
October 8, 2021 PLANS APPROVAL DATE	

  

ERIN D. McPHERSON No. C91111 Exp 3-31-24 CIVIL STATE OF CALIFORNIA
--------------------------------------------------------------------------------

WMH CORPORATION 55 South Market St Suite 1200 San Jose, CA 95113	ALAMEDA CTC 1111 Broadway Suite 800 Oakland, CA 94607
---------------------------------------------------------------------------	----------------------------------------------------------------

STATE OF CALIFORNIA - DEPARTMENT OF TRANSPORTATION	CONSULTANT FUNCTIONAL SUPERVISOR	REVISIONS
	TIMOTHY J. LEE	REVISED BY: JAMIE VALDIVIA DATE: 9-29-21 CHECKED BY: ERIN McPHERSON DESIGNED BY: ERIN McPHERSON

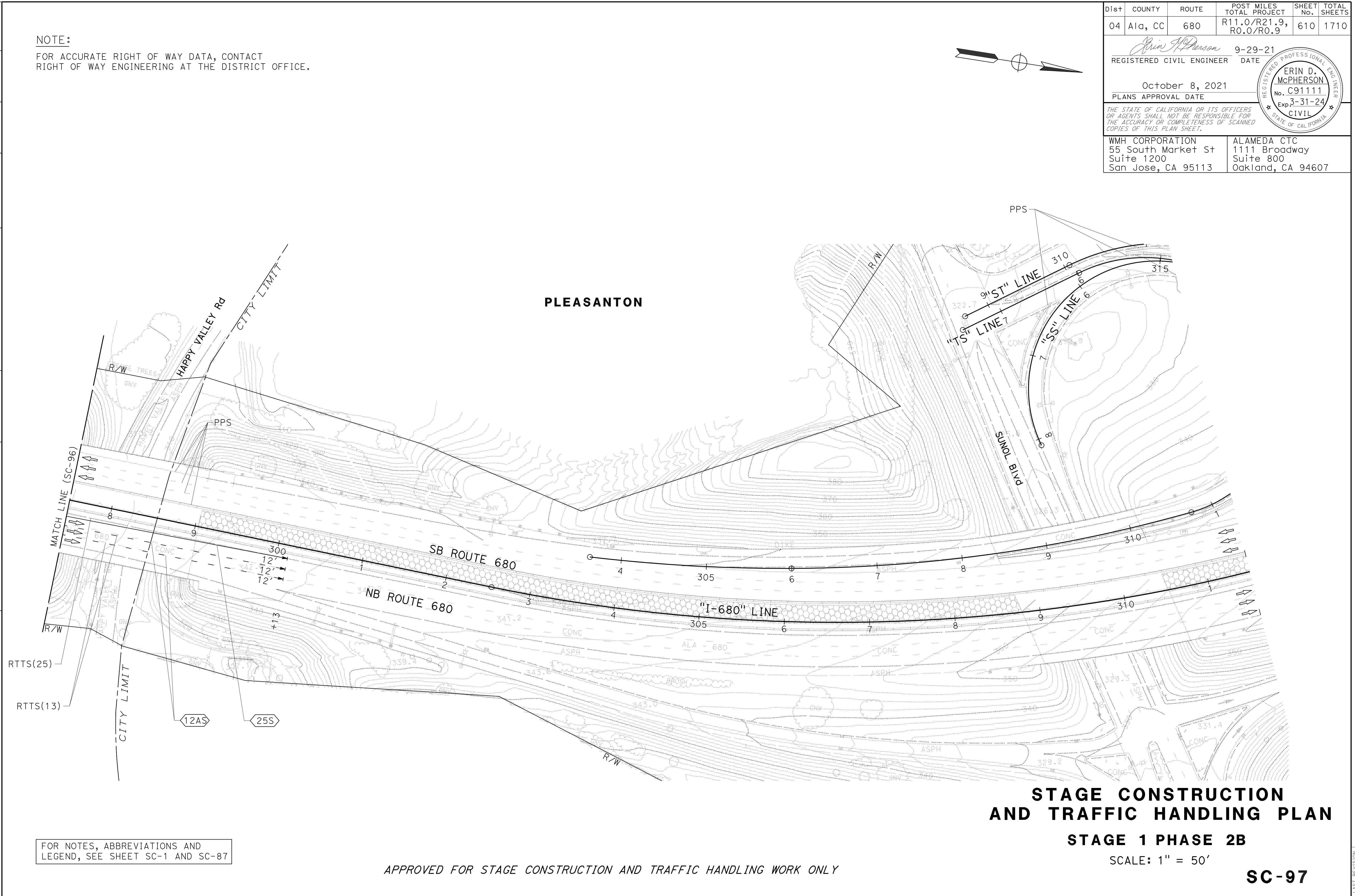

**STAGE CONSTRUCTION  
AND TRAFFIC HANDLING PLAN**  
**STAGE 1 PHASE 2B**  
 SCALE: 1" = 50'  
**SC-97**

FOR NOTES, ABBREVIATIONS AND  
LEGEND, SEE SHEET SC-1 AND SC-87

APPROVED FOR STAGE CONSTRUCTION AND TRAFFIC HANDLING WORK ONLY

LAST REVISION: DATE PLOTTED => 8-MAR-2022  
 09-29-21 TIME PLOTTED => 10:04

Dist	COUNTY	ROUTE	POST MILES TOTAL PROJECT	SHEET No.	TOTAL SHEETS
04	Ala, CC	680	R11.0/R21.9, RO.0/RO.9	611	1710
			9-29-21		
REGISTERED CIVIL ENGINEER			DATE		
October 8, 2021			PLANS APPROVAL DATE		
WMH CORPORATION 55 South Market St Suite 1200 San Jose, CA 95113			ALAMEDA CTC 1111 Broadway Suite 800 Oakland, CA 94607		

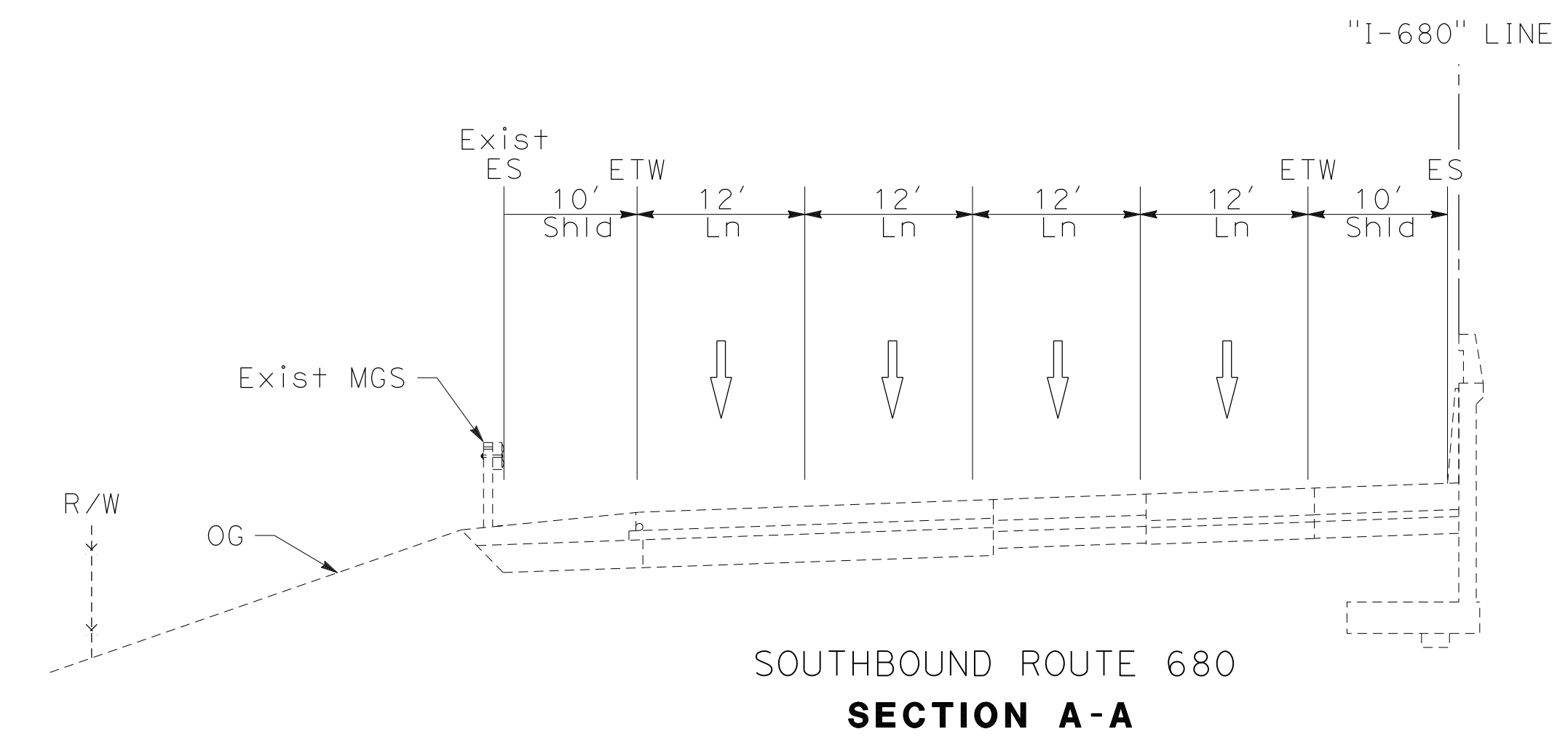
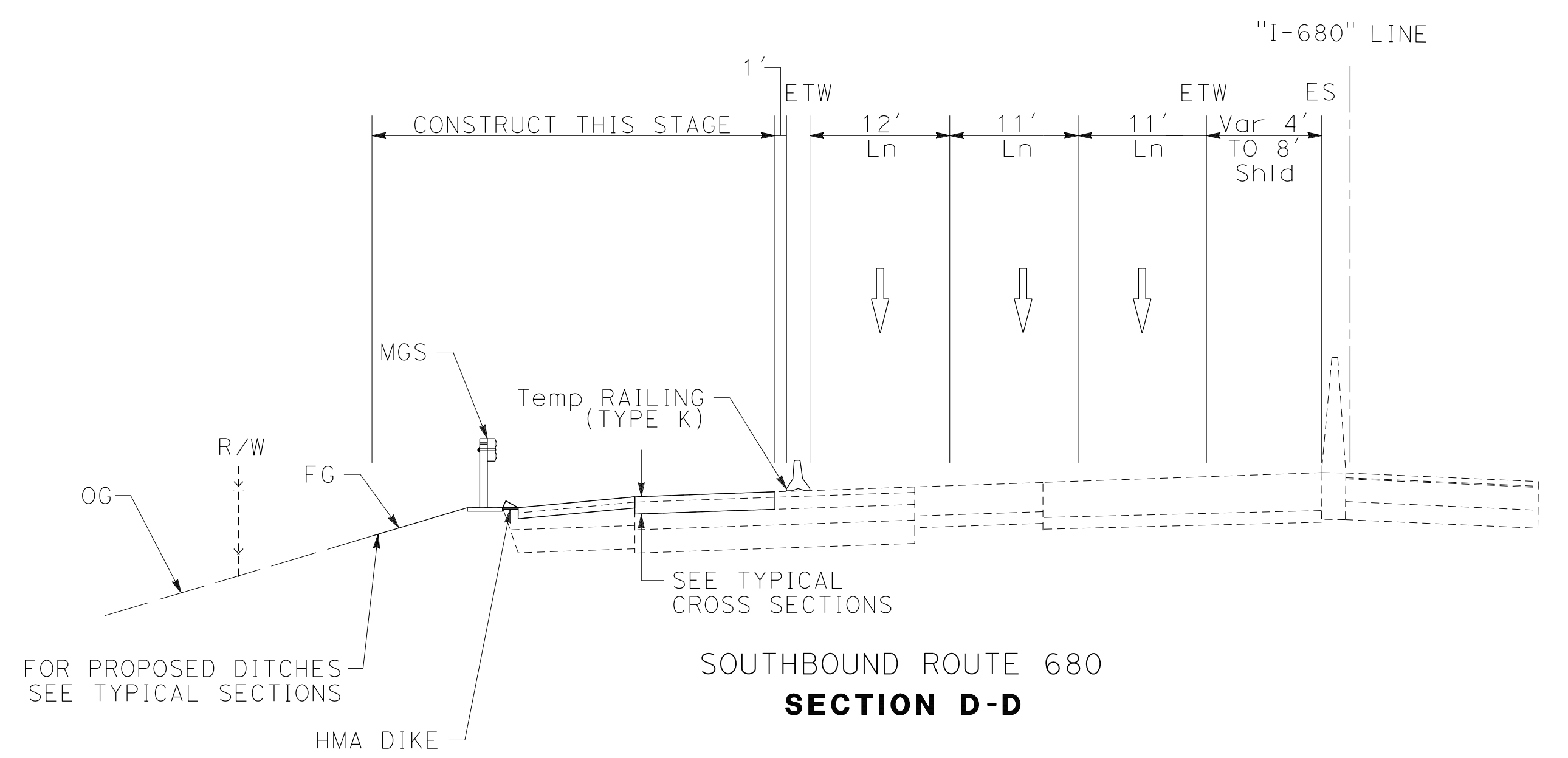
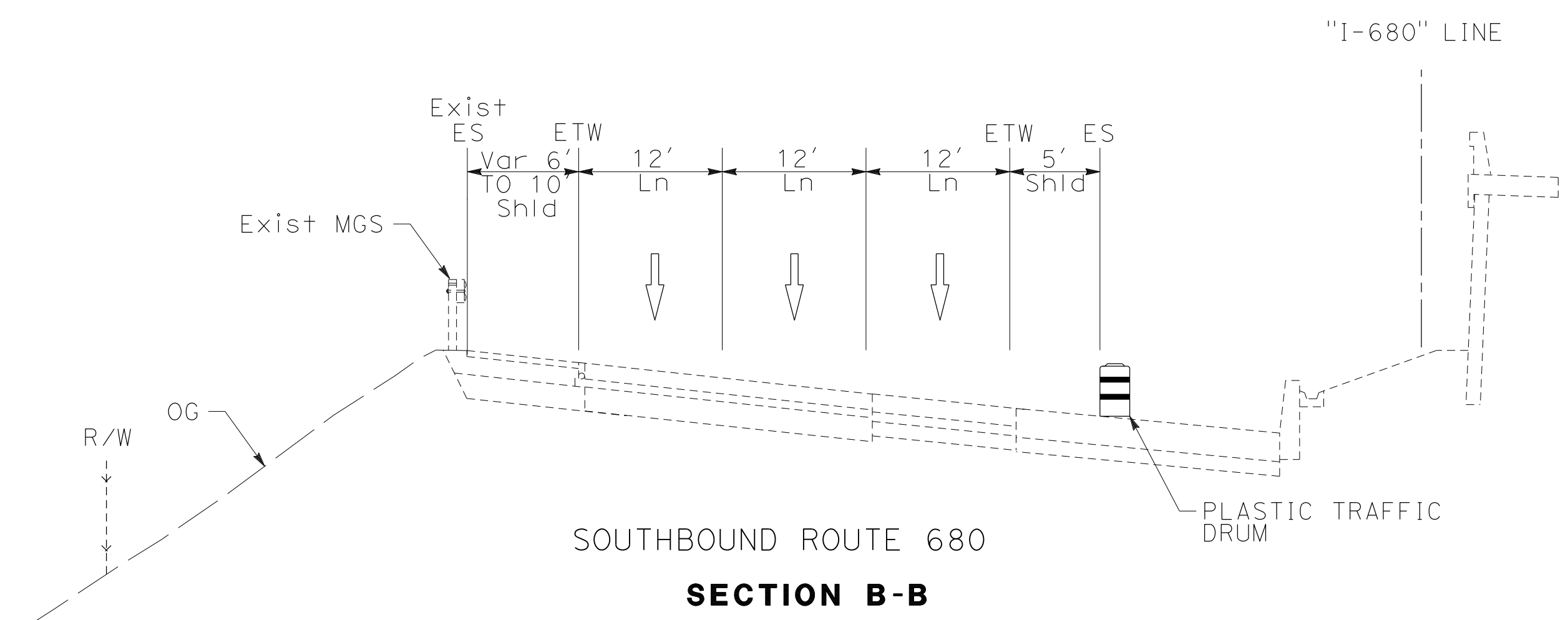
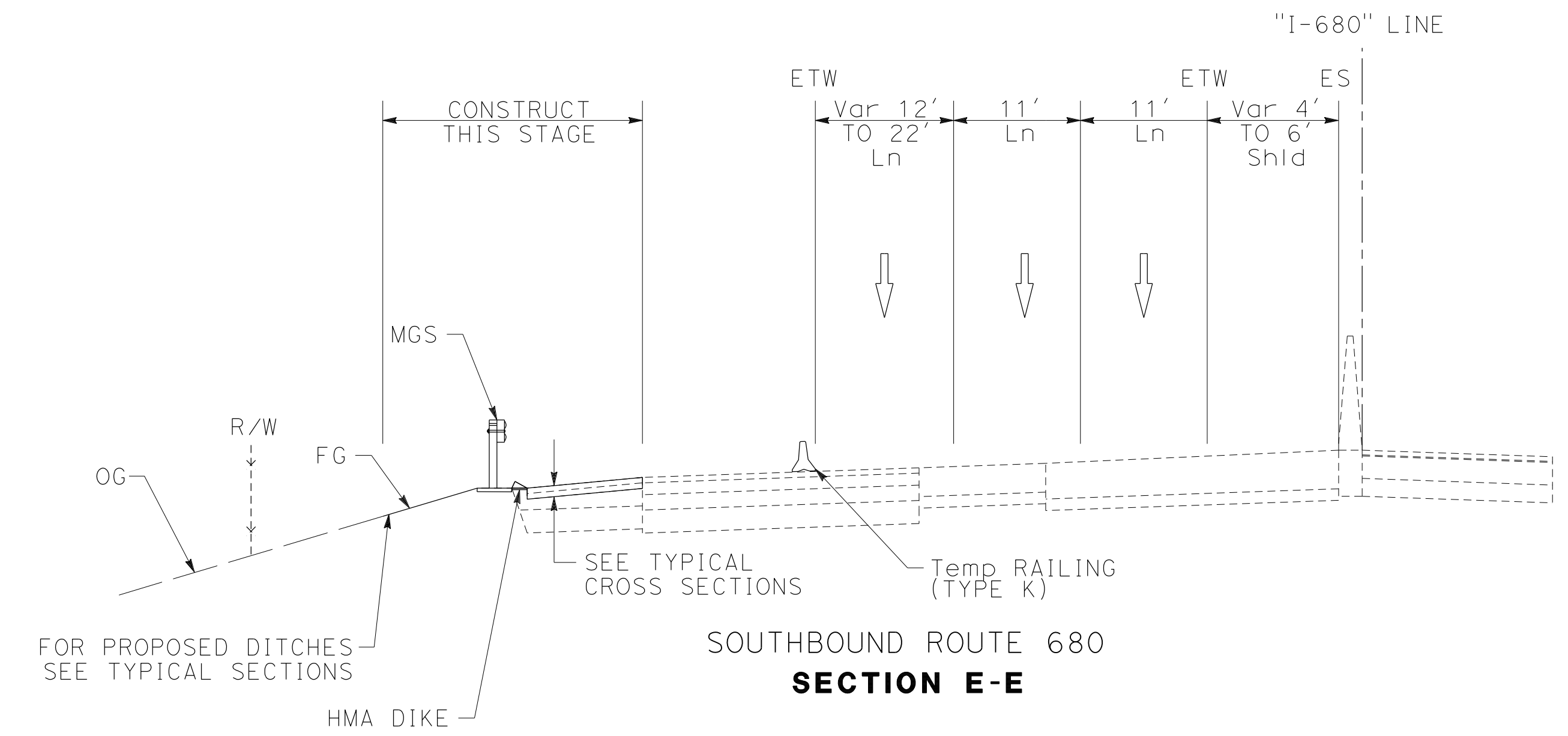
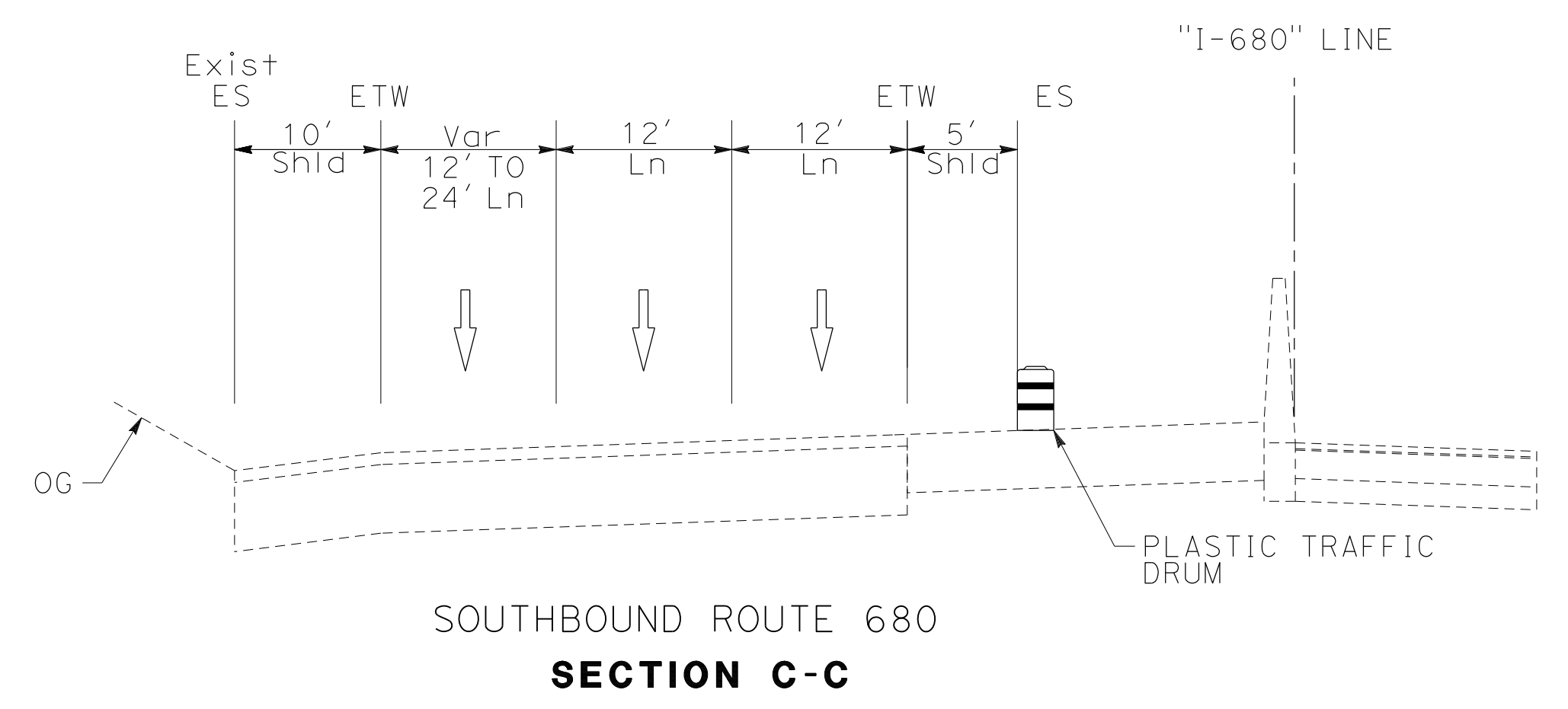

**STAGE CONSTRUCTION AND TRAFFIC HANDLING PLAN STAGE 2**

NO SCALE

**SC-98**

FOR NOTES, ABBREVIATIONS AND LEGEND, SEE SHEET SC-1 AND SC-102

X:\680\_SB\_GAP\_EXPRESS\000\_CADD\Submittal\1\1\CADD\_submittal\0420000235ma098.dgn  
 STATE OF CALIFORNIA - DEPARTMENT OF TRANSPORTATION  
 CONSULTANT FUNCTIONAL SUPERVISOR  
 JAMEY VALDIVIA  
 ERIN MCPHERSON  
 CALCULATED-DESIGNED BY  
 CHECKED BY  
 TIMOTHY J. LEE  
 REVISIONS  
 REVISION NO. DATE BY  
 1 09-29-21 JV



Dist	COUNTY	ROUTE	POST MILES TOTAL PROJECT	SHEET No.	TOTAL SHEETS
04	Ala, CC	680	R11.0/R21.9, RO.0/RO.9	613	1710
			9-29-21		
REGISTERED CIVIL ENGINEER			DATE		
October 8, 2021			PLANS APPROVAL DATE		
THE STATE OF CALIFORNIA OR ITS OFFICERS OR AGENTS SHALL NOT BE RESPONSIBLE FOR THE ACCURACY OR COMPLETENESS OF SCANNED COPIES OF THIS PLAN SHEET.					
WMH CORPORATION 55 South Market St Suite 1200 San Jose, CA 95113			ALAMEDA CTC 1111 Broadway Suite 800 Oakland, CA 94607		

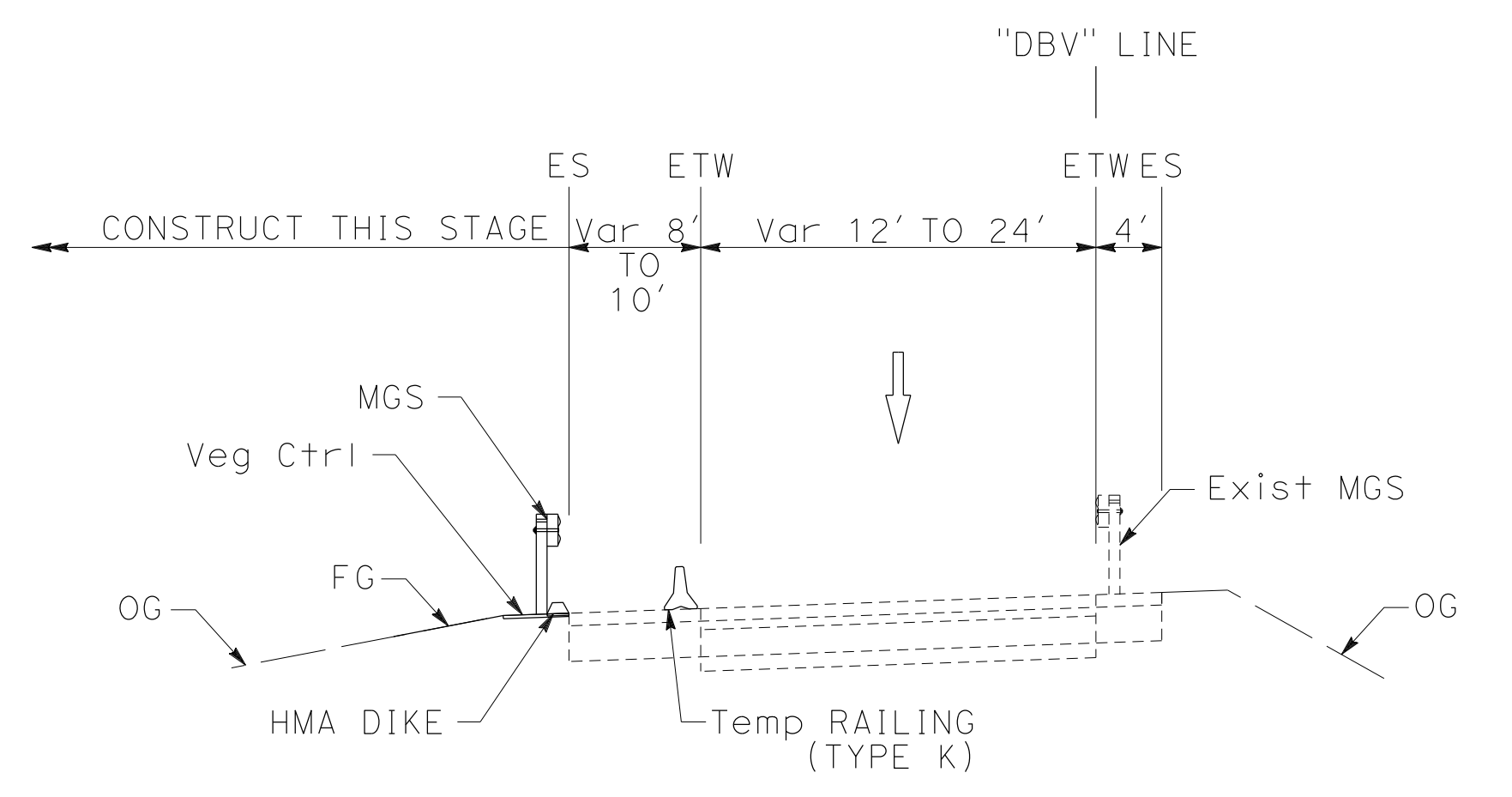

SB ROUTE 680 OFF RAMP TO AMADOR PLAZA Rd  
**SECTION M-M**

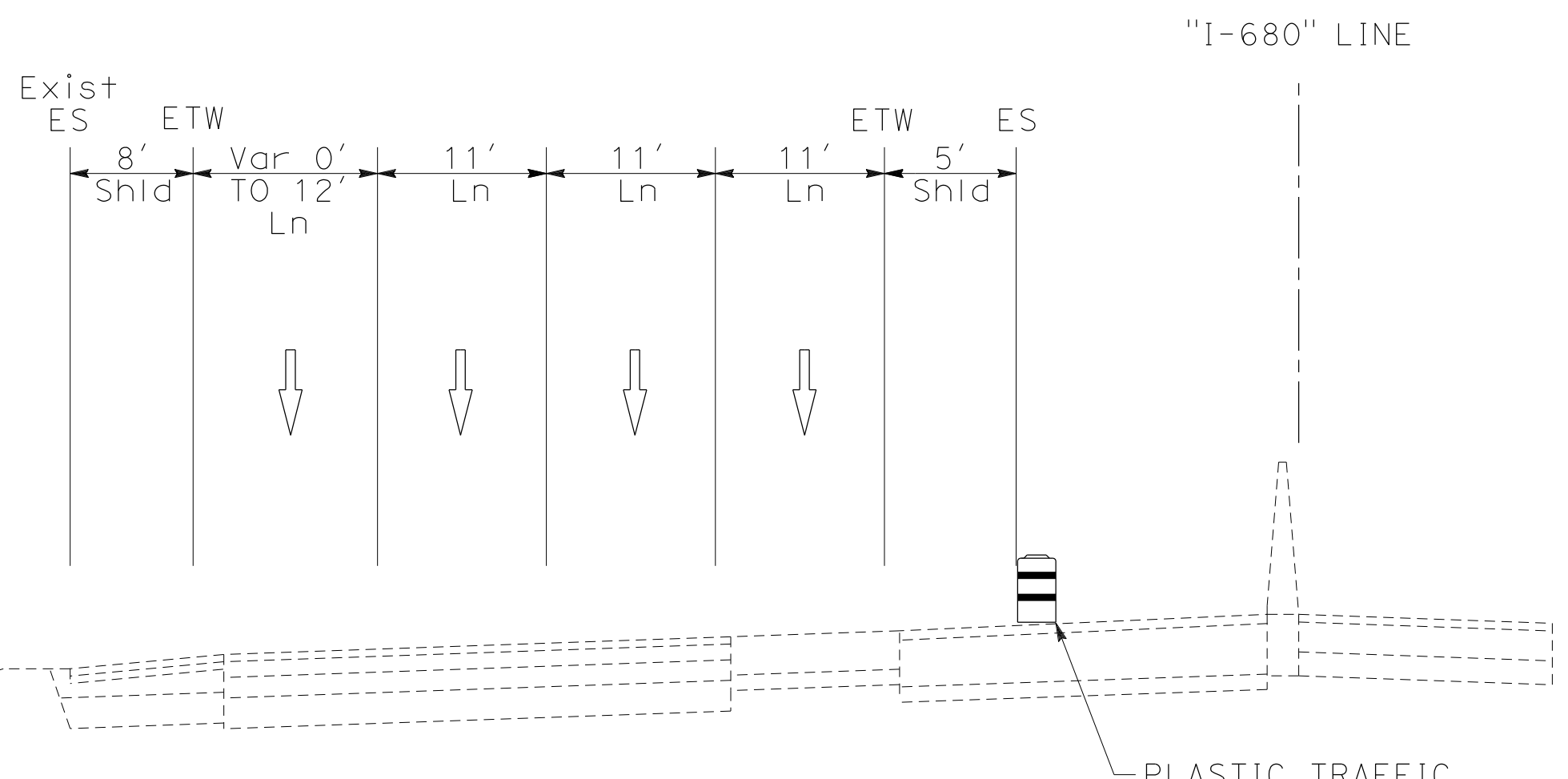

SOUTHBOUND ROUTE 680  
**SECTION L-L**

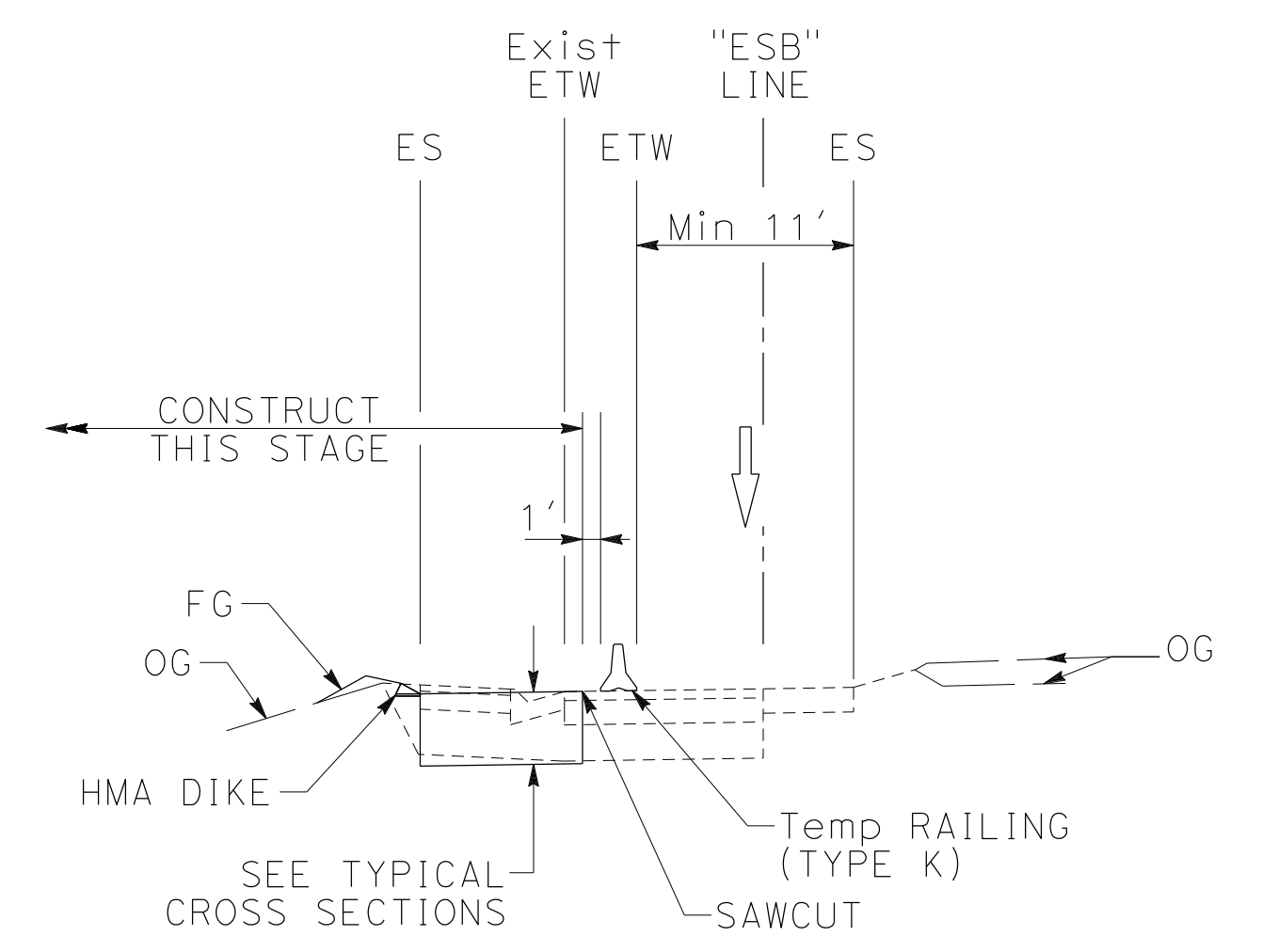

EB ROUTE 580 OFF RAMP TO SB ROUTE 680  
**SECTION K-K**

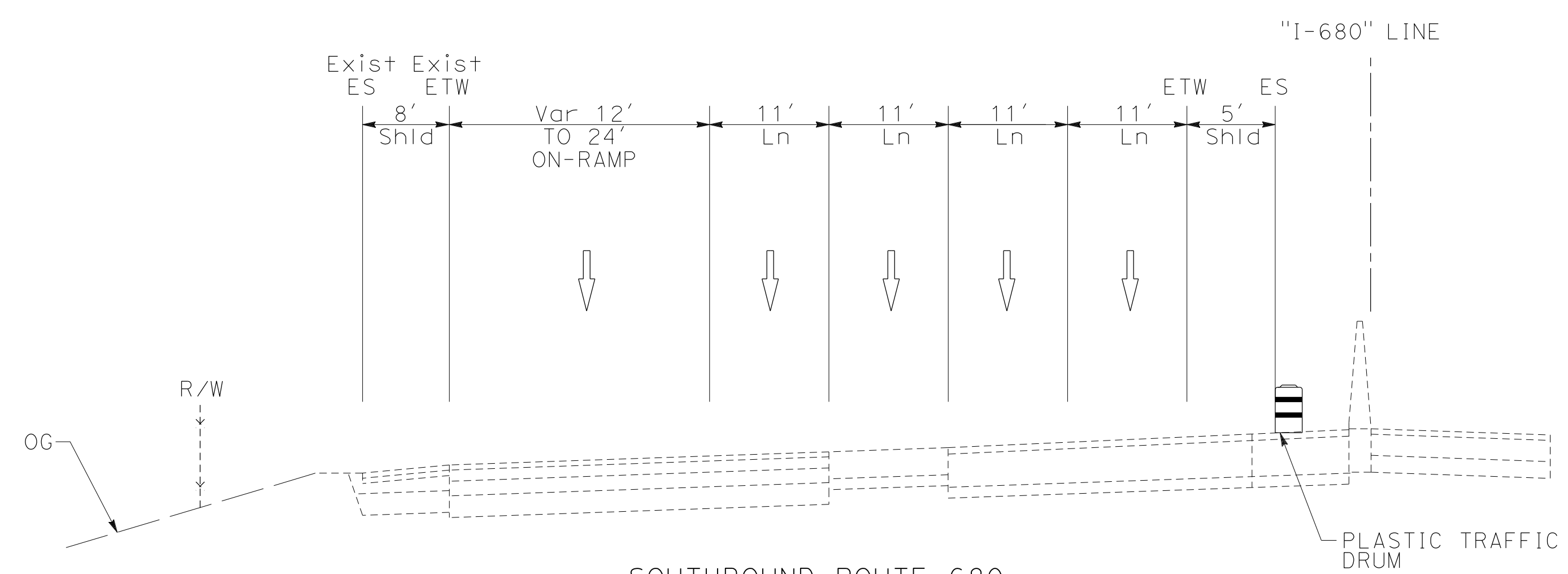

SOUTHBOUND ROUTE 680  
**SECTION O-O**

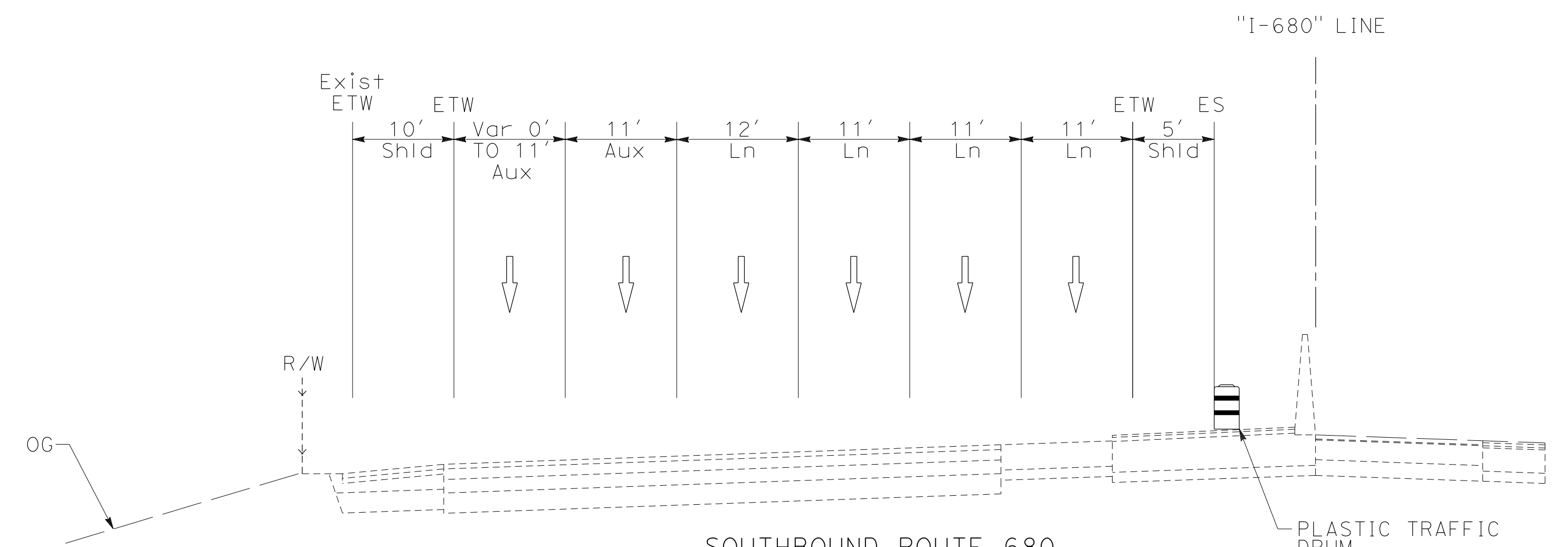

SOUTHBOUND ROUTE 680  
**SECTION N-N**

**STAGE CONSTRUCTION AND TRAFFIC HANDLING PLAN STAGE 2**

NO SCALE

**SC-100**

FOR NOTES, ABBREVIATIONS AND LEGEND, SEE SHEET SC-1 AND SC-102

X:\680\_SB\_GAP\_EXPRESS\000\_CADD\_Submit\10420000235ma100.dgn  
 STATE OF CALIFORNIA - DEPARTMENT OF TRANSPORTATION  
 CONSULTANT: FUNCTIONAL SUPERVISOR: JAMEY VALDIVIA  
 CHECKED BY: ERIN MCPHERSON  
 SUPERVISOR: TIMOTHY J. LEE  
 DESIGNED BY: JAV  
 DATE REVISED: 9-29-21  
 REVISIONS:

Dist	COUNTY	ROUTE	POST MILES TOTAL PROJECT	SHEET No.	TOTAL SHEETS
04	Ala, CC	680	R11.0/R21.9, R0.0/R0.9	614	1710
			9-29-21		
REGISTERED CIVIL ENGINEER			DATE		
October 8, 2021			PLANS APPROVAL DATE		
WMH CORPORATION 55 South Market St Suite 1200 San Jose, CA 95113			ALAMEDA CTC 1111 Broadway Suite 800 Oakland, CA 94607		

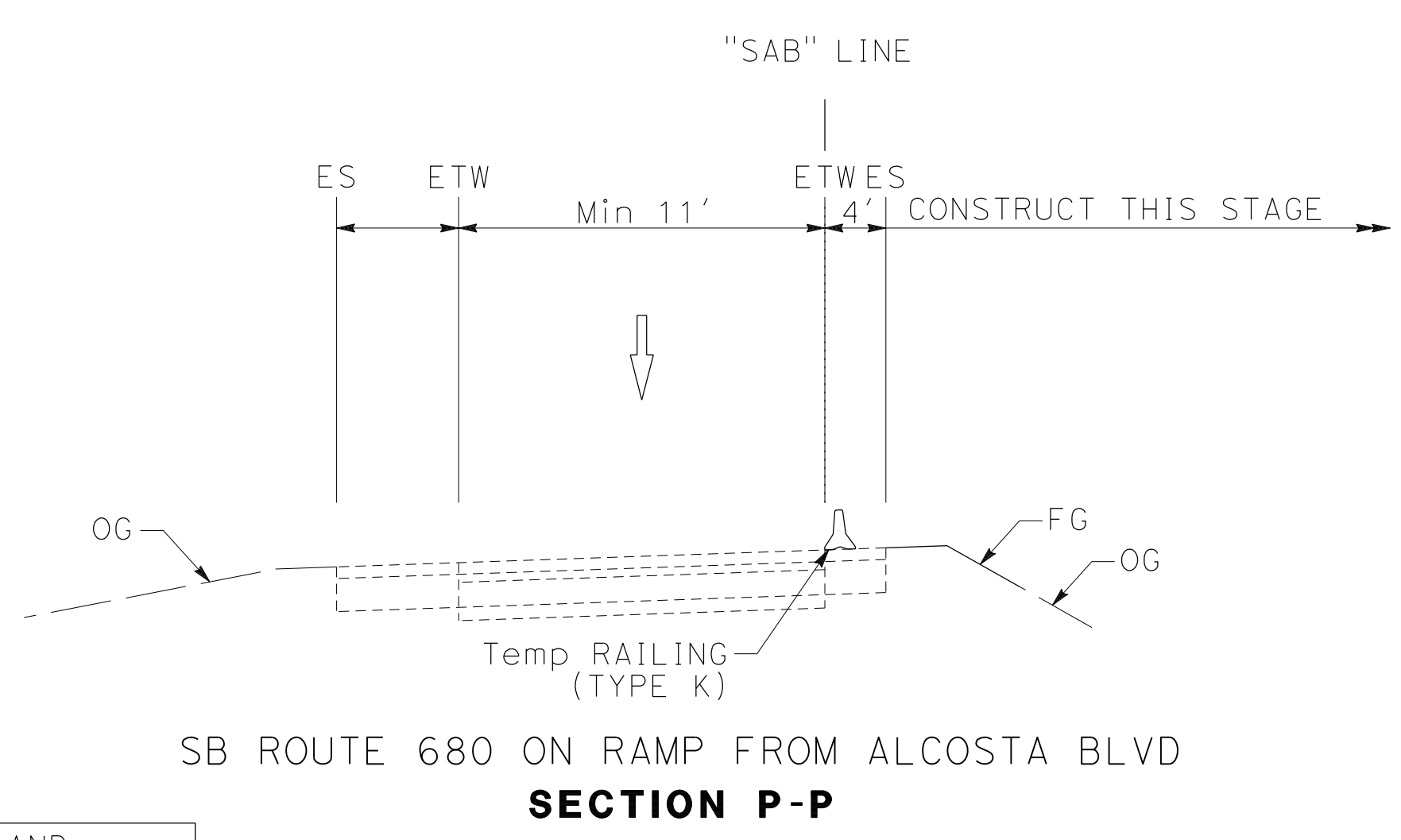
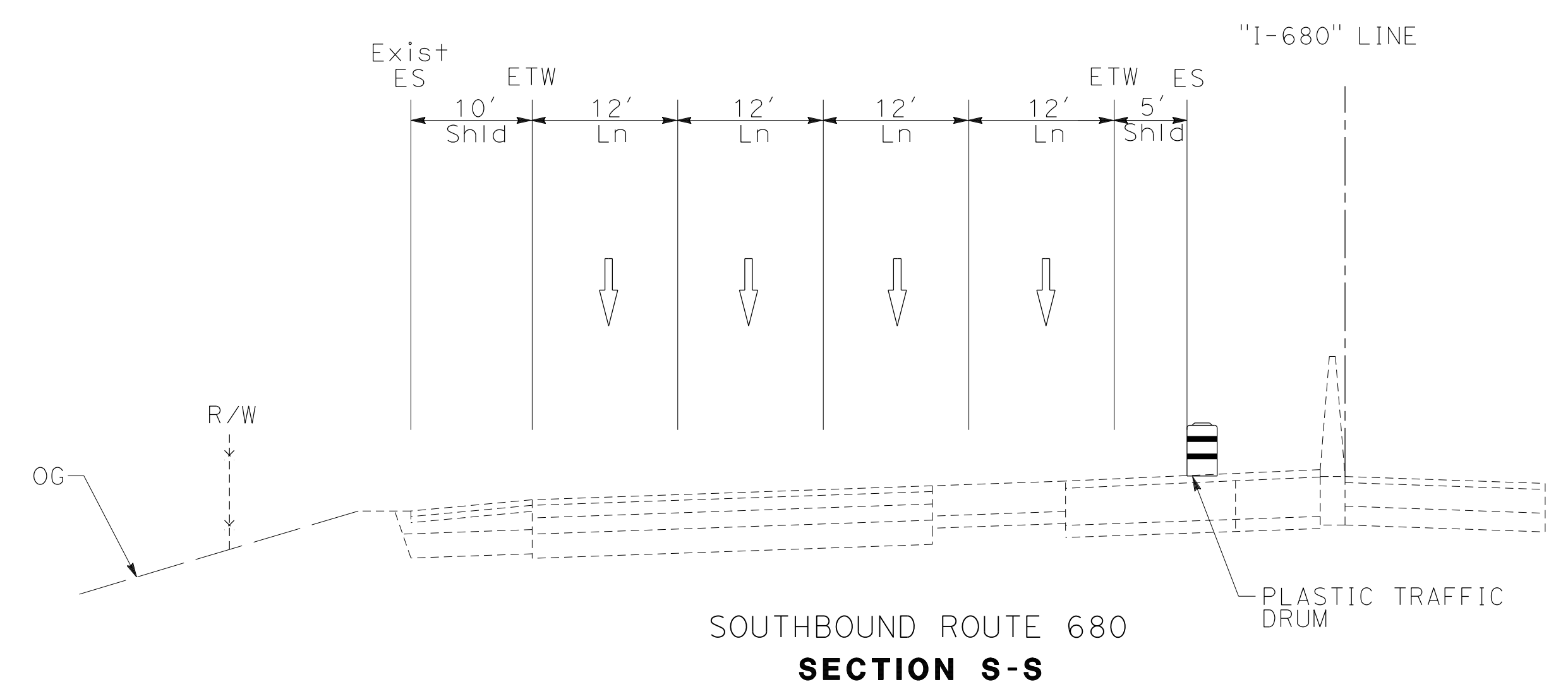
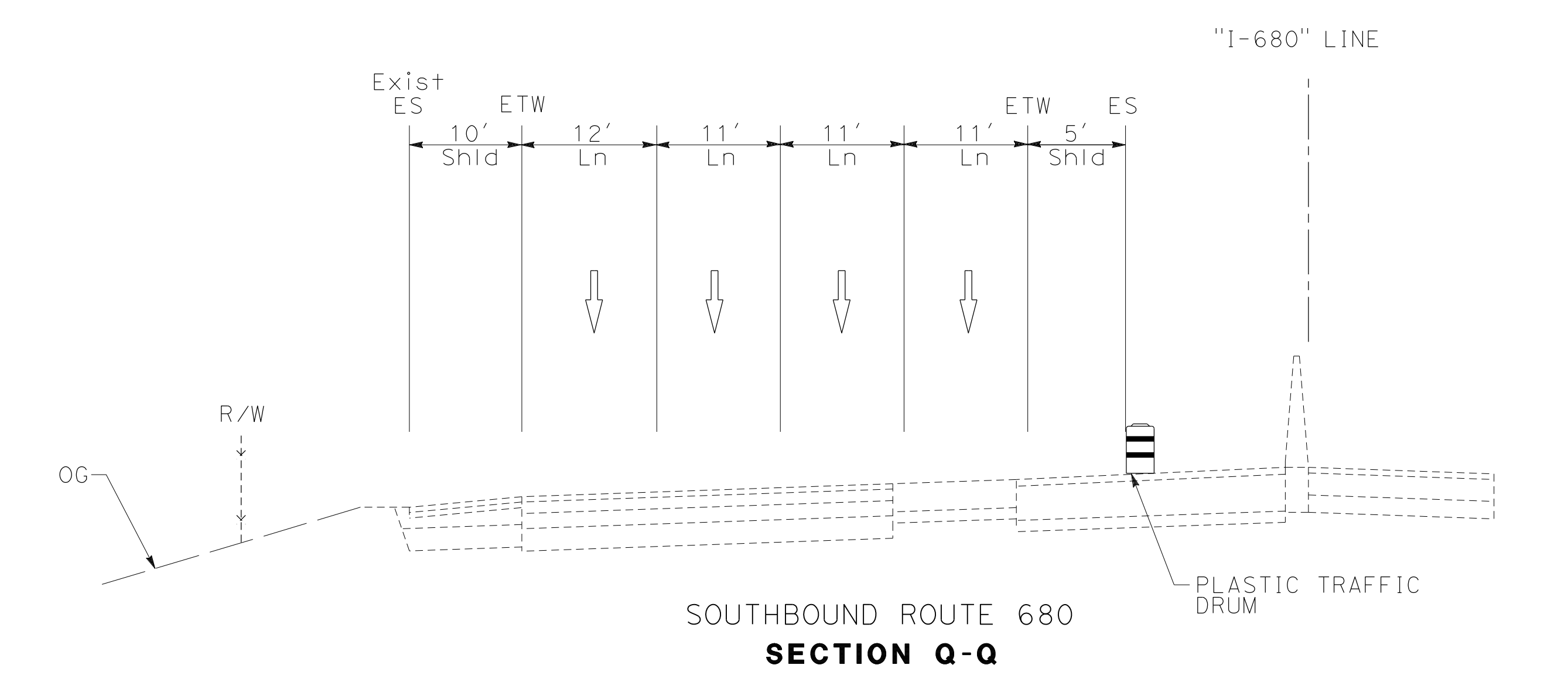
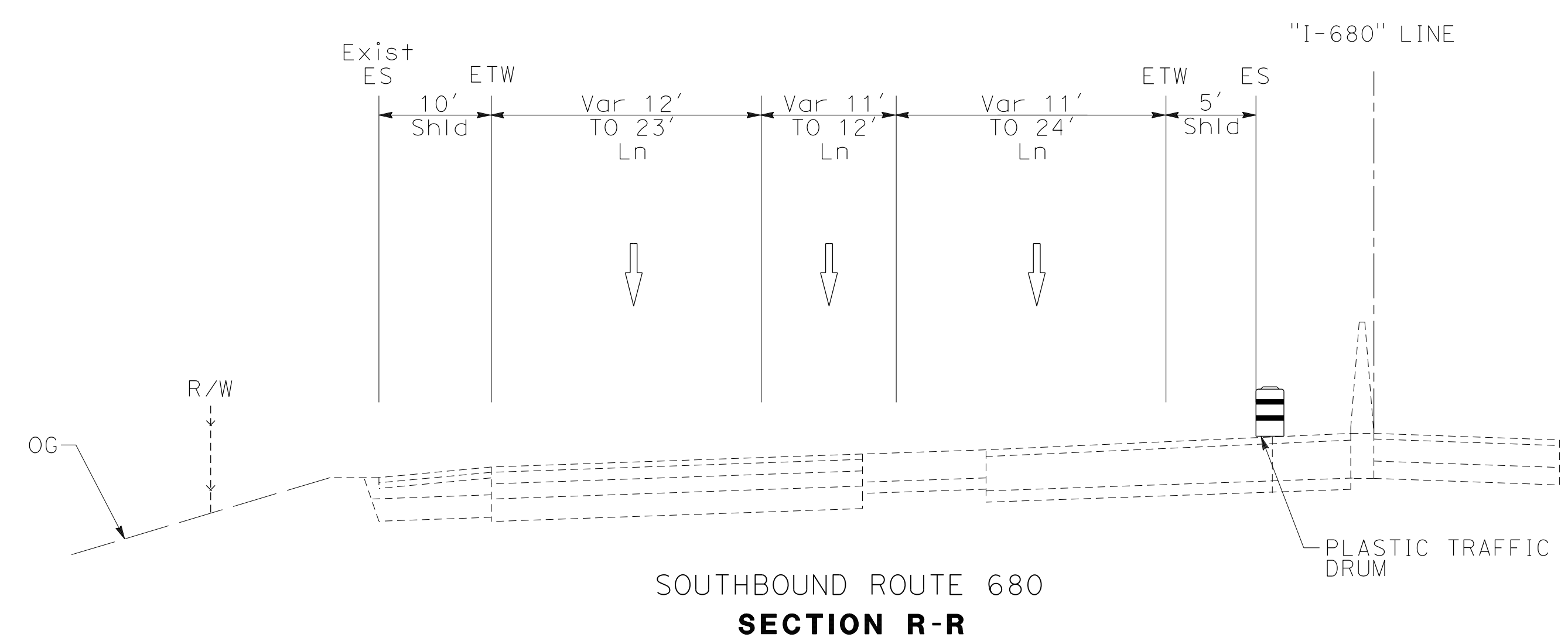

FOR NOTES, ABBREVIATIONS AND LEGEND, SEE SHEET SC-1 AND SC-102

## STAGE CONSTRUCTION AND TRAFFIC HANDLING PLAN STAGE 2

NO SCALE

**SC-101**

X:\680\_SB\_EXPRESS\000\_CAD\Submittal\11\11\CADD\_submittal\0420000235ma101.dgn  
 STATE OF CALIFORNIA - DEPARTMENT OF TRANSPORTATION  
 CONSULTANT: JAMEY VALDIVIA  
 SUPERVISOR: TIMOTHY J. LEE  
 DESIGNED BY: JAMEY VALDIVIA  
 CHECKED BY: ERIN MCPHERSON  
 REVISIONS: JV 9-29-21

Dist	COUNTY	ROUTE	POST MILES TOTAL PROJECT	SHEET No.	TOTAL SHEETS
04	Ala, CC	680	R11.0/R21.9, RO.0/RO.9	615	1710
			9-29-21		
REGISTERED CIVIL ENGINEER			DATE		
October 8, 2021			PLANS APPROVAL DATE		
WMH CORPORATION			ALAMEDA CTC		
55 South Market St			1111 Broadway		
Suite 1200			Suite 800		
San Jose, CA 95113			Oakland, CA 94607		

**NOTES:**

- FOR ACCURATE RIGHT OF WAY DATA, CONTACT RIGHT OF WAY ENGINEERING AT THE DISTRICT OFFICE.
- PAVEMENT REHABILITATION SHOWN IN STAGE 3 CAN BE DONE CONCURRENTLY WITH STAGE 2 FROM APPROXIMATELY STA "I-680" 162+00 TO 330+00 AND STA "I-680" 540+00 TO 685+00.

**STAGE 2 CONSTRUCTION:**

- CONSTRUCT MGS, PROPOSED DRAINAGE, GRADING, AND PAVEMENT REHABILITATION ON SHOULDER AND EXTERIOR LANE.
- CONSTRUCT MGS, PROPOSED DRAINAGE, GRADING, AND SHOULDER REHABILITATION.
- CONSTRUCT MVP.
- CONSTRUCT PROPOSED DRAINAGE AND GRADING.

**STAGE 2 TRAFFIC:**

- SHIFT SOUTHBOUND 680 TRAFFIC TOWARD THE MEDIAN.
- MAINTAIN EXISTING LANE NUMBER THROUGH WORK AREA.

**STAGE 2 DRAINAGE:**

CONSTRUCT DRAINAGE SYSTEMS ALONG L+ ES AND WITHIN WORK AREA  
 ALONG STA "I-680" 345+00 TO "I-680" 370+00  
 ALONG STA "I-680" 378+00 TO "I-680" 386+00  
 ALONG STA "I-680" 390+00 TO "I-680" 509+00  
 ALONG STA "I-680" 526+00 TO "I-680" 531+00  
 ALONG STA "I-680" 552+20 TO "ESB" 564+00  
 ALONG STA "DBV" 572+80 TO "DBV" 576+00

CONSTRUCT DRAINAGE SYSTEMS ALONG R+ ES AND WITHIN WORK AREA  
 ALONG STA "SAB" 656+00 TO "SAB" 658+00

CONSTRUCT DRAINAGE SYSTEMS AS SHOWN ALONG ALCOSTA BLVD, AS WELL AS SYSTEM

STATE OF CALIFORNIA - DEPARTMENT OF TRANSPORTATION	CONSULTANT	FUNCTIONAL SUPERVISOR	CALCULATED/DESIGNED BY	REVISOR	DATE
	JAMEY VALDIVIA	TIMOTHY J. LEE	ERIN MCPHERSON	JV	9-29-21
	ERIN MCPHERSON				

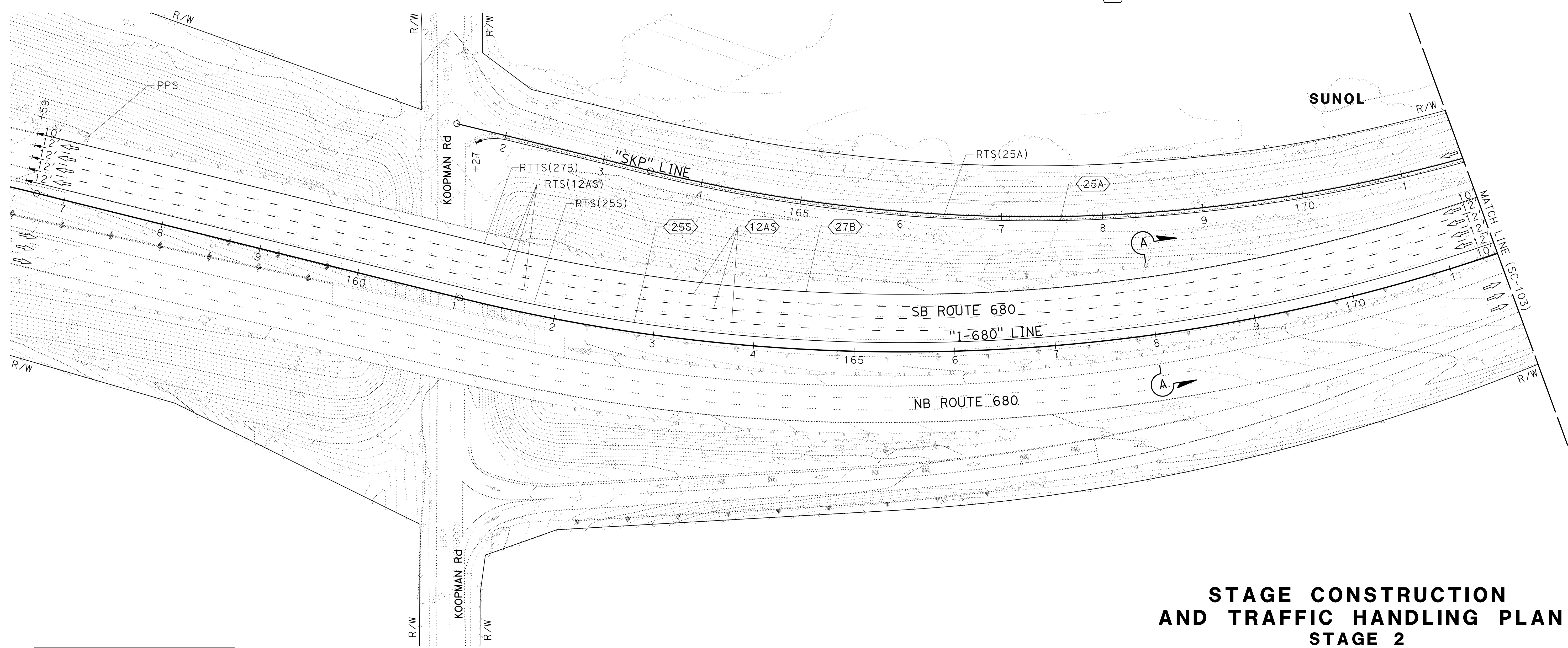

FOR NOTES, ABBREVIATIONS AND LEGEND, SEE SHEET SC-1

APPROVED FOR STAGE CONSTRUCTION AND TRAFFIC HANDLING WORK ONLY

**STAGE CONSTRUCTION AND TRAFFIC HANDLING PLAN STAGE 2**

SCALE: 1" = 50'

**SC-102**

Dist	COUNTY	ROUTE	POST MILES TOTAL PROJECT	SHEET No.	TOTAL SHEETS
04	Ala, CC	680	R11.0/R21.9, RO.0/RO.9	616	1710

<i>Erin D. McPherson</i>	9-29-21
REGISTERED CIVIL ENGINEER	DATE
October 8, 2021	
PLANS APPROVAL DATE	

  

THE STATE OF CALIFORNIA OR ITS OFFICERS OR AGENTS SHALL NOT BE RESPONSIBLE FOR THE ACCURACY OR COMPLETENESS OF SCANNED COPIES OF THIS PLAN SHEET.	<b>ERIN D. McPHERSON</b> No. C91111 Exp. 3-31-24 CIVIL
---------------------------------------------------------------------------------------------------------------------------------------------------	-----------------------------------------------------------------

  

WMH CORPORATION 55 South Market St Suite 1200 San Jose, CA 95113	ALAMEDA CTC 1111 Broadway Suite 800 Oakland, CA 94607
---------------------------------------------------------------------------	----------------------------------------------------------------

NOTE:  
 FOR ACCURATE RIGHT OF WAY DATA, CONTACT RIGHT OF WAY ENGINEERING AT THE DISTRICT OFFICE.

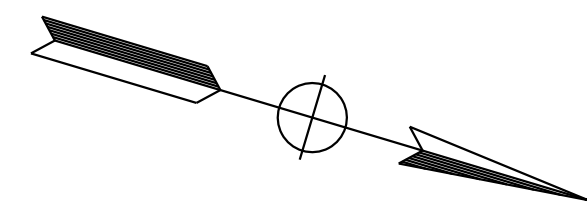

DESIGNED BY	JV
DATE	9-29-21
REVISOR	
DATE	
CALCULATED-DRAWN BY	JAMEY VALDIVIA
CHECKED BY	ERIN McPHERSON
CONSULTANT SUPERVISOR	TIMOTHY J. LEE
STATE OF CALIFORNIA - DEPARTMENT OF TRANSPORTATION	

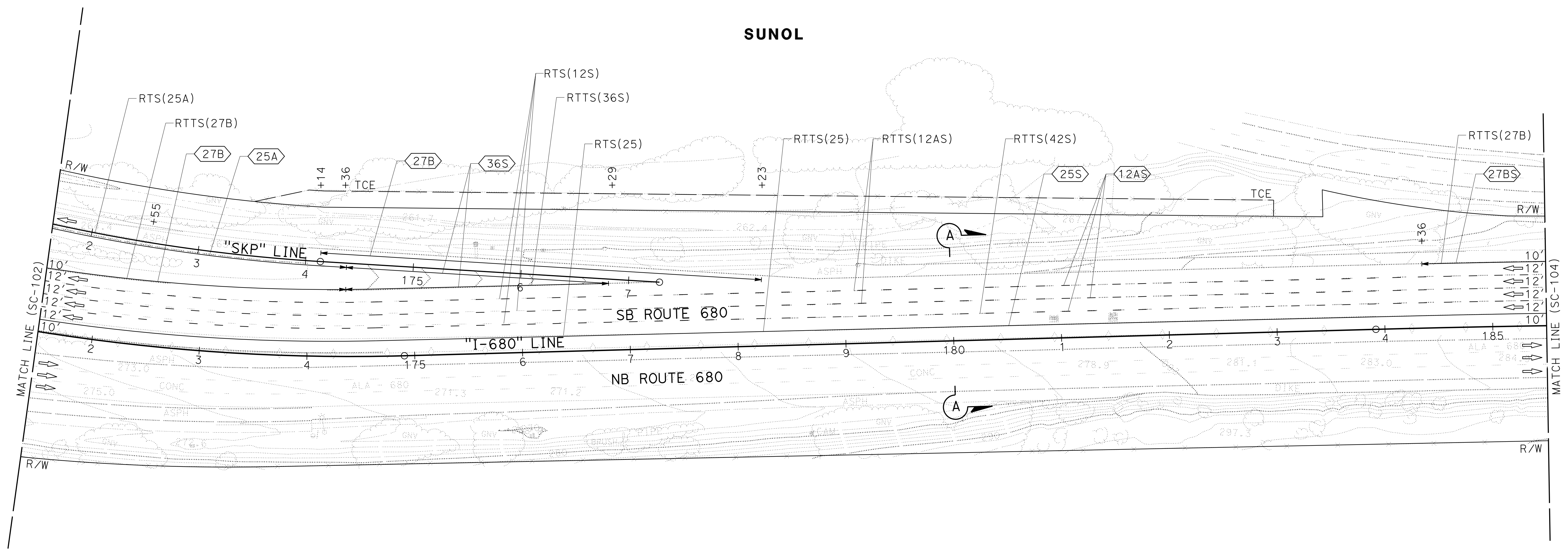

FOR NOTES, ABBREVIATIONS AND LEGEND, SEE SHEET SC-1 AND SC-102

APPROVED FOR STAGE CONSTRUCTION AND TRAFFIC HANDLING WORK ONLY

**STAGE CONSTRUCTION AND TRAFFIC HANDLING PLAN**  
**STAGE 2**

SCALE: 1" = 50'

**SC-103**

Dist	COUNTY	ROUTE	POST MILES TOTAL PROJECT	SHEET No.	TOTAL SHEETS
04	Ala, CC	680	R11.0/R21.9, R0.0/R0.9	617	1710
			9-29-21		
REGISTERED CIVIL ENGINEER			DATE		
October 8, 2021			PLANS APPROVAL DATE		
<small>THE STATE OF CALIFORNIA OR ITS OFFICERS OR AGENTS SHALL NOT BE RESPONSIBLE FOR THE ACCURACY OR COMPLETENESS OF SCANNED COPIES OF THIS PLAN SHEET.</small>					
WMH CORPORATION 55 South Market St Suite 1200 San Jose, CA 95113			ALAMEDA CTC 1111 Broadway Suite 800 Oakland, CA 94607		

NOTE:  
FOR ACCURATE RIGHT OF WAY DATA, CONTACT RIGHT OF WAY ENGINEERING AT THE DISTRICT OFFICE.

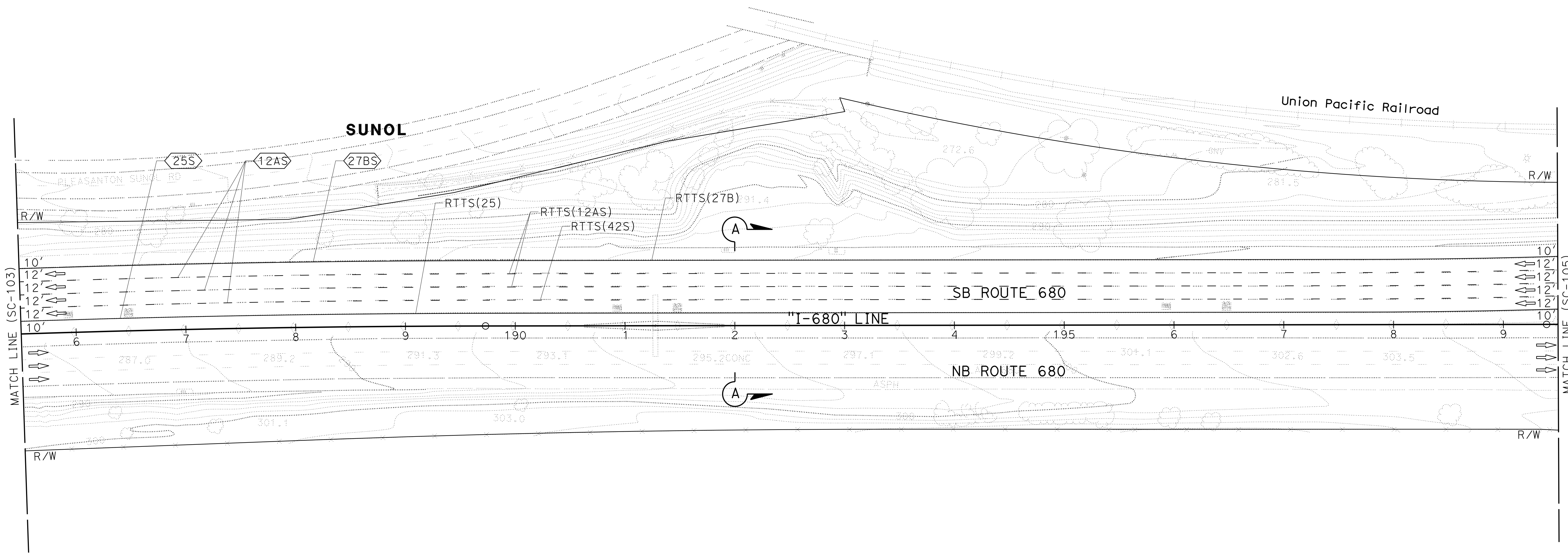
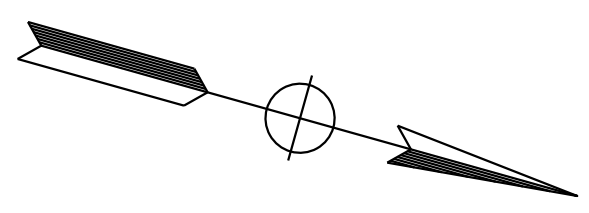

0:\0030\UDRAFT\ING\FINAL\_P58E\0420000235ma104.dgn  
 STATE OF CALIFORNIA - DEPARTMENT OF TRANSPORTATION

REVISIONS	DATE	BY	REASON

DESIGNED BY	JAMEY VALDIVIA
CHECKED BY	ERIN MCPHERSON
FUNCTIONAL SUPERVISOR	TIMOTHY J. LEE
REVISIONS	
DATE	
BY	
REASON	

REVISIONS	DATE	BY	REASON

FOR NOTES, ABBREVIATIONS AND LEGEND, SEE SHEET SC-1 AND SC-102

APPROVED FOR STAGE CONSTRUCTION AND TRAFFIC HANDLING WORK ONLY

**STAGE CONSTRUCTION AND TRAFFIC HANDLING PLAN  
STAGE 2**

SCALE: 1" = 50'

**SC-104**

LAST REVISION DATE PLOTTED => 8-MAR-2022  
 09-29-21 TIME PLOTTED => 10:05

Dist	COUNTY	ROUTE	POST MILES TOTAL PROJECT	SHEET No.	TOTAL SHEETS
04	Ala, CC	680	R11.0/R21.9, RO.0/RO.9	618	1710
			9-29-21		
ERIN D. McPHERSON REGISTERED CIVIL ENGINEER			DATE		
October 8, 2021			PLANS APPROVAL DATE		
<small>THE STATE OF CALIFORNIA OR ITS OFFICERS OR AGENTS SHALL NOT BE RESPONSIBLE FOR THE ACCURACY OR COMPLETENESS OF SCANNED COPIES OF THIS PLAN SHEET.</small>					
WMH CORPORATION 55 South Market St Suite 1200 San Jose, CA 95113			ALAMEDA CTC 1111 Broadway Suite 800 Oakland, CA 94607		

NOTE:  
FOR ACCURATE RIGHT OF WAY DATA, CONTACT RIGHT OF WAY ENGINEERING AT THE DISTRICT OFFICE.

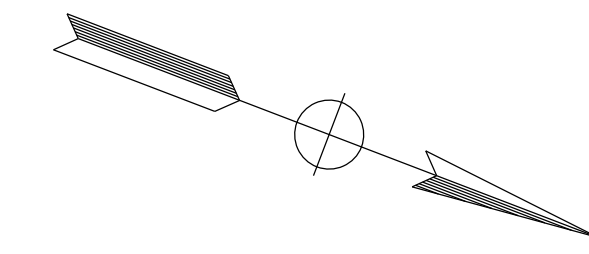

X:\680\_SB\_EXPRESS\000\_CAD\Submittal\0420000235ma105.dgn  
 STATE OF CALIFORNIA - DEPARTMENT OF TRANSPORTATION  
 CONSULTANT FUNCTIONAL SUPERVISOR: TIMOTHY J. LEE  
 CALCULATED/DESIGNED BY: JAMEY VALDIVIA  
 CHECKED BY: ERIN MCPHERSON  
 REVISED BY: JV  
 DATE REVISED: 9-29-21

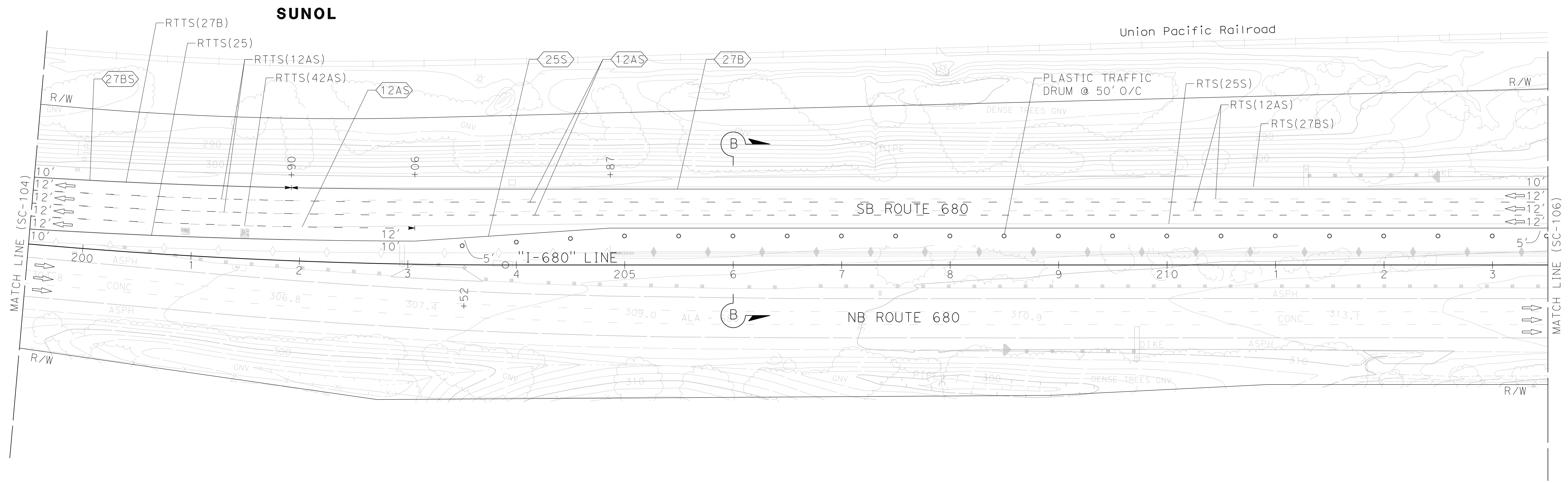

FOR NOTES, ABBREVIATIONS AND LEGEND, SEE SHEET SC-1 AND SC-102

## STAGE CONSTRUCTION AND TRAFFIC HANDLING PLAN STAGE 2

SCALE: 1" = 50'

**SC-105**

APPROVED FOR STAGE CONSTRUCTION AND TRAFFIC HANDLING WORK ONLY

LAST REVISION: DATE PLOTTED => 3/18/2022  
 09-29-21 TIME PLOTTED => 4:34:51 PM

X:\680\_SB\_EXPRESS\000\_CAD\Submittal\0420000235ma106.dgn  
 STATE OF CALIFORNIA - DEPARTMENT OF TRANSPORTATION  
 CONSULTANT FUNCTIONAL SUPERVISOR  
 JAMEY VALDIVIA  
 ERIN MCPHERSON  
 CHECKED BY  
 ERIN MCPHERSON  
 DESIGNED BY  
 JAMEY VALDIVIA  
 REVISIONS  
 REVISED BY  
 DATE REVISED  
 JV  
 9-29-21  
 SUPERVISOR  
 TIMOTHY J. LEE

NOTE:  
 FOR ACCURATE RIGHT OF WAY DATA, CONTACT RIGHT  
 OF WAY ENGINEERING AT THE DISTRICT OFFICE.

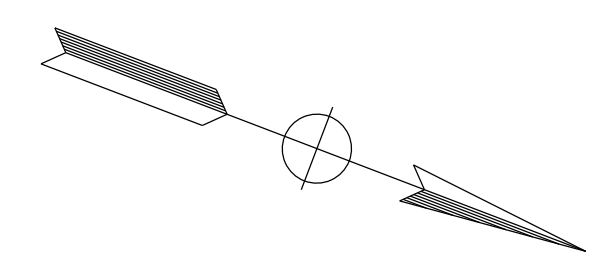

Dist	COUNTY	ROUTE	POST MILES TOTAL PROJECT	SHEET No.	TOTAL SHEETS
04	Ala, CC	680	R11.0/R21.9, R0.0/R0.9	619	1710
			9-29-21		
REGISTERED CIVIL ENGINEER			DATE		
			October 8, 2021		
			PLANS APPROVAL DATE		
<small>THE STATE OF CALIFORNIA OR ITS OFFICERS OR AGENTS SHALL NOT BE RESPONSIBLE FOR THE ACCURACY OR COMPLETENESS OF SCANNED COPIES OF THIS PLAN SHEET.</small>					
WMH CORPORATION 55 South Market St Suite 1200 San Jose, CA 95113			ALAMEDA CTC 1111 Broadway Suite 800 Oakland, CA 94607		

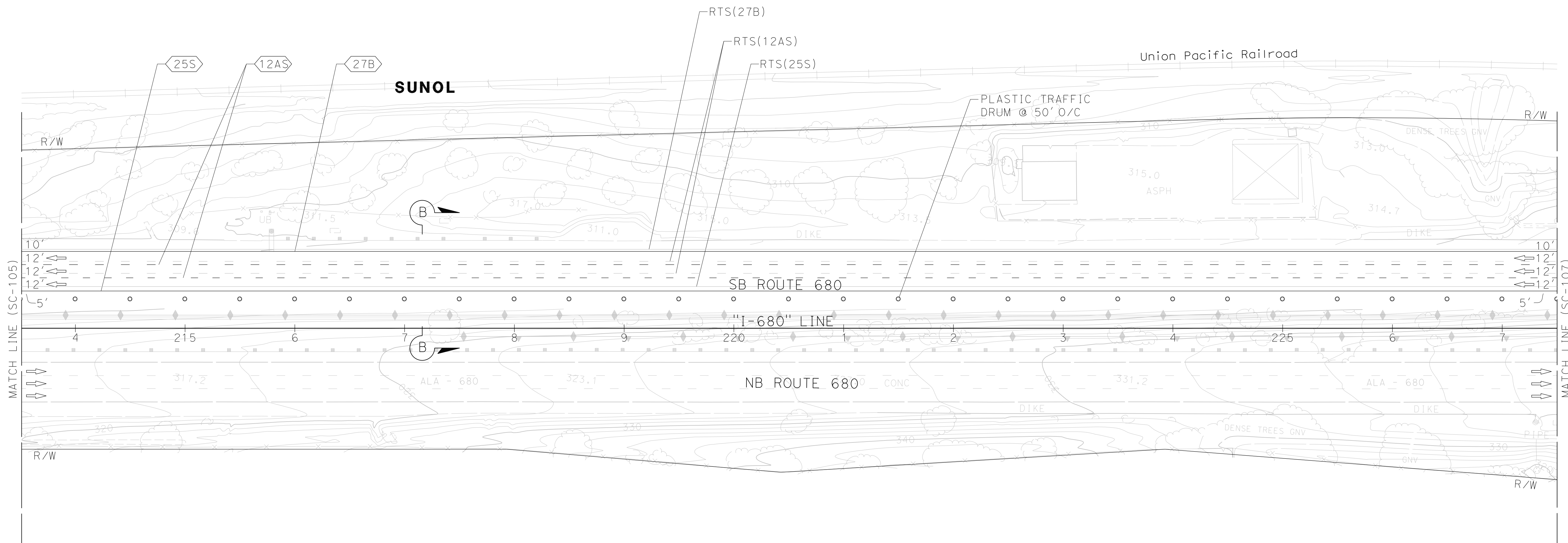

FOR NOTES, ABBREVIATIONS AND  
 LEGEND, SEE SHEET SC-1 AND SC-102

APPROVED FOR STAGE CONSTRUCTION AND TRAFFIC HANDLING WORK ONLY

## STAGE CONSTRUCTION AND TRAFFIC HANDLING PLAN STAGE 2

SCALE: 1" = 50'

**SC-106**

LAST REVISION    DATE PLOTTED => 3/18/2022  
 09-29-21    TIME PLOTTED => 4:55:01 PM

O:\00300\DRAWING\FINAL\_P5&E\0420000235ma107.dgn  
 STATE OF CALIFORNIA - DEPARTMENT OF TRANSPORTATION  
**Caltrans**  
 CONSULTANT - FUNCTIONAL SUPERVISOR: TIMOTHY J. LEE  
 CALCULATED/DESIGNED BY: JAMEY VALDIVIA  
 CHECKED BY: ERIN MCPHERSON  
 REVISED BY: JV  
 DATE REVISED: 9-29-21

NOTE:  
 FOR ACCURATE RIGHT OF WAY DATA, CONTACT RIGHT OF WAY ENGINEERING AT THE DISTRICT OFFICE.

Dist	COUNTY	ROUTE	POST MILES TOTAL PROJECT	SHEET No.	TOTAL SHEETS
04	Ala, CC	680	R11.0/R21.9, RO.0/RO.9	620	1710

REGISTERED CIVIL ENGINEER: *Erin D. McPherson*  
 DATE: 9-29-21  
 PLANS APPROVAL DATE: October 8, 2021



THE STATE OF CALIFORNIA OR ITS OFFICERS OR AGENTS SHALL NOT BE RESPONSIBLE FOR THE ACCURACY OR COMPLETENESS OF SCANNED COPIES OF THIS PLAN SHEET.

WMH CORPORATION 55 South Market St Suite 1200 San Jose, CA 95113	ALAMEDA CTC 1111 Broadway Suite 800 Oakland, CA 94607
---------------------------------------------------------------------------	----------------------------------------------------------------

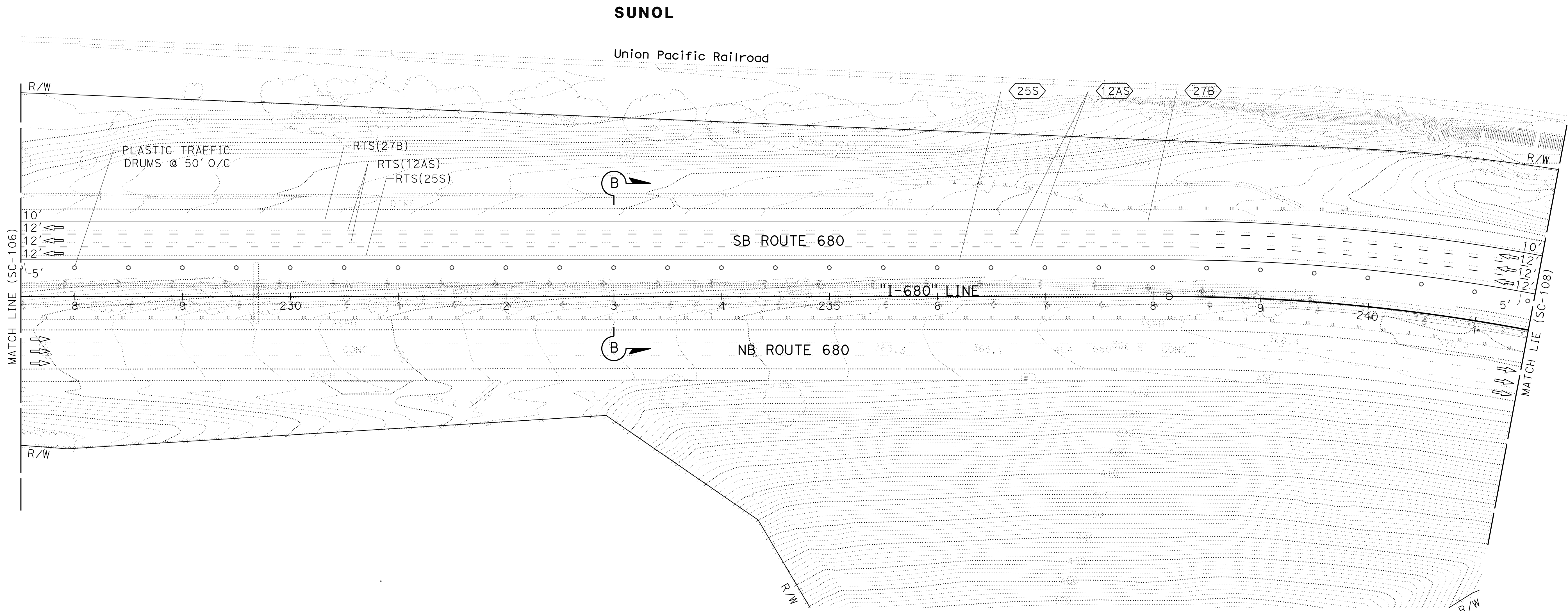
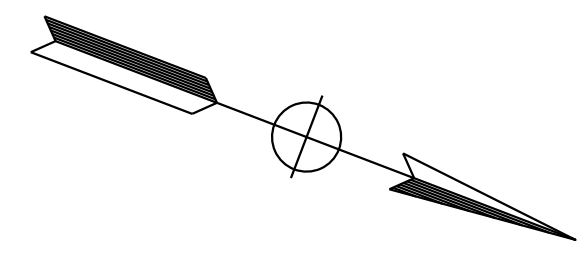

FOR NOTES, ABBREVIATIONS AND LEGEND, SEE SHEET SC-1 AND SC-102

APPROVED FOR STAGE CONSTRUCTION AND TRAFFIC HANDLING WORK ONLY

**STAGE CONSTRUCTION  
AND TRAFFIC HANDLING PLAN  
STAGE 2**

SCALE: 1" = 50'

**SC-107**

LAST REVISION: DATE PLOTTED => 8-MAR-2022    TIME PLOTTED => 10:05

**NOTE:**  
FOR ACCURATE RIGHT OF WAY DATA, CONTACT RIGHT OF WAY ENGINEERING AT THE DISTRICT OFFICE.

Dist	COUNTY	ROUTE	POST MILES TOTAL PROJECT	SHEET No.	TOTAL SHEETS
04	Ala, CC	680	R11.0/R21.9, R0.0/R0.9	621	1710

<i>Erin D. McPherson</i> REGISTERED CIVIL ENGINEER	9-29-21 DATE
October 8, 2021 PLANS APPROVAL DATE	

ERIN D. McPHERSON No. C91111 Exp. 3-31-24 CIVIL STATE OF CALIFORNIA	THE STATE OF CALIFORNIA OR ITS OFFICERS OR AGENTS SHALL NOT BE RESPONSIBLE FOR THE ACCURACY OR COMPLETENESS OF SCANNED COPIES OF THIS PLAN SHEET.
WMH CORPORATION 55 South Market St Suite 1200 San Jose, CA 95113	ALAMEDA CTC 1111 Broadway Suite 800 Oakland, CA 94607



**SUNOL**

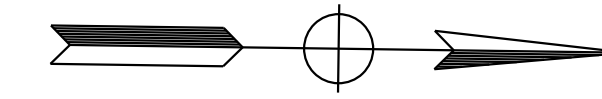

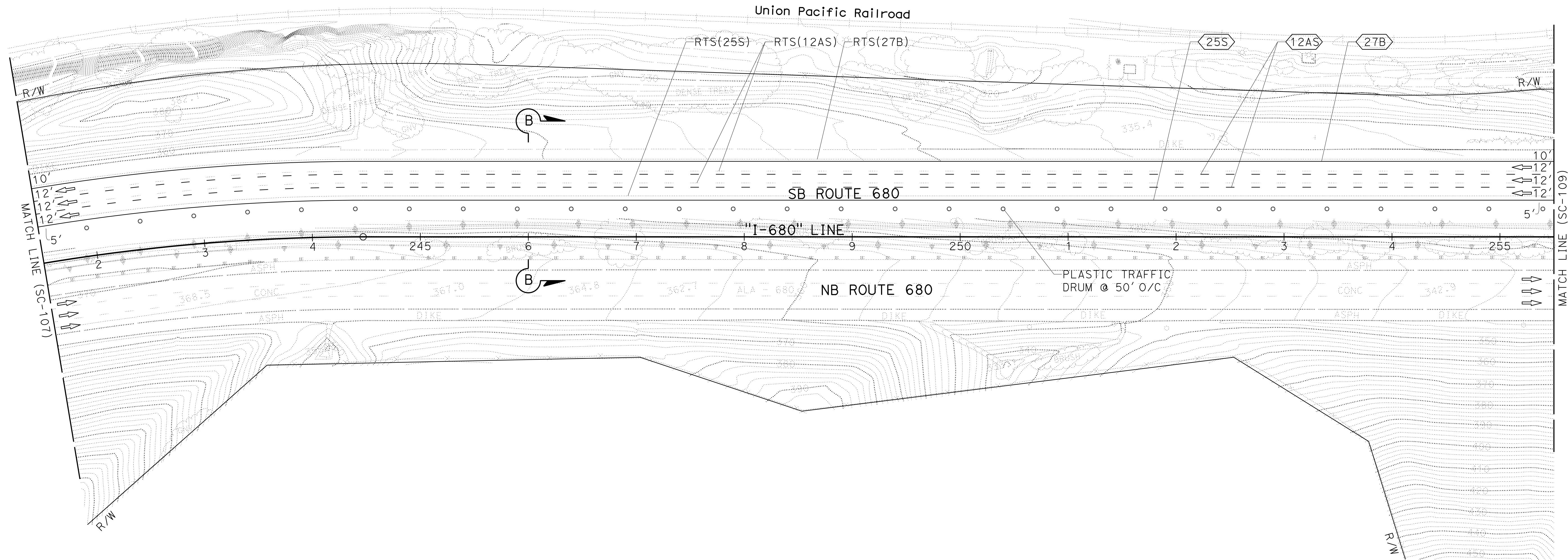
**STAGE CONSTRUCTION  
AND TRAFFIC HANDLING PLAN  
STAGE 2**

SCALE: 1" = 50'

**SC-108**

FOR NOTES, ABBREVIATIONS AND LEGEND, SEE SHEET SC-1 AND SC-102

APPROVED FOR STAGE CONSTRUCTION AND TRAFFIC HANDLING WORK ONLY

STATE OF CALIFORNIA - DEPARTMENT OF TRANSPORTATION <b>Caltrans</b>	CONSULTANT - FUNCTIONAL SUPERVISOR	TIMOTHY J. LEE
	CALCULATED - DESIGNED BY	JAMEY VALDIVIA
	CHECKED BY	ERIN McPHERSON
	REVISOR	JV
DATE	9-29-21	

Dist	COUNTY	ROUTE	POST MILES TOTAL PROJECT	SHEET No.	TOTAL SHEETS
04	Ala, CC	680	R11.0/R21.9, R0.0/R0.9	622	1710
			9-29-21		
REGISTERED CIVIL ENGINEER			DATE		
October 8, 2021			PLANS APPROVAL DATE		
WMH CORPORATION 55 South Market St Suite 1200 San Jose, CA 95113			ALAMEDA CTC 1111 Broadway Suite 800 Oakland, CA 94607		

NOTE:  
FOR ACCURATE RIGHT OF WAY DATA, CONTACT RIGHT  
OF WAY ENGINEERING AT THE DISTRICT OFFICE.

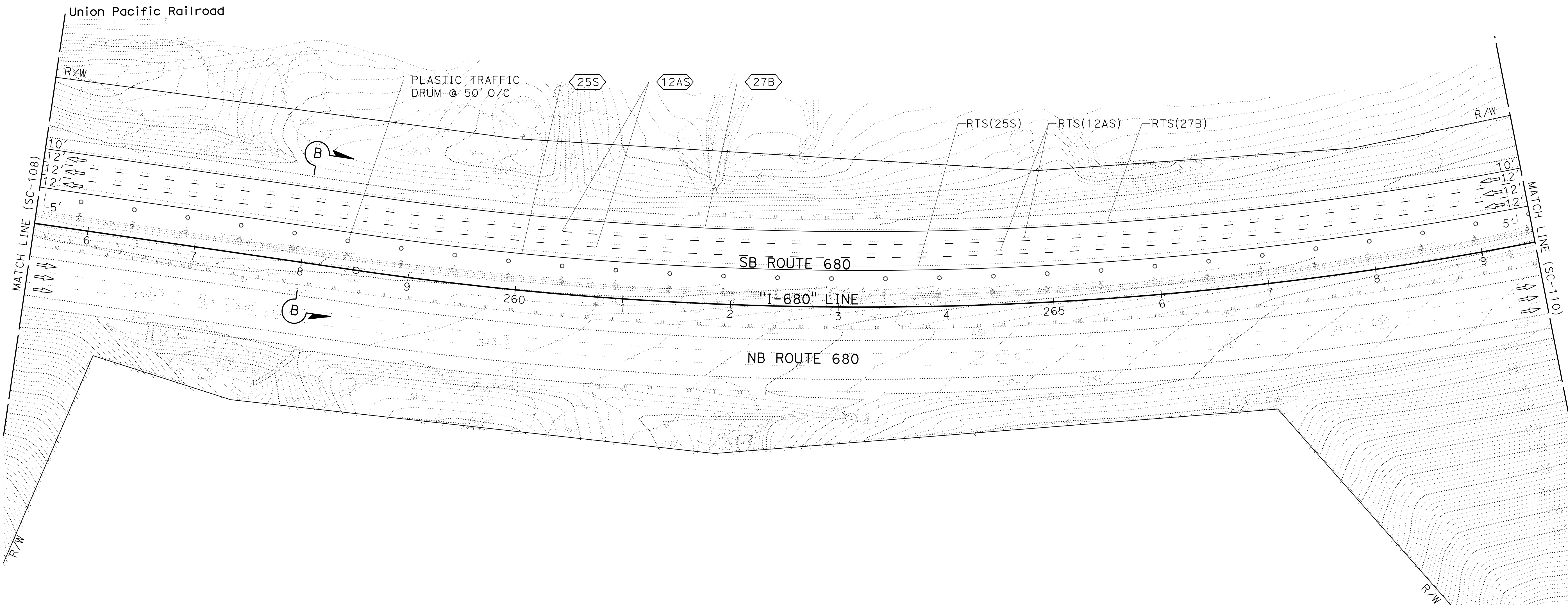
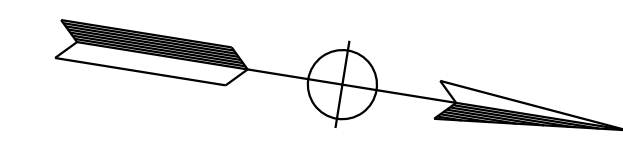

## STAGE CONSTRUCTION AND TRAFFIC HANDLING PLAN STAGE 2

SCALE: 1" = 50'

**SC-109**

FOR NOTES, ABBREVIATIONS AND  
LEGEND, SEE SHEET SC-1 AND SC-102

APPROVED FOR STAGE CONSTRUCTION AND TRAFFIC HANDLING WORK ONLY

DESIGNED BY	JAMEY VALDIVIA
CHECKED BY	ERIN MCPHERSON
FUNCTIONAL SUPERVISOR	TIMOTHY J. LEE
DESIGNED BY	JV
DATE REVISION	9-29-21

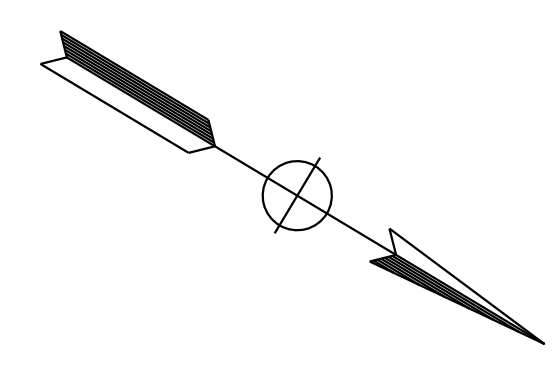

Dist	COUNTY	ROUTE	POST MILES TOTAL PROJECT	SHEET No.	TOTAL SHEETS
04	Ala, CC	680	R11.0/R21.9, RO.0/RO.9	623	1710
			9-29-21		
REGISTERED CIVIL ENGINEER <i>Erin D. McPherson</i>			DATE		
			October 8, 2021		
			PLANS APPROVAL DATE		
THE STATE OF CALIFORNIA OR ITS OFFICERS OR AGENTS SHALL NOT BE RESPONSIBLE FOR THE ACCURACY OR COMPLETENESS OF SCANNED COPIES OF THIS PLAN SHEET.					
WMH CORPORATION 55 South Market St Suite 1200 San Jose, CA 95113			ALAMEDA CTC 1111 Broadway Suite 800 Oakland, CA 94607		



NOTE:  
FOR ACCURATE RIGHT OF WAY DATA, CONTACT RIGHT OF WAY ENGINEERING AT THE DISTRICT OFFICE.

DESIGNED BY	JAMEY VALDIVIA
CHECKED BY	ERIN MCPHERSON
CALCULATED/DESIGNED BY	
CONSULTANT SUPERVISOR	TIMOTHY J. LEE
FUNCTIONAL SUPERVISOR	
REVISOR	JV
DATE	9-29-21
REVISED BY	
DATE	

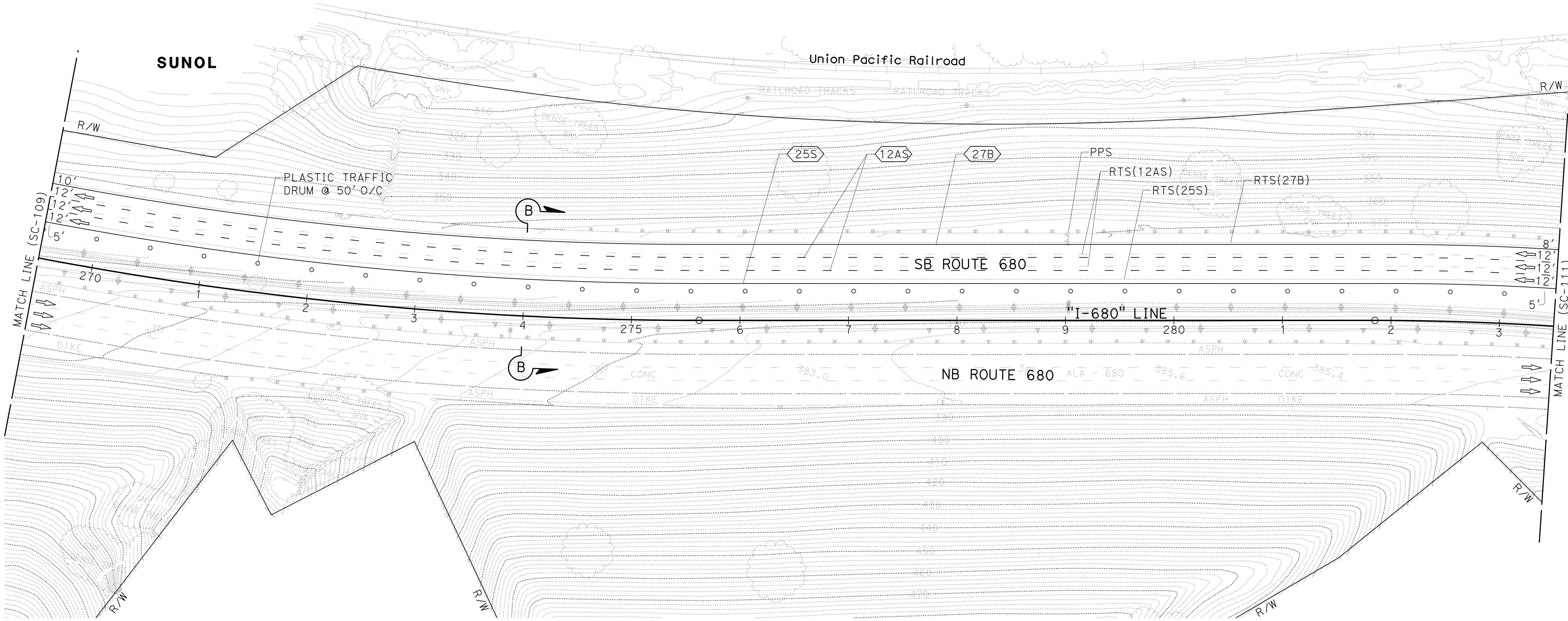

FOR NOTES, ABBREVIATIONS AND LEGEND, SEE SHEET SC-1 AND SC-102

APPROVED FOR STAGE CONSTRUCTION AND TRAFFIC HANDLING WORK ONLY

**STAGE CONSTRUCTION AND TRAFFIC HANDLING PLAN**  
**STAGE 2**

SCALE: 1" = 50'

**SC-110**

O:\00300\DRAWING\FINAL\_P5&E\0420000235ma110.dgn



LAST REVISION: 09-29-21      DATE PLOTTED => 8-MAR-2022      TIME PLOTTED => 10:06

Dist	COUNTY	ROUTE	POST MILES TOTAL PROJECT	SHEET No.	TOTAL SHEETS
04	Ala, CC	680	R11.0/R21.9, RO.0/RO.9	624	1710
			9-29-21		
REGISTERED CIVIL ENGINEER			DATE		
October 8, 2021			PLANS APPROVAL DATE		
WMH CORPORATION 55 South Market St Suite 1200 San Jose, CA 95113			ALAMEDA CTC 1111 Broadway Suite 800 Oakland, CA 94607		

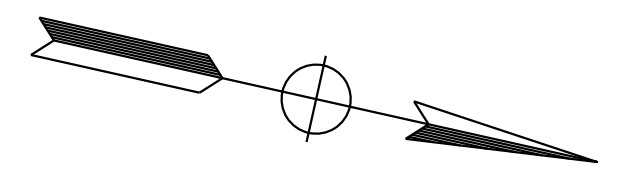

**NOTE:**  
FOR ACCURATE RIGHT OF WAY DATA, CONTACT RIGHT OF WAY ENGINEERING AT THE DISTRICT OFFICE.

STATE OF CALIFORNIA - DEPARTMENT OF TRANSPORTATION	CONSULTANT	FUNCTIONAL SUPERVISOR	CALCULATED-DESIGNED BY	REVISOR	DATE
	JAMEY VALDIVIA	TIMOTHY J. LEE	ERIN MCPHERSON	JV	9-29-21
	ERIN MCPHERSON				

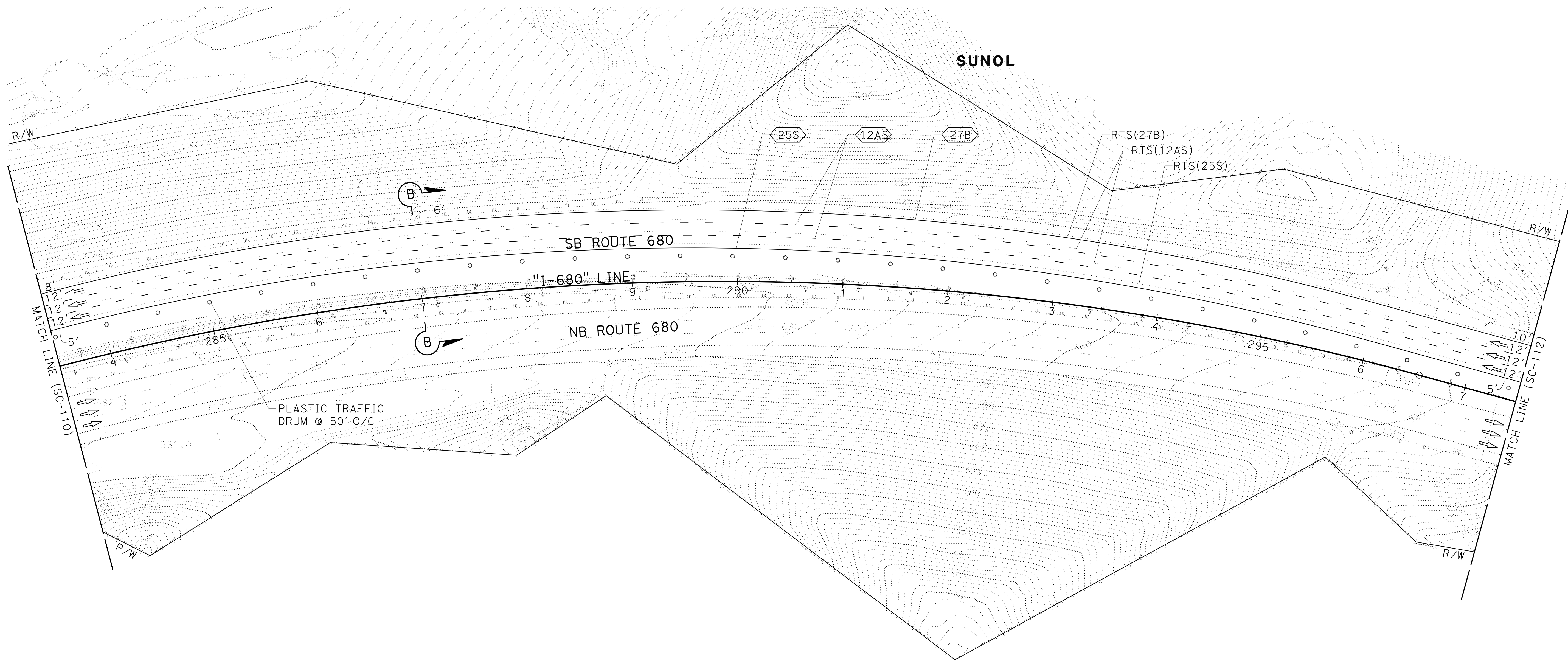

FOR NOTES, ABBREVIATIONS AND LEGEND, SEE SHEET SC-1 AND SC-102

**STAGE CONSTRUCTION AND TRAFFIC HANDLING PLAN**  
**STAGE 2**

SCALE: 1" = 50'

**SC-111**

APPROVED FOR STAGE CONSTRUCTION AND TRAFFIC HANDLING WORK ONLY

Dist	COUNTY	ROUTE	POST MILES TOTAL PROJECT	SHEET No.	TOTAL SHEETS
04	Ala, CC	680	R11.0/R21.9, RO.0/RO.9	625	1710

REGISTERED CIVIL ENGINEER  
 ERIN D. McPHERSON  
 No. C91111  
 Exp. 3-31-24  
 CIVIL  
 STATE OF CALIFORNIA

9-29-21  
 DATE  
 October 8, 2021  
 PLANS APPROVAL DATE

THE STATE OF CALIFORNIA OR ITS OFFICERS OR AGENTS SHALL NOT BE RESPONSIBLE FOR THE ACCURACY OR COMPLETENESS OF SCANNED COPIES OF THIS PLAN SHEET.

WMH CORPORATION  
 55 South Market St  
 Suite 1200  
 San Jose, CA 95113

ALAMEDA CTC  
 1111 Broadway  
 Suite 800  
 Oakland, CA 94607

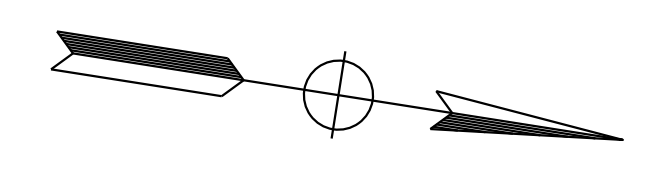

**NOTE:**  
 FOR ACCURATE RIGHT OF WAY DATA, CONTACT RIGHT OF WAY ENGINEERING AT THE DISTRICT OFFICE.

REVISED BY	DATE REVISED	CHECKED BY	DESIGNED BY	FUNCTIONAL SUPERVISOR	CONSULTANT	DEPARTMENT OF TRANSPORTATION	STATE OF CALIFORNIA
JV	9-29-21	ERIN McPHERSON	JAMEY VALDIVIA	TIMOTHY J. LEE			

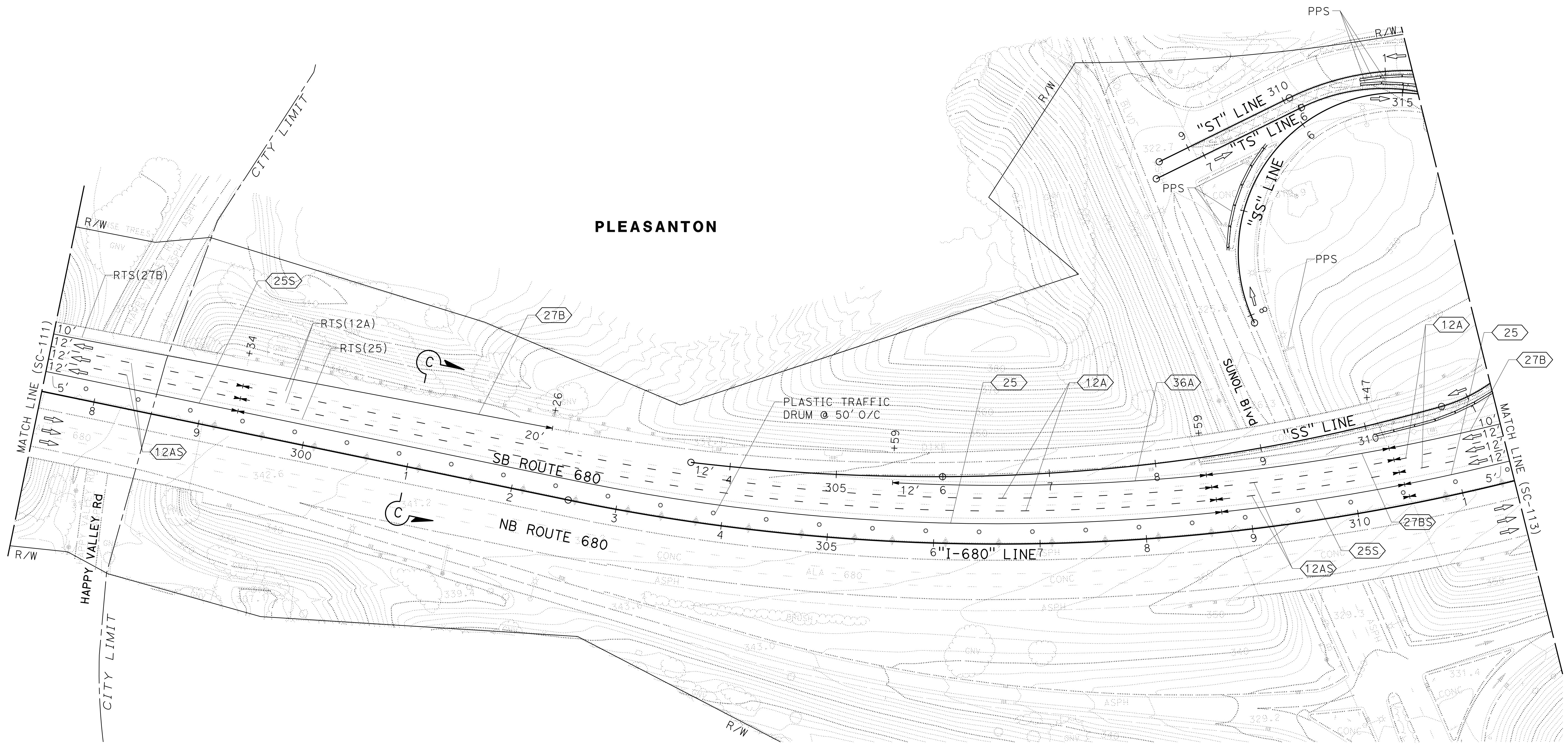

FOR NOTES, ABBREVIATIONS AND LEGEND, SEE SHEET SC-1 AND SC-102



APPROVED FOR STAGE CONSTRUCTION AND TRAFFIC HANDLING WORK ONLY

## STAGE CONSTRUCTION AND TRAFFIC HANDLING PLAN STAGE 2

SCALE: 1" = 50'

**SC-112**

LAST REVISION DATE PLOTTED => 8-MAR-2022  
 09-29-21 TIME PLOTTED => 10:06

Dist	COUNTY	ROUTE	POST MILES TOTAL PROJECT	SHEET No.	TOTAL SHEETS
04	Ala, CC	680	R11.0/R21.9, R0.0/R0.9	626	1710
			9-29-21		
 REGISTERED CIVIL ENGINEER			DATE		
			October 8, 2021		
			PLANS APPROVAL DATE		
<small>THE STATE OF CALIFORNIA OR ITS OFFICERS OR AGENTS SHALL NOT BE RESPONSIBLE FOR THE ACCURACY OR COMPLETENESS OF SCANNED COPIES OF THIS PLAN SHEET.</small>					
WMH CORPORATION 55 South Market St Suite 1200 San Jose, CA 95113			ALAMEDA CTC 1111 Broadway Suite 800 Oakland, CA 94607		

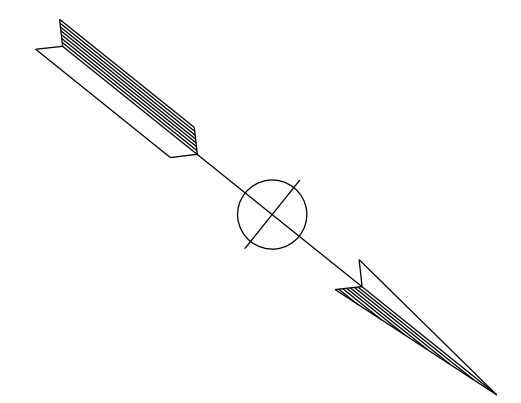

NOTE:  
FOR ACCURATE RIGHT OF WAY DATA, CONTACT RIGHT OF WAY ENGINEERING AT THE DISTRICT OFFICE.

STATE OF CALIFORNIA - DEPARTMENT OF TRANSPORTATION	CONSULTANT FUNCTIONAL SUPERVISOR	REVISOR	DATE
Ernst & Young	TIMOTHY J. LEE	JV	9-29-21
	CHECKED BY	REVISOR	DATE
	ERIN MCPHERSON	JV	9-29-21
	DESIGNED BY		
	JAMEY VALDIVIA		

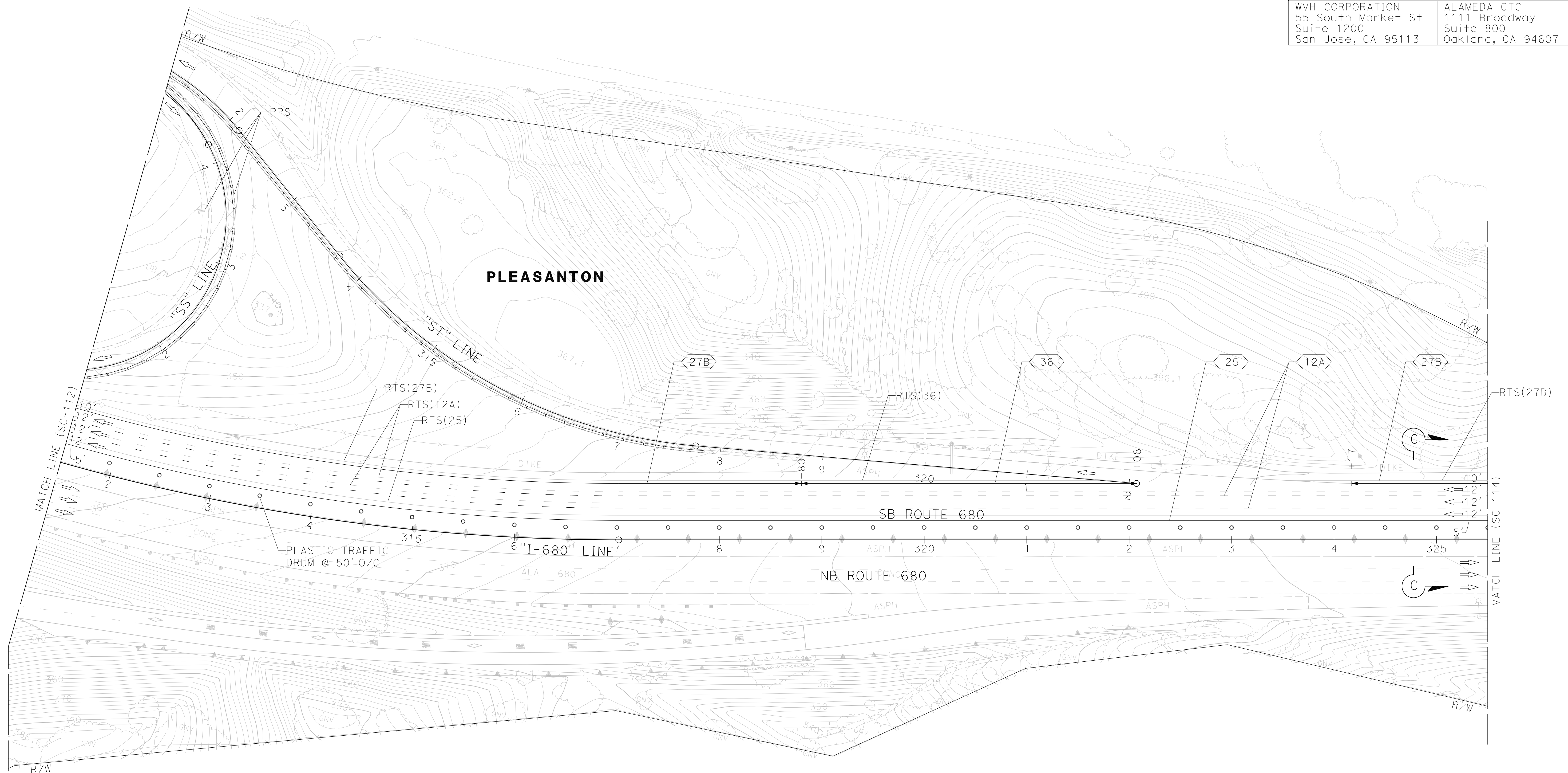

FOR NOTES, ABBREVIATIONS AND LEGEND, SEE SHEET SC-1 AND SC-102

## STAGE CONSTRUCTION AND TRAFFIC HANDLING PLAN STAGE 2

SCALE: 1" = 50'

**SC-113**

APPROVED FOR STAGE CONSTRUCTION AND TRAFFIC HANDLING WORK ONLY

LAST REVISION      DATE PLOTTED => 3/18/2022      09-29-21      TIME PLOTTED => 4:35:32 PM

NOTE:  
FOR ACCURATE RIGHT OF WAY DATA, CONTACT RIGHT  
OF WAY ENGINEERING AT THE DISTRICT OFFICE.

Dist	COUNTY	ROUTE	POST MILES TOTAL PROJECT	SHEET No.	TOTAL SHEETS
04	Ala, CC	680	R11.0/R21.9, R0.0/R0.9	627	1710

*Erin D. McPherson* 9-29-21  
 REGISTERED CIVIL ENGINEER DATE

October 8, 2021  
 PLANS APPROVAL DATE

THE STATE OF CALIFORNIA OR ITS OFFICERS  
 OR AGENTS SHALL NOT BE RESPONSIBLE FOR  
 THE ACCURACY OR COMPLETENESS OF SCANNED  
 COPIES OF THIS PLAN SHEET.

WMH CORPORATION 55 South Market St Suite 1200 San Jose, CA 95113	ALAMEDA CTC 1111 Broadway Suite 800 Oakland, CA 94607
---------------------------------------------------------------------------	----------------------------------------------------------------

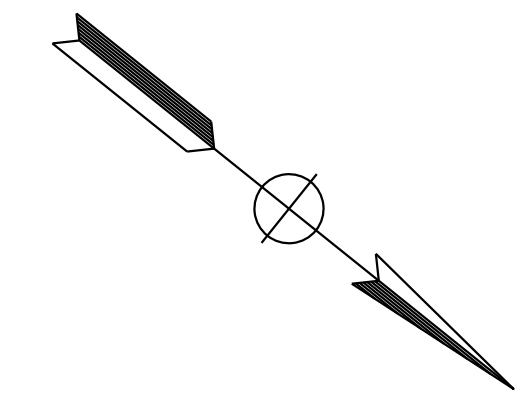

STATE OF CALIFORNIA - DEPARTMENT OF TRANSPORTATION  
 Er<sup>®</sup> Caltrans<sup>®</sup>  
 USERNAME => p302438  
 DGN FILE => 0420000235ma114.dgn  
 BORDER LAST REVISED 7/2/2010

DESIGNED BY	JAMIEY VALDIVIA
CHECKED BY	ERIN MCPHERSON
REVISOR	JV
DATE	9-29-21

FUNCTIONAL SUPERVISOR	TIMOTHY J. LEE
CONSULTANT	

DESIGNED BY	JAMIEY VALDIVIA
CHECKED BY	ERIN MCPHERSON
REVISOR	JV
DATE	9-29-21

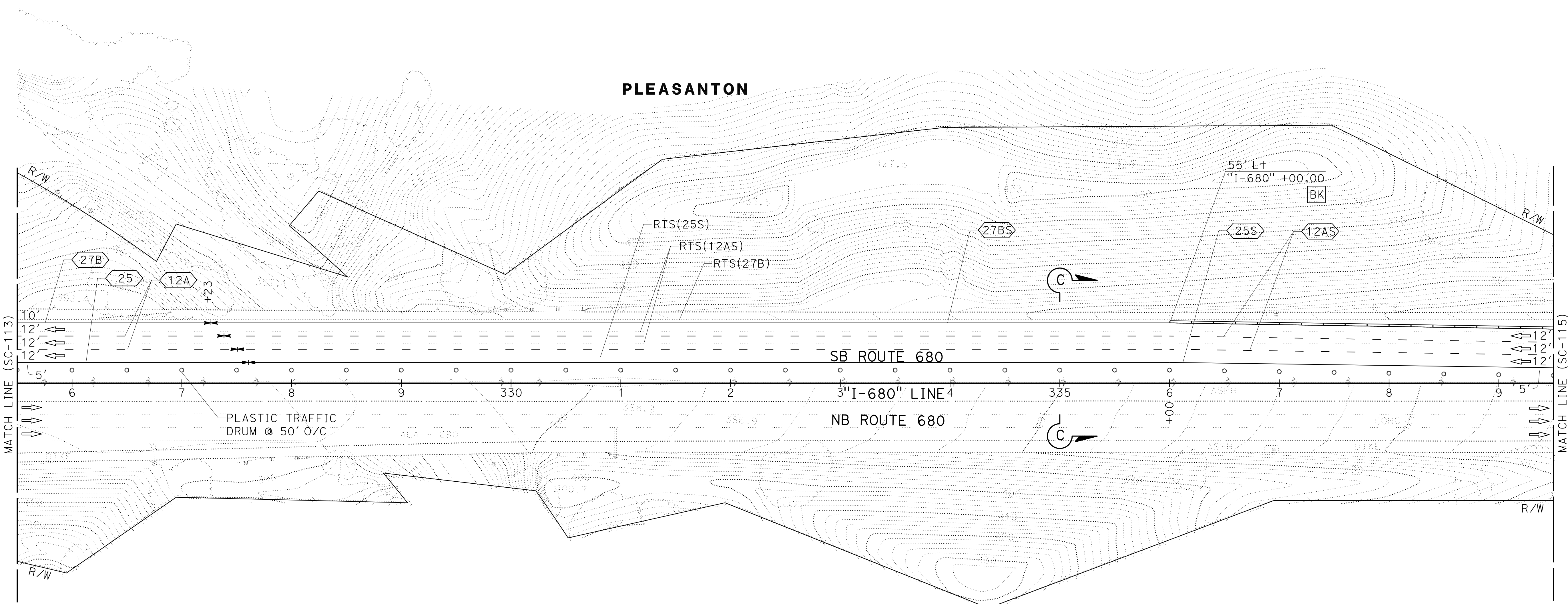

FOR NOTES, ABBREVIATIONS AND  
LEGEND, SEE SHEET SC-1 AND SC-102

APPROVED FOR STAGE CONSTRUCTION AND TRAFFIC HANDLING WORK ONLY

**STAGE CONSTRUCTION  
AND TRAFFIC HANDLING PLAN  
STAGE 2**

SCALE: 1" = 50'

**SC-114**

LAST REVISION: 09-29-21 10:06  
 DATE PLOTTED => 8-MAR-2022  
 TIME PLOTTED => 10:06

Dist	COUNTY	ROUTE	POST MILES TOTAL PROJECT	SHEET No.	TOTAL SHEETS
04	Ala, CC	680	R11.0/R21.9, RO.0/RO.9	628	1710
			9-29-21		
REGISTERED CIVIL ENGINEER			DATE		
October 8, 2021			PLANS APPROVAL DATE		
WMH CORPORATION 55 South Market St Suite 1200 San Jose, CA 95113			ALAMEDA CTC 1111 Broadway Suite 800 Oakland, CA 94607		

NOTE:  
FOR ACCURATE RIGHT OF WAY DATA, CONTACT RIGHT OF WAY ENGINEERING AT THE DISTRICT OFFICE.

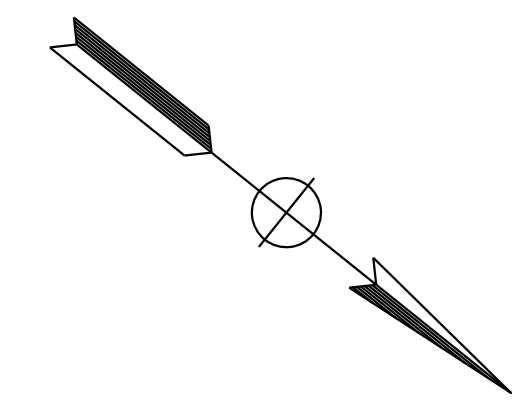

DESIGNED BY	JV	DATE	9-29-21
REVISOR		DATE	
CHECKED BY	ERIN MCPHERSON		
DESIGNED BY	JAMEY VALDIVIA		
DESIGNED BY	ERIN MCPHERSON		
DESIGNED BY	TIMOTHY J. LEE		

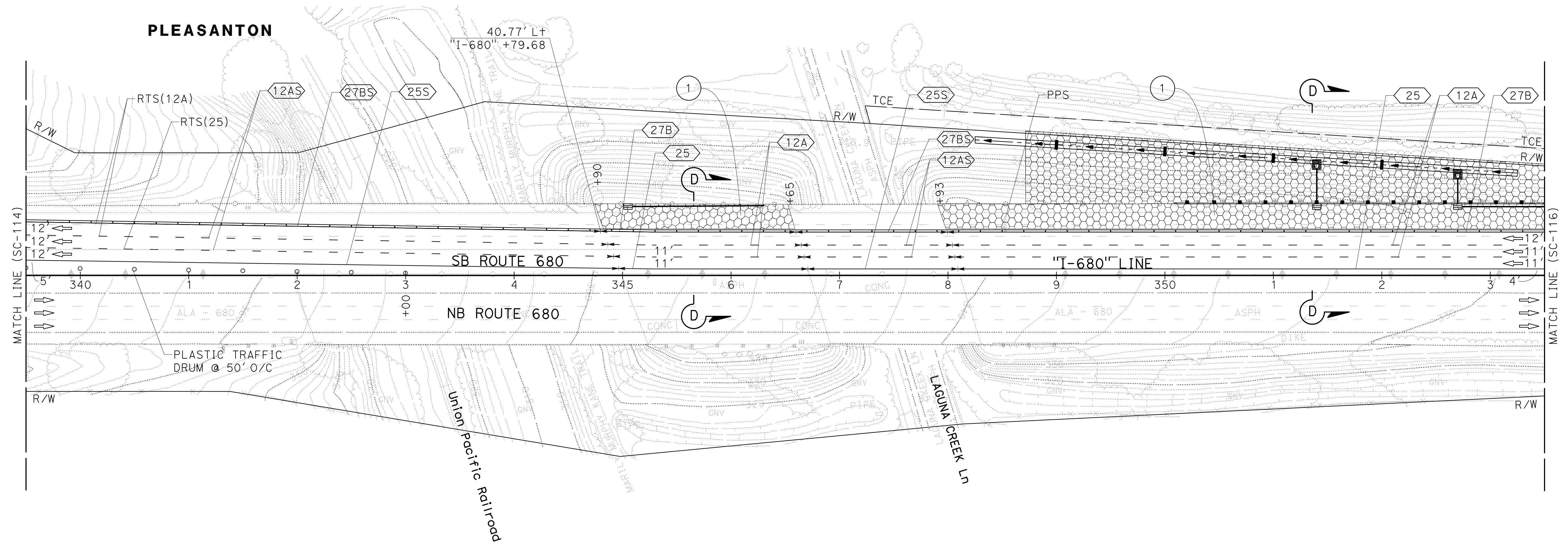

FOR NOTES, ABBREVIATIONS AND LEGEND, SEE SHEET SC-1 AND SC-102

APPROVED FOR STAGE CONSTRUCTION AND TRAFFIC HANDLING WORK ONLY

## STAGE CONSTRUCTION AND TRAFFIC HANDLING PLAN STAGE 2

SCALE: 1" = 50'

**SC-115**

Dist	COUNTY	ROUTE	POST MILES TOTAL PROJECT	SHEET No.	TOTAL SHEETS
04	Ala, CC	680	R11.0/R21.9, RO.0/RO.9	629	1710
			REGISTERED CIVIL ENGINEER	DATE	
			ERIN D. McPHERSON	9-29-21	
			PLANS APPROVAL DATE		
			October 8, 2021		
<small>THE STATE OF CALIFORNIA OR ITS OFFICERS OR AGENTS SHALL NOT BE RESPONSIBLE FOR THE ACCURACY OR COMPLETENESS OF SCANNED COPIES OF THIS PLAN SHEET.</small>					
WMH CORPORATION 55 South Market St Suite 1200 San Jose, CA 95113			ALAMEDA CTC 1111 Broadway Suite 800 Oakland, CA 94607		



NOTE:  
FOR ACCURATE RIGHT OF WAY DATA, CONTACT RIGHT OF WAY ENGINEERING AT THE DISTRICT OFFICE.

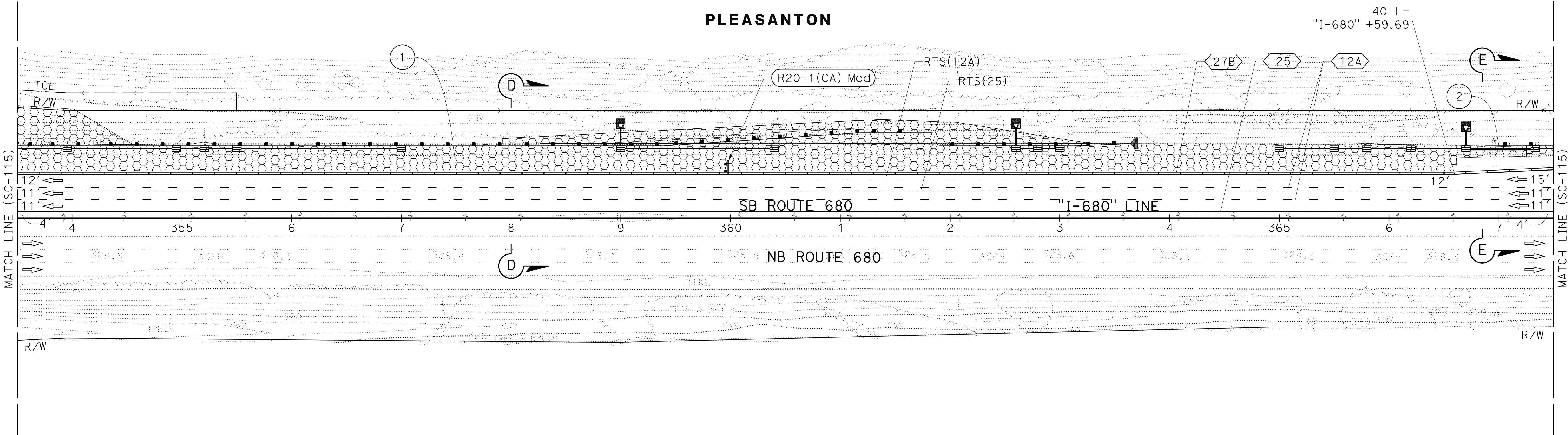
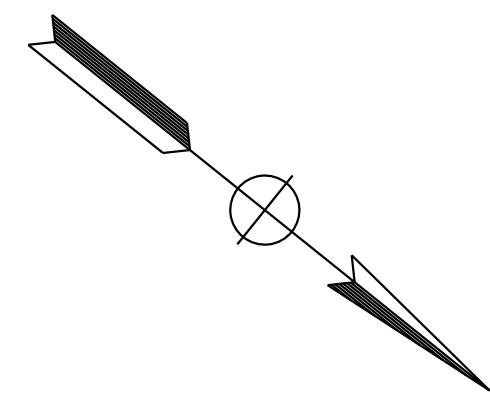

## STAGE CONSTRUCTION AND TRAFFIC HANDLING PLAN STAGE 2

SCALE: 1" = 50'

**SC-116**

APPROVED FOR STAGE CONSTRUCTION AND TRAFFIC HANDLING WORK ONLY

FOR NOTES, ABBREVIATIONS AND LEGEND, SEE SHEET SC-1 AND SC-102

STATE OF CALIFORNIA - DEPARTMENT OF TRANSPORTATION	CONSULTANT	FUNCTIONAL SUPERVISOR	CALCULATED-DESIGNED BY	REVISOR	DATE
Ervin	TIMOTHY J. LEE	JAMEY VALDIVIA	ERIN McPHERSON	JV	9-29-21

Dist	COUNTY	ROUTE	POST MILES TOTAL PROJECT	SHEET No.	TOTAL SHEETS
04	Ala, CC	680	R11.0/R21.9, RO.0/RO.9	630	1710
			REGISTERED CIVIL ENGINEER	DATE	
			ERIN D. McPHERSON	9-29-21	
			PLANS APPROVAL DATE		
			October 8, 2021		
<small>THE STATE OF CALIFORNIA OR ITS OFFICERS OR AGENTS SHALL NOT BE RESPONSIBLE FOR THE ACCURACY OR COMPLETENESS OF SCANNED COPIES OF THIS PLAN SHEET.</small>					
WMH CORPORATION			ALAMEDA CTC		
55 South Market St			1111 Broadway		
San Jose, CA 95113			Suite 800		
			Oakland, CA 94607		



NOTE:  
FOR ACCURATE RIGHT OF WAY DATA, CONTACT RIGHT OF WAY ENGINEERING AT THE DISTRICT OFFICE.

DESIGNED BY	JV
DATE	9-29-21
REVISOR	
DATE	
CALCULATED/DESIGNED BY	JAMEY VALDIVIA
CHECKED BY	ERIN McPHERSON
CONSULTANT SUPERVISOR	TIMOTHY J. LEE
FUNCTIONAL SUPERVISOR	
DEPARTMENT OF TRANSPORTATION	

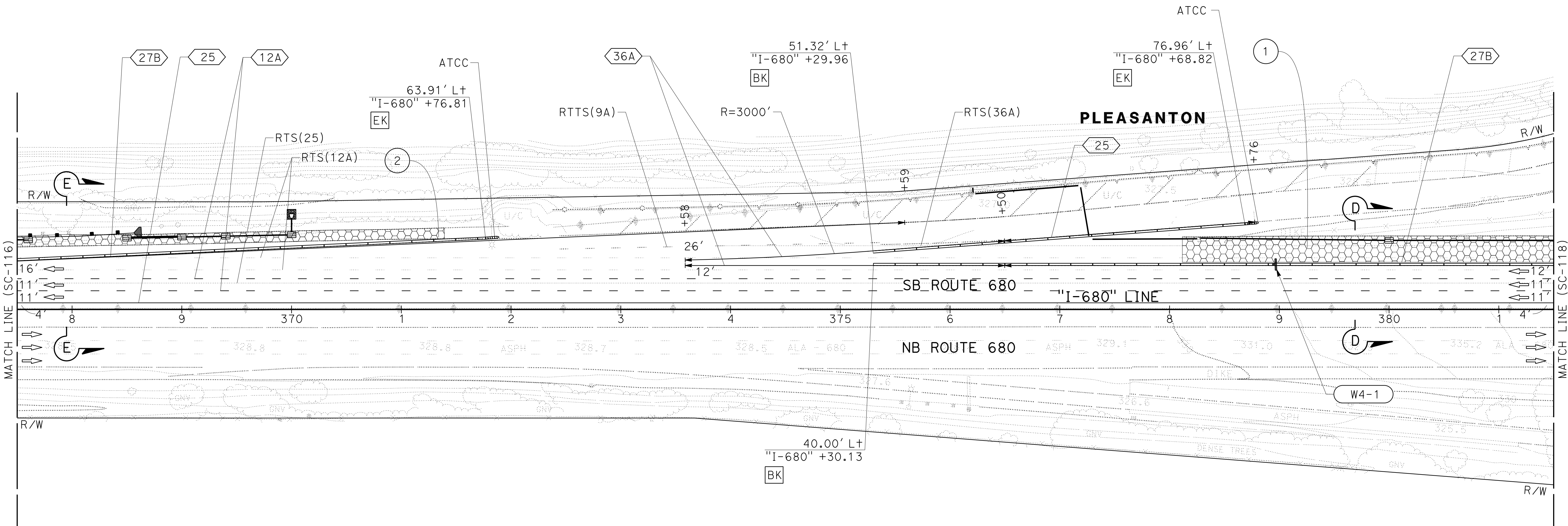

## STAGE CONSTRUCTION AND TRAFFIC HANDLING PLAN STAGE 2

SCALE: 1" = 50'

**SC-117**

FOR NOTES, ABBREVIATIONS AND LEGEND, SEE SHEET SC-1 AND SC-102

APPROVED FOR STAGE CONSTRUCTION AND TRAFFIC HANDLING WORK ONLY

O:\00300\DRAWING\FINAL\_P&E\0420000235ma117.dgn



LAST REVISION DATE PLOTTED => 8-MAR-2022 09-29-21 TIME PLOTTED => 10:06

Dist	COUNTY	ROUTE	POST MILES TOTAL PROJECT	SHEET No.	TOTAL SHEETS
04	Ala, CC	680	R11.0/R21.9, RO.0/RO.9	631	1710
			9-29-21		
REGISTERED CIVIL ENGINEER			DATE		
			October 8, 2021		
			PLANS APPROVAL DATE		
<small>THE STATE OF CALIFORNIA OR ITS OFFICERS OR AGENTS SHALL NOT BE RESPONSIBLE FOR THE ACCURACY OR COMPLETENESS OF SCANNED COPIES OF THIS PLAN SHEET.</small>					
WMH CORPORATION 55 South Market St Suite 1200 San Jose, CA 95113			ALAMEDA CTC 1111 Broadway Suite 800 Oakland, CA 94607		



NOTE:  
FOR ACCURATE RIGHT OF WAY DATA, CONTACT RIGHT OF WAY ENGINEERING AT THE DISTRICT OFFICE.

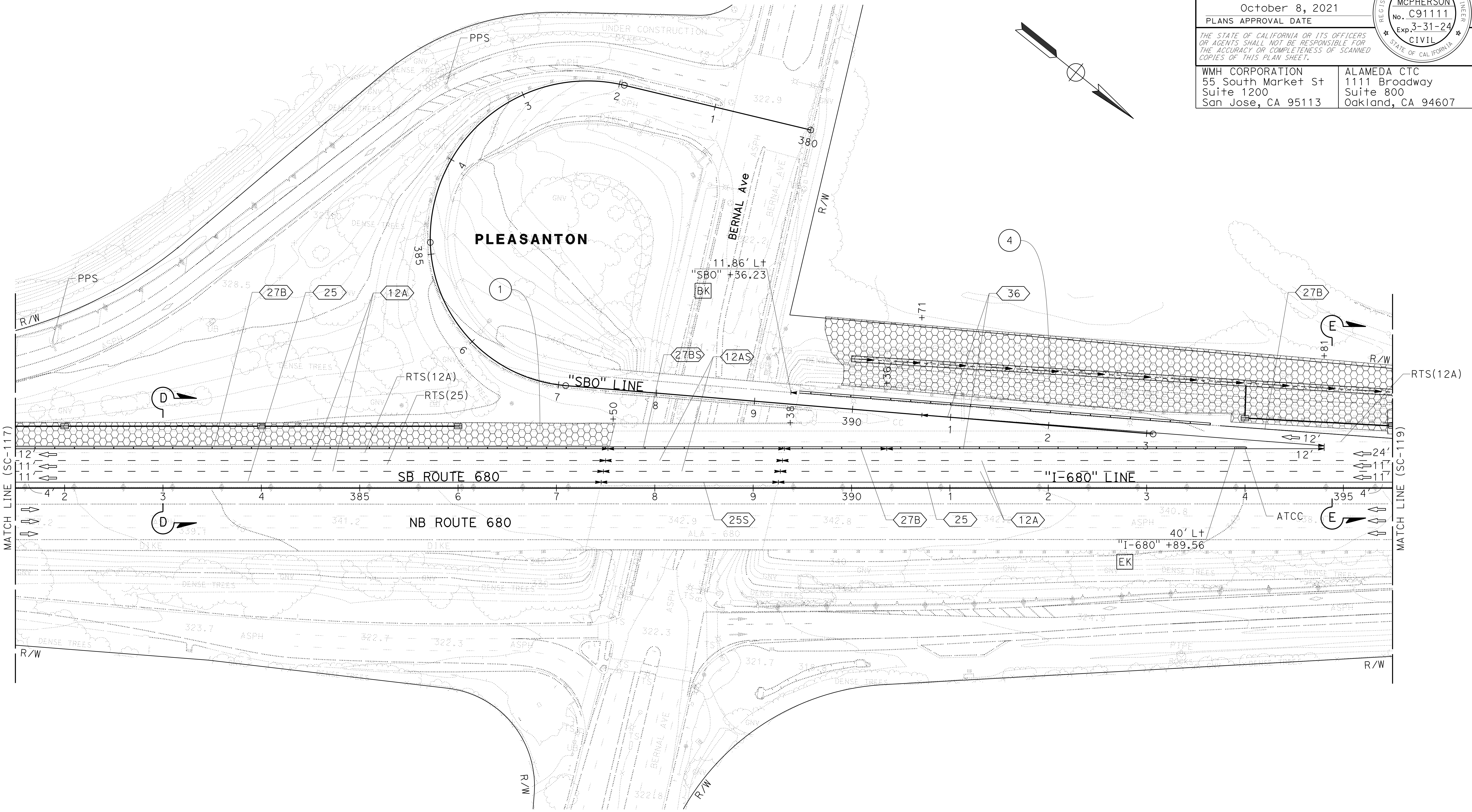

## STAGE CONSTRUCTION AND TRAFFIC HANDLING PLAN STAGE 2

SCALE: 1" = 50'

**SC-118**

APPROVED FOR STAGE CONSTRUCTION AND TRAFFIC HANDLING WORK ONLY

FOR NOTES, ABBREVIATIONS AND LEGEND, SEE SHEET SC-1 AND SC-102

STATE OF CALIFORNIA - DEPARTMENT OF TRANSPORTATION	CONSULTANT	FUNCTIONAL SUPERVISOR	CALCULATED-DESIGNED BY	REVISOR	DATE
	JAMEY VALDIVIA	TIMOTHY J. LEE	ERIN MCPHERSON	JV	9-29-21
	ERIN MCPHERSON				

Dist	COUNTY	ROUTE	POST MILES TOTAL PROJECT	SHEET No.	TOTAL SHEETS
04	Ala, CC	680	R11.0/R21.9, RO.0/RO.9	632	1710
			9-29-21		
REGISTERED CIVIL ENGINEER			DATE		
October 8, 2021			PLANS APPROVAL DATE		
WMH CORPORATION 55 South Market St Suite 1200 San Jose, CA 95113			ALAMEDA CTC 1111 Broadway Suite 800 Oakland, CA 94607		

NOTE:  
FOR ACCURATE RIGHT OF WAY DATA, CONTACT RIGHT OF WAY ENGINEERING AT THE DISTRICT OFFICE.

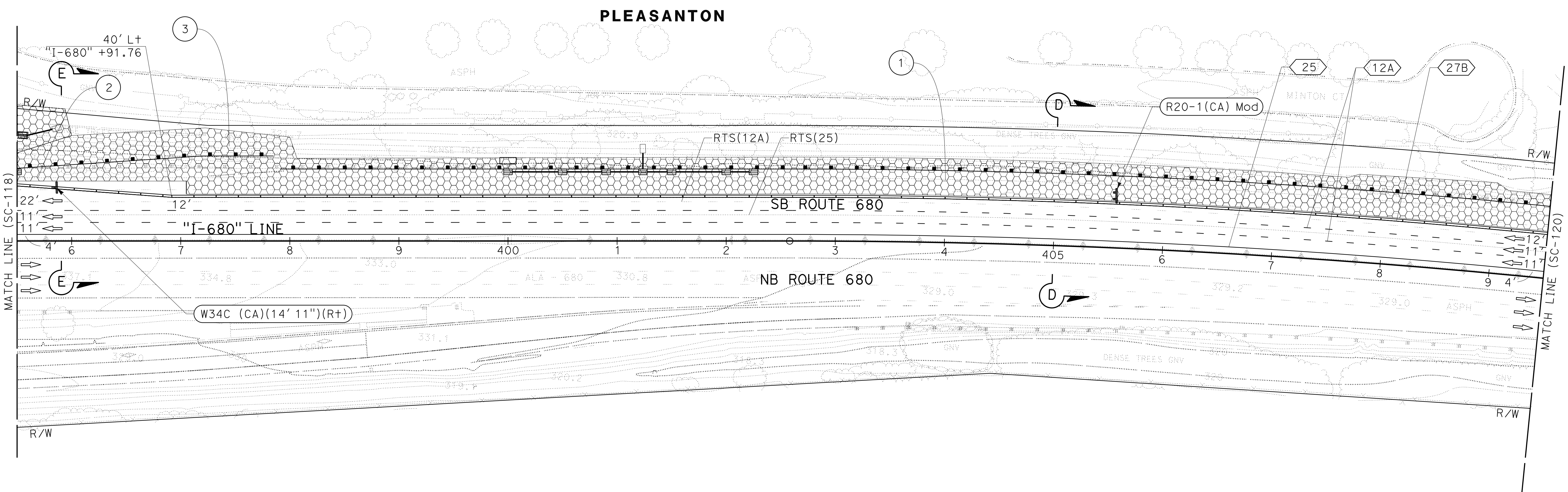
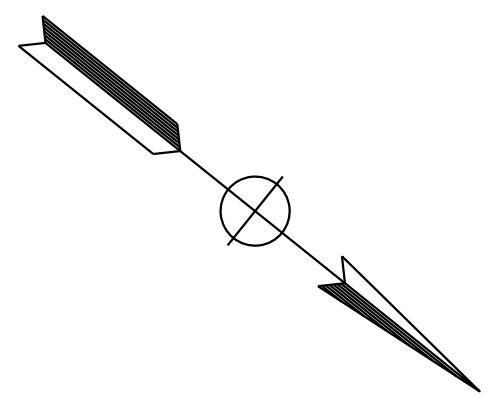

O:\00300\DRAWING\FINAL\_P58E\0420000235ma119.dgn  
 STATE OF CALIFORNIA - DEPARTMENT OF TRANSPORTATION  
 Et Caltrans®  
 CONSULTANT - FUNCTIONAL SUPERVISOR: TIMOTHY J. LEE  
 CALCULATED/DESIGNED BY: JAMEY VALDIVIA  
 CHECKED BY: ERIN MCPHERSON  
 REVISED BY: JV  
 DATE REVISED: 9-29-21  
 DISTRICT: 04, COUNTY: Ala, CC, ROUTE: 680, POST MILES TOTAL PROJECT: R11.0/R21.9, RO.0/RO.9, SHEET No.: 632, TOTAL SHEETS: 1710

FOR NOTES, ABBREVIATIONS AND LEGEND, SEE SHEET SC-1 AND SC-102

APPROVED FOR STAGE CONSTRUCTION AND TRAFFIC HANDLING WORK ONLY

## STAGE CONSTRUCTION AND TRAFFIC HANDLING PLAN STAGE 2

SCALE: 1" = 50'

**SC-119**

LAST REVISION: 09-29-21 | DATE PLOTTED => 8-MAR-2022 | TIME PLOTTED => 10:07

Dist	COUNTY	ROUTE	POST MILES TOTAL PROJECT	SHEET No.	TOTAL SHEETS
04	Ala, CC	680	R11.0/R21.9, R0.0/R0.9	633	1710
			9-29-21		
REGISTERED CIVIL ENGINEER			DATE		
October 8, 2021			PLANS APPROVAL DATE		
WMH CORPORATION 55 South Market St Suite 1200 San Jose, CA 95113			ALAMEDA CTC 1111 Broadway Suite 800 Oakland, CA 94607		

NOTE:  
FOR ACCURATE RIGHT OF WAY DATA, CONTACT RIGHT  
OF WAY ENGINEERING AT THE DISTRICT OFFICE.

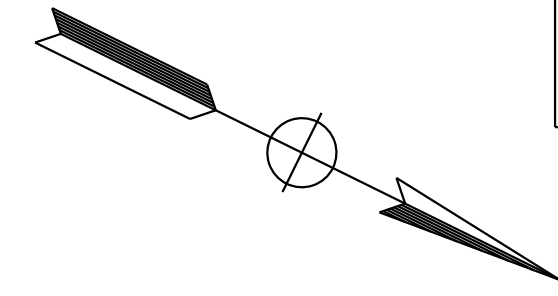

PLEASANTON

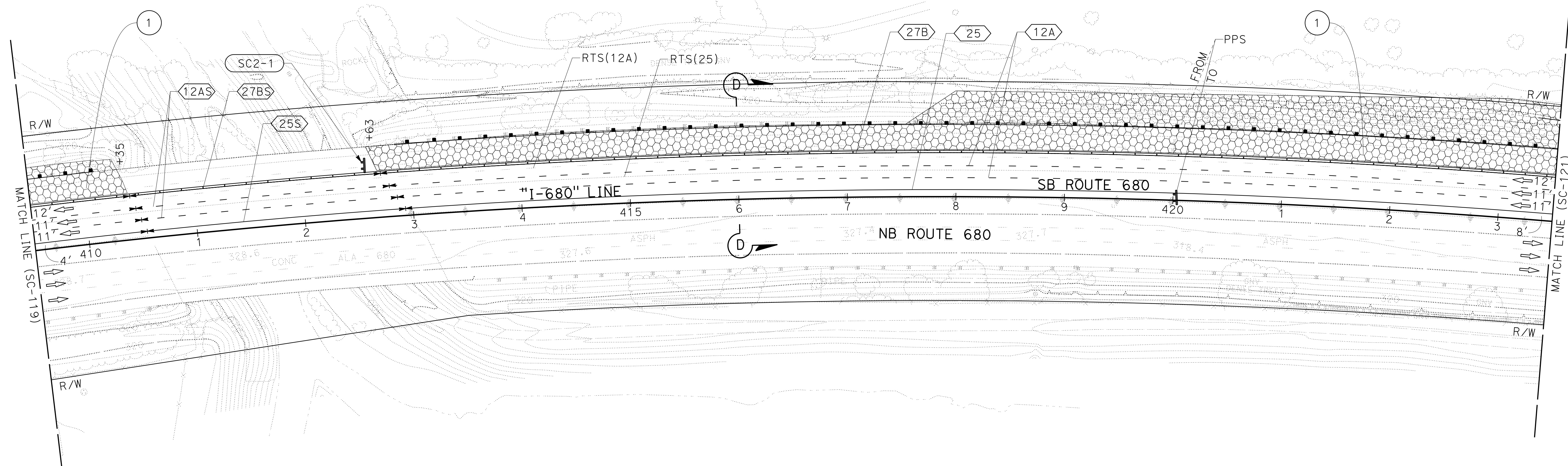

**STAGE CONSTRUCTION  
AND TRAFFIC HANDLING PLAN  
STAGE 2**

SCALE: 1" = 50'

**SC-120**

APPROVED FOR STAGE CONSTRUCTION AND TRAFFIC HANDLING WORK ONLY

FOR NOTES, ABBREVIATIONS AND  
LEGEND, SEE SHEET SC-1 AND SC-102

STATE OF CALIFORNIA - DEPARTMENT OF TRANSPORTATION	CONSULTANT	FUNCTIONAL SUPERVISOR	CALCULATED- DESIGNED BY	CHECKED BY	JAMEY VALDIVIA	REVISOR	DATE
		TIMOTHY J. LEE			ERIN MCPHERSON	JV	9-29-21

O:\00300\DRAWING\FINAL\_P58E\0420000235ma121.dgn  
 STATE OF CALIFORNIA - DEPARTMENT OF TRANSPORTATION  
 Et Caltrans®  
 CONSULTANT: FUNCTIONAL SUPERVISOR: TIMOTHY J. LEE  
 CALCULATED/DESIGNED BY: JAMEY VALDIVIA  
 CHECKED BY: ERIN McPHERSON  
 REVISED BY: JV  
 DATE REVISED: 9-29-21

**NOTE:**  
 FOR ACCURATE RIGHT OF WAY DATA, CONTACT RIGHT OF WAY ENGINEERING AT THE DISTRICT OFFICE.

Dist	COUNTY	ROUTE	POST MILES TOTAL PROJECT	SHEET No.	TOTAL SHEETS
04	Ala, CC	680	R11.0/R21.9, R0.0/R0.9	634	1710

ERIN D. McPHERSON  
 REGISTERED CIVIL ENGINEER  
 DATE: 9-29-21  
 PLANS APPROVAL DATE: October 8, 2021

THE STATE OF CALIFORNIA OR ITS OFFICERS OR AGENTS SHALL NOT BE RESPONSIBLE FOR THE ACCURACY OR COMPLETENESS OF SCANNED COPIES OF THIS PLAN SHEET.

WMH CORPORATION  
 55 South Market St  
 Suite 1200  
 San Jose, CA 95113

ALAMEDA CTC  
 1111 Broadway  
 Suite 800  
 Oakland, CA 94607

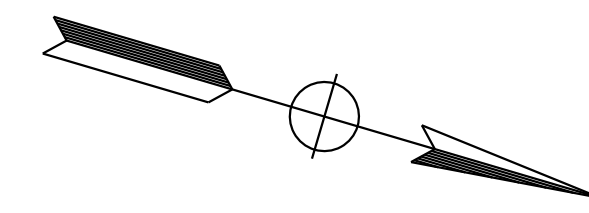

**PLEASANTON**

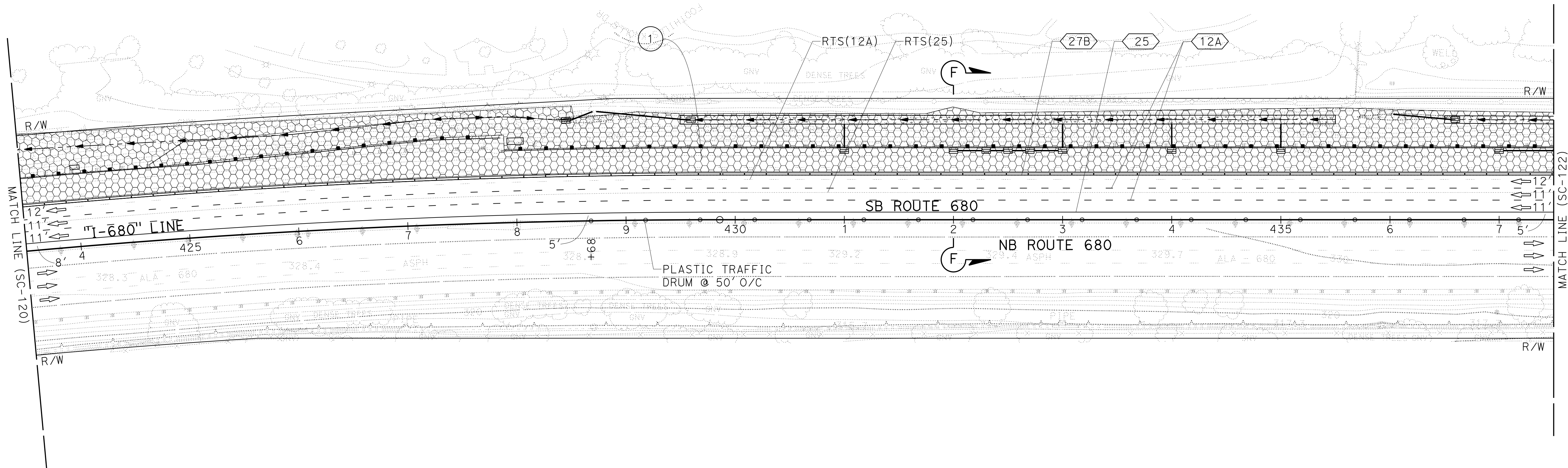

FOR NOTES, ABBREVIATIONS AND LEGEND, SEE SHEET SC-1 AND SC-102

APPROVED FOR STAGE CONSTRUCTION AND TRAFFIC HANDLING WORK ONLY

**STAGE CONSTRUCTION AND TRAFFIC HANDLING PLAN  
 STAGE 2**

SCALE: 1" = 50'

**SC-121**

LAST REVISION: DATE PLOTTED => 8-MAR-2022 | TIME PLOTTED => 10:07

0:\00300\DRAWING\FINAL\_P5&E\0420000235m0122.dgn  
 STATE OF CALIFORNIA - DEPARTMENT OF TRANSPORTATION  
**Caltrans**  
 CONSULTANT - FUNCTIONAL SUPERVISOR: TIMOTHY J. LEE  
 CALCULATED/DESIGNED BY: JAMEY VALDIVIA  
 CHECKED BY: ERIN MCPHERSON  
 REVISED BY: JAV  
 DATE REVISED: 9-29-21

NOTE:  
 FOR ACCURATE RIGHT OF WAY DATA, CONTACT RIGHT OF WAY ENGINEERING AT THE DISTRICT OFFICE.

Dist	COUNTY	ROUTE	POST MILES TOTAL PROJECT	SHEET No.	TOTAL SHEETS
04	Ala, CC	680	R11.0/R21.9, RO.0/RO.9	635	1710
			9-29-21		
REGISTERED CIVIL ENGINEER			DATE		
			October 8, 2021		
			PLANS APPROVAL DATE		
WMH CORPORATION 55 South Market St Suite 1200 San Jose, CA 95113			ALAMEDA CTC 1111 Broadway Suite 800 Oakland, CA 94607		

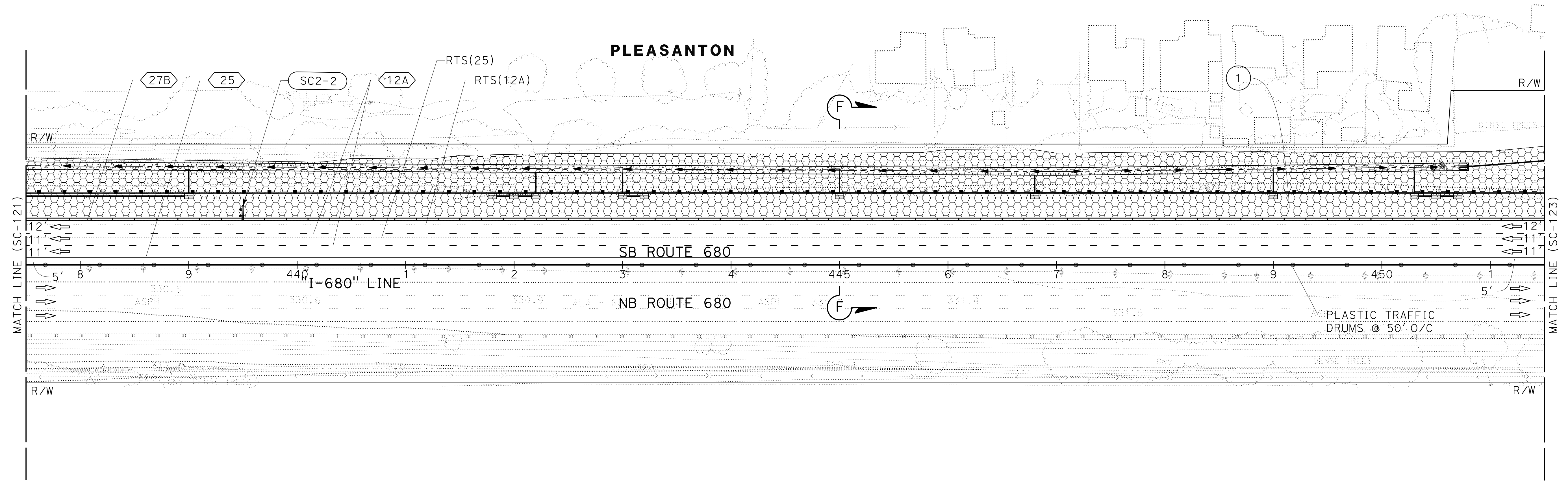
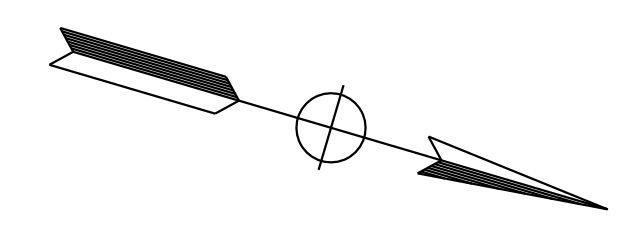

FOR NOTES, ABBREVIATIONS AND LEGEND, SEE SHEET SC-1 AND SC-102

APPROVED FOR STAGE CONSTRUCTION AND TRAFFIC HANDLING WORK ONLY

## STAGE CONSTRUCTION AND TRAFFIC HANDLING PLAN STAGE 2

SCALE: 1" = 50'

**SC-122**

LAST REVISION: 09-29-21 10:07  
 DATE PLOTTED => 8-MAR-2022  
 TIME PLOTTED => 10:07

Dist	COUNTY	ROUTE	POST MILES TOTAL PROJECT	SHEET No.	TOTAL SHEETS
04	Ala, CC	680	R11.0/R21.9, R0.0/R0.9	636	1710
			9-29-21		
REGISTERED CIVIL ENGINEER			DATE		
			October 8, 2021		
			PLANS APPROVAL DATE		
<small>THE STATE OF CALIFORNIA OR ITS OFFICERS OR AGENTS SHALL NOT BE RESPONSIBLE FOR THE ACCURACY OR COMPLETENESS OF SCANNED COPIES OF THIS PLAN SHEET.</small>					
WMH CORPORATION 55 South Market St Suite 1200 San Jose, CA 95113			ALAMEDA CTC 1111 Broadway Suite 800 Oakland, CA 94607		



NOTE:  
FOR ACCURATE RIGHT OF WAY DATA, CONTACT RIGHT OF WAY ENGINEERING AT THE DISTRICT OFFICE.

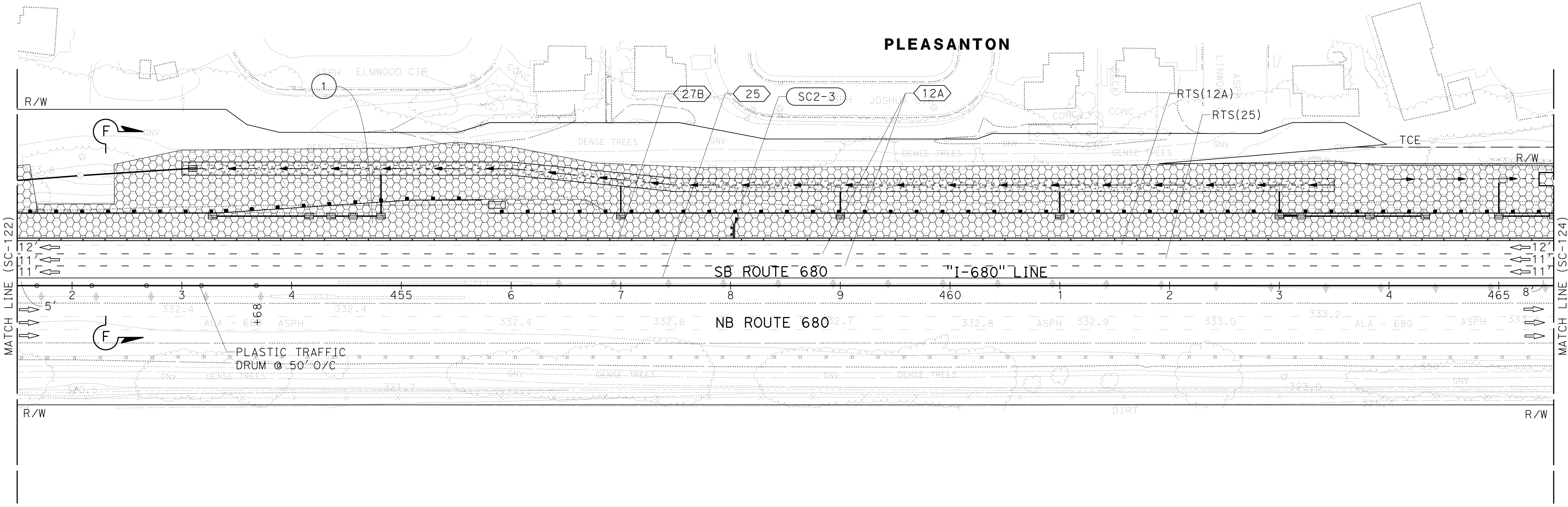
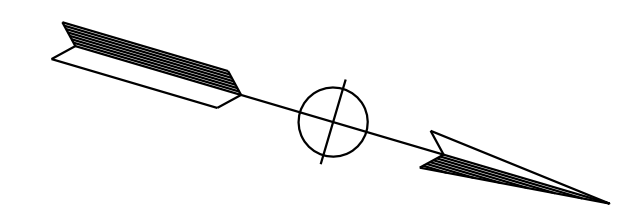

## STAGE CONSTRUCTION AND TRAFFIC HANDLING PLAN STAGE 2

SCALE: 1" = 50'

**SC-123**

APPROVED FOR STAGE CONSTRUCTION AND TRAFFIC HANDLING WORK ONLY

FOR NOTES, ABBREVIATIONS AND  
LEGEND, SEE SHEET SC-1 AND SC-102

O:\00300\DRAWING\FINAL\_P58E\0420000235ma123.dgn  
 STATE OF CALIFORNIA - DEPARTMENT OF TRANSPORTATION  
 Et Caltrans®  
 CONSULTANT - FUNCTIONAL SUPERVISOR: TIMOTHY J. LEE  
 CALCULATED/DESIGNED BY: JAMEY VALDIVIA  
 CHECKED BY: ERIN MCPHERSON  
 REVISED BY: JV  
 DATE REVISED: 9-29-21  
 DISTRICT OFFICE: ALAMEDA COUNTY  
 SHEET NO.: 636  
 TOTAL SHEETS: 1710  
 REGISTERED CIVIL ENGINEER: ERIN D. MCPHERSON  
 DATE: 9-29-21  
 PLANS APPROVAL DATE: October 8, 2021  
 No. C91111  
 Exp. 3-31-24  
 CIVIL  
 THE STATE OF CALIFORNIA OR ITS OFFICERS OR AGENTS SHALL NOT BE RESPONSIBLE FOR THE ACCURACY OR COMPLETENESS OF SCANNED COPIES OF THIS PLAN SHEET.  
 WMH CORPORATION  
 55 South Market St  
 Suite 1200  
 San Jose, CA 95113  
 ALAMEDA CTC  
 1111 Broadway  
 Suite 800  
 Oakland, CA 94607

LAST REVISION: 09-29-21  
 DATE PLOTTED => 8-MAR-2022  
 TIME PLOTTED => 10:07

Dist	COUNTY	ROUTE	POST MILES TOTAL PROJECT	SHEET No.	TOTAL SHEETS
04	Ala, CC	680	R11.0/R21.9, R0.0/R0.9	637	1710
			9-29-21		
REGISTERED CIVIL ENGINEER			DATE		
October 8, 2021			PLANS APPROVAL DATE		
WMH CORPORATION 55 South Market St Suite 1200 San Jose, CA 95113			ALAMEDA CTC 1111 Broadway Suite 800 Oakland, CA 94607		

NOTE:  
FOR ACCURATE RIGHT OF WAY DATA, CONTACT RIGHT OF WAY ENGINEERING AT THE DISTRICT OFFICE.

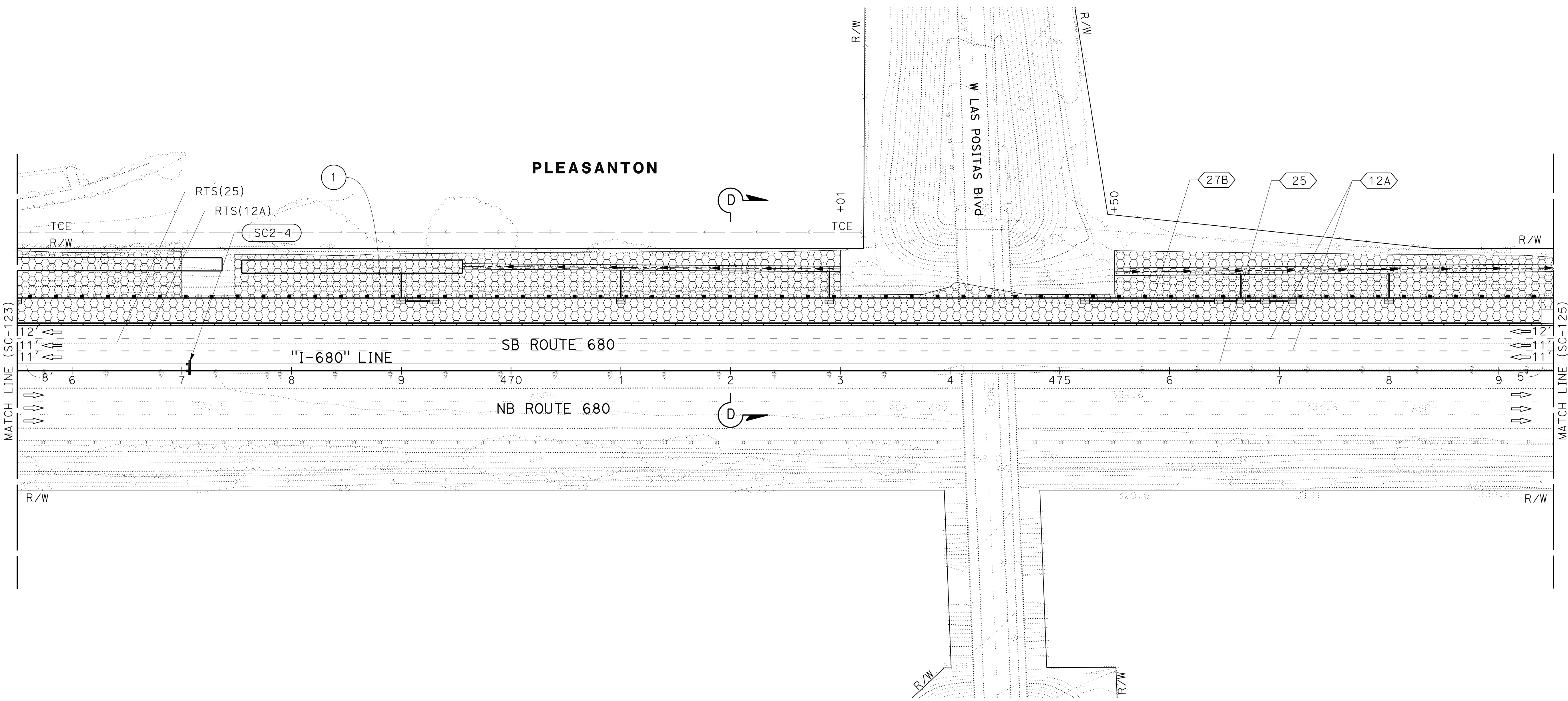
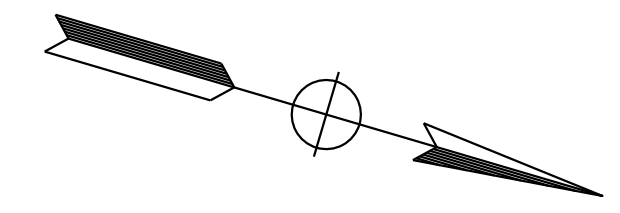

**STAGE CONSTRUCTION  
AND TRAFFIC HANDLING PLAN  
STAGE 2**

SCALE: 1" = 50'

**SC-124**

APPROVED FOR STAGE CONSTRUCTION AND TRAFFIC HANDLING WORK ONLY

FOR NOTES, ABBREVIATIONS AND LEGEND, SEE SHEET SC-1 AND SC-102

STATE OF CALIFORNIA - DEPARTMENT OF TRANSPORTATION	CONSULTANT - FUNCTIONAL SUPERVISOR	REVISOR	DATE
Erwin	TIMOTHY J. LEE	JV	9-29-21
	CHECKED BY	REVISOR	DATE
	ERIN MCPHERSON		
	DESIGNED BY		
	JAMEY VALDIVIA		

Dist	COUNTY	ROUTE	POST MILES TOTAL PROJECT	SHEET No.	TOTAL SHEETS
04	Ala, CC	680	R11.0/R21.9, RO.0/RO.9	638	1710
			9-29-21		
REGISTERED CIVIL ENGINEER			DATE		
October 8, 2021			PLANS APPROVAL DATE		
WMH CORPORATION 55 South Market St Suite 1200 San Jose, CA 95113			ALAMEDA CTC 1111 Broadway Suite 800 Oakland, CA 94607		

NOTE:  
FOR ACCURATE RIGHT OF WAY DATA, CONTACT RIGHT OF WAY ENGINEERING AT THE DISTRICT OFFICE.

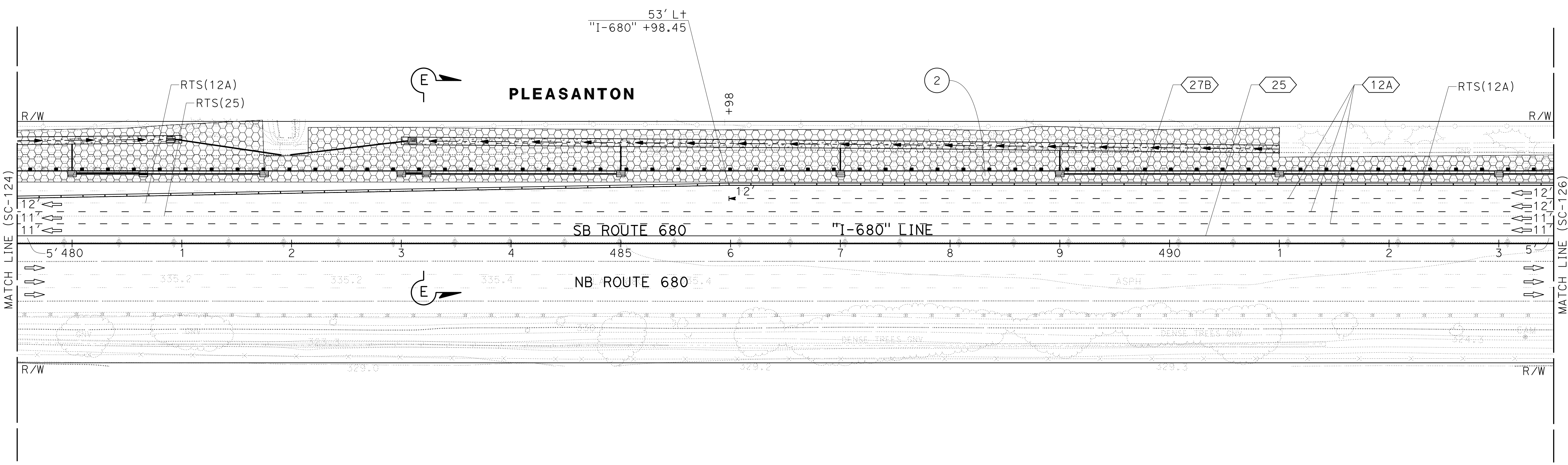
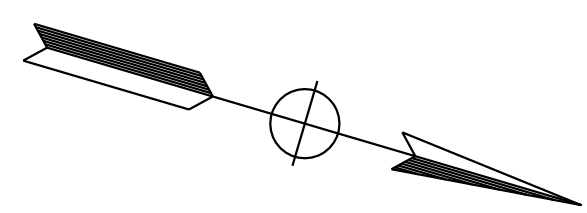

## STAGE CONSTRUCTION AND TRAFFIC HANDLING PLAN STAGE 2

SCALE: 1" = 50'

**SC-125**

APPROVED FOR STAGE CONSTRUCTION AND TRAFFIC HANDLING WORK ONLY

FOR NOTES, ABBREVIATIONS AND LEGEND, SEE SHEET SC-1 AND SC-102

DESIGNED BY	JV
DATE	9-29-21
REVISOR	
DATE	
CHECKED BY	ERIN MCPHERSON
DESIGNED BY	JAMEY VALDIVIA
DATE	
REVISOR	
DATE	
CHECKED BY	TIMOTHY J. LEE
DESIGNED BY	
DATE	
REVISOR	
DATE	
CHECKED BY	
DESIGNED BY	
DATE	
REVISOR	
DATE	
CHECKED BY	

LAST REVISION: 09-29-21 10:07      DATE PLOTTED => 8-MAR-2022      TIME PLOTTED => 10:07

NOTE:  
FOR ACCURATE RIGHT OF WAY DATA, CONTACT RIGHT OF WAY ENGINEERING AT THE DISTRICT OFFICE.

Dist	COUNTY	ROUTE	POST MILES TOTAL PROJECT	SHEET No.	TOTAL SHEETS
04	Ala, CC	680	R11.0/R21.9, RO.0/RO.9	639	1710
			9-29-21		
REGISTERED CIVIL ENGINEER			DATE		
October 8, 2021			PLANS APPROVAL DATE		
WMH CORPORATION 55 South Market St Suite 1200 San Jose, CA 95113			ALAMEDA CTC 1111 Broadway Suite 800 Oakland, CA 94607		

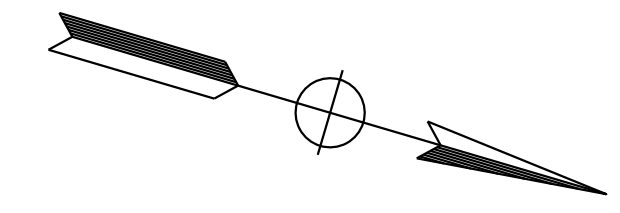

PLEASANTON

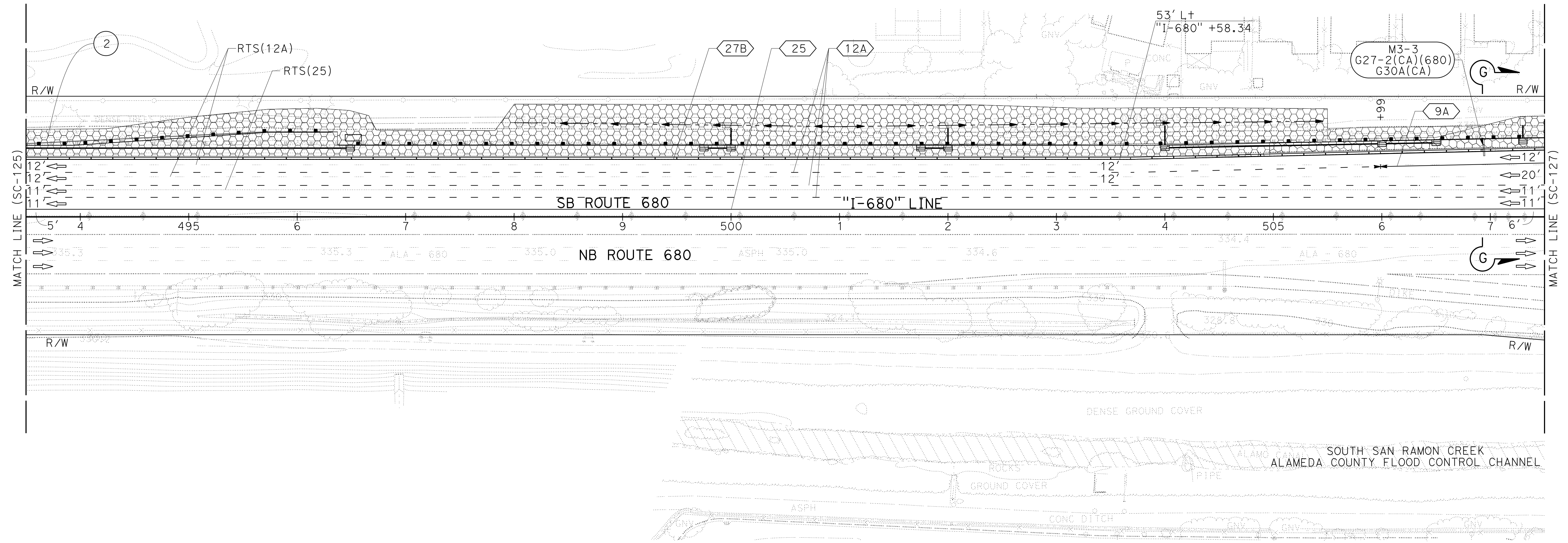

**STAGE CONSTRUCTION AND TRAFFIC HANDLING PLAN**  
**STAGE 2**

SCALE: 1" = 50'

**SC-126**

FOR NOTES, ABBREVIATIONS AND LEGEND, SEE SHEET SC-1 AND SC-102

APPROVED FOR STAGE CONSTRUCTION AND TRAFFIC HANDLING WORK ONLY

O:\00300\DRAWING\FINAL\_P58E\0420000235ma126.dgn  
 STATE OF CALIFORNIA - DEPARTMENT OF TRANSPORTATION  
 Et Caltrans®  
 CONSULTANT - JAMEY VALDIVIA  
 CHECKED BY - ERIN MCPHERSON  
 CALCULATED/DESIGNED BY - JAMEY VALDIVIA  
 SUPERVISOR - TIMOTHY J. LEE  
 REVISED BY - JAV  
 DATE REVISED - 9-29-21

LAST REVISION: DATE PLOTTED => 8-MAR-2022     
 TIME PLOTTED => 10:07

NOTE:  
FOR ACCURATE RIGHT OF WAY DATA, CONTACT RIGHT OF WAY ENGINEERING AT THE DISTRICT OFFICE.

Dist	COUNTY	ROUTE	POST MILES TOTAL PROJECT	SHEET No.	TOTAL SHEETS
04	Ala, CC	680	R11.0/R21.9, RO.0/RO.9	640	1710
			9-29-21		
REGISTERED CIVIL ENGINEER			DATE		
			October 8, 2021		
			PLANS APPROVAL DATE		
WMH CORPORATION 55 South Market St Suite 1200 San Jose, CA 95113			ALAMEDA CTC 1111 Broadway Suite 800 Oakland, CA 94607		

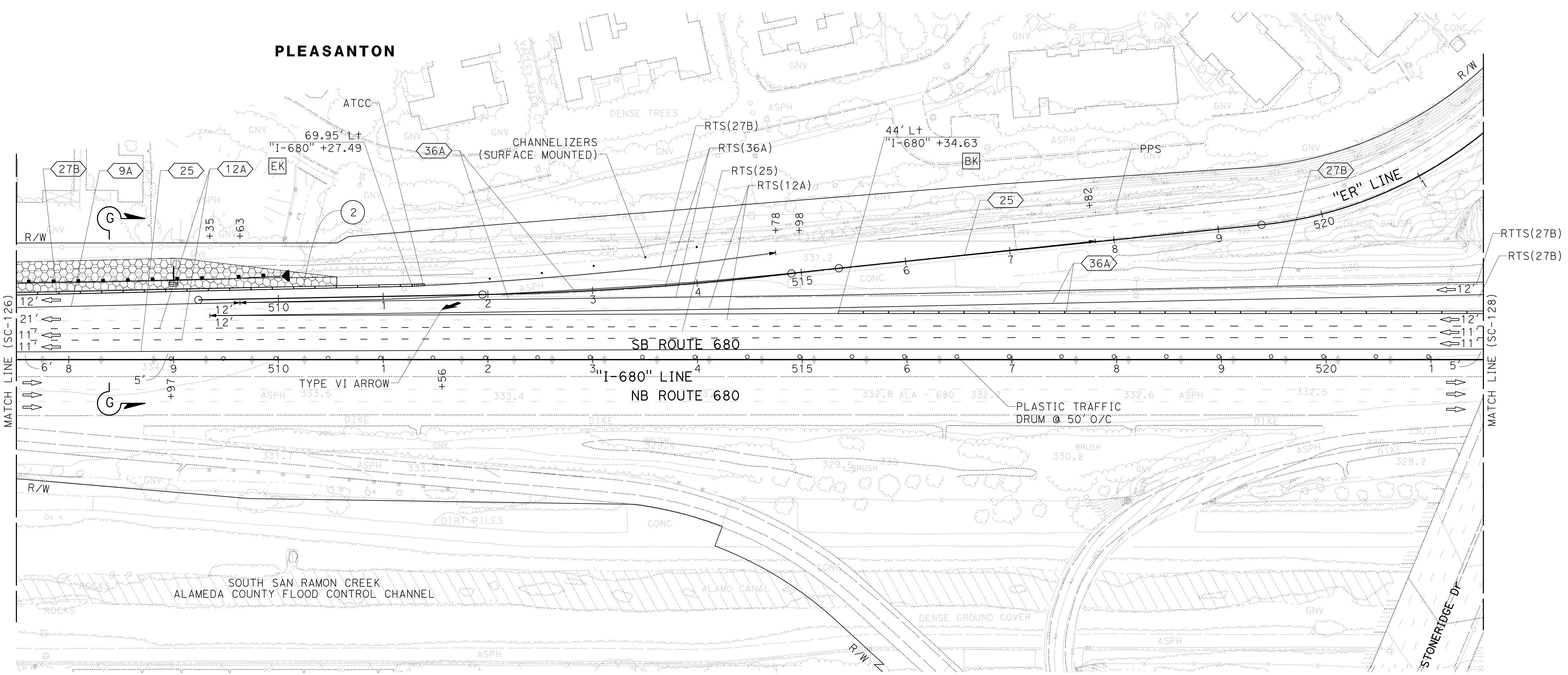
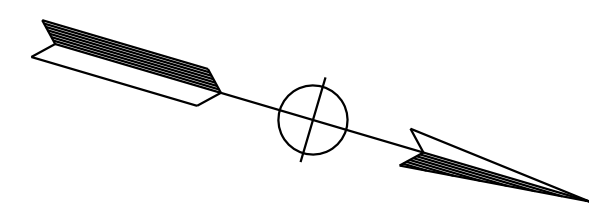

**STAGE CONSTRUCTION  
AND TRAFFIC HANDLING PLAN  
STAGE 2**

SCALE: 1" = 50'

**SC-127**

FOR NOTES, ABBREVIATIONS AND LEGEND, SEE SHEET SC-1 AND SC-102

APPROVED FOR STAGE CONSTRUCTION AND TRAFFIC HANDLING WORK ONLY

O:\0030\UDRAFT\ING\FINAL\_P58E\0420000235ma127.dgn  
 STATE OF CALIFORNIA - DEPARTMENT OF TRANSPORTATION  
 Et Caltrans  
 CONSULTANT - FUNCTIONAL SUPERVISOR: TIMOTHY J. LEE  
 CALCULATED/DESIGNED BY: JAMEY VALDIVIA  
 CHECKED BY: ERIN MCPHERSON  
 REVISED BY: JV  
 DATE REVISED: 9-29-21

LAST REVISION: DATE PLOTTED => 8-MAR-2022  
 09-29-21 TIME PLOTTED => 10:08

Dist	COUNTY	ROUTE	POST MILES TOTAL PROJECT	SHEET No.	TOTAL SHEETS
04	Ala, CC	680	R11.0/R21.9, RO.0/RO.9	641	1710
			9-29-21		
ERIN D. McPHERSON			DATE		
REGISTERED CIVIL ENGINEER					
October 8, 2021			PLANS APPROVAL DATE		
THE STATE OF CALIFORNIA OR ITS OFFICERS OR AGENTS SHALL NOT BE RESPONSIBLE FOR THE ACCURACY OR COMPLETENESS OF SCANNED COPIES OF THIS PLAN SHEET.					
WMH CORPORATION			ALAMEDA CTC		
55 South Market St			1111 Broadway		
Suite 1200			Suite 800		
San Jose, CA 95113			Oakland, CA 94607		



NOTE:  
FOR ACCURATE RIGHT OF WAY DATA, CONTACT RIGHT OF WAY ENGINEERING AT THE DISTRICT OFFICE.

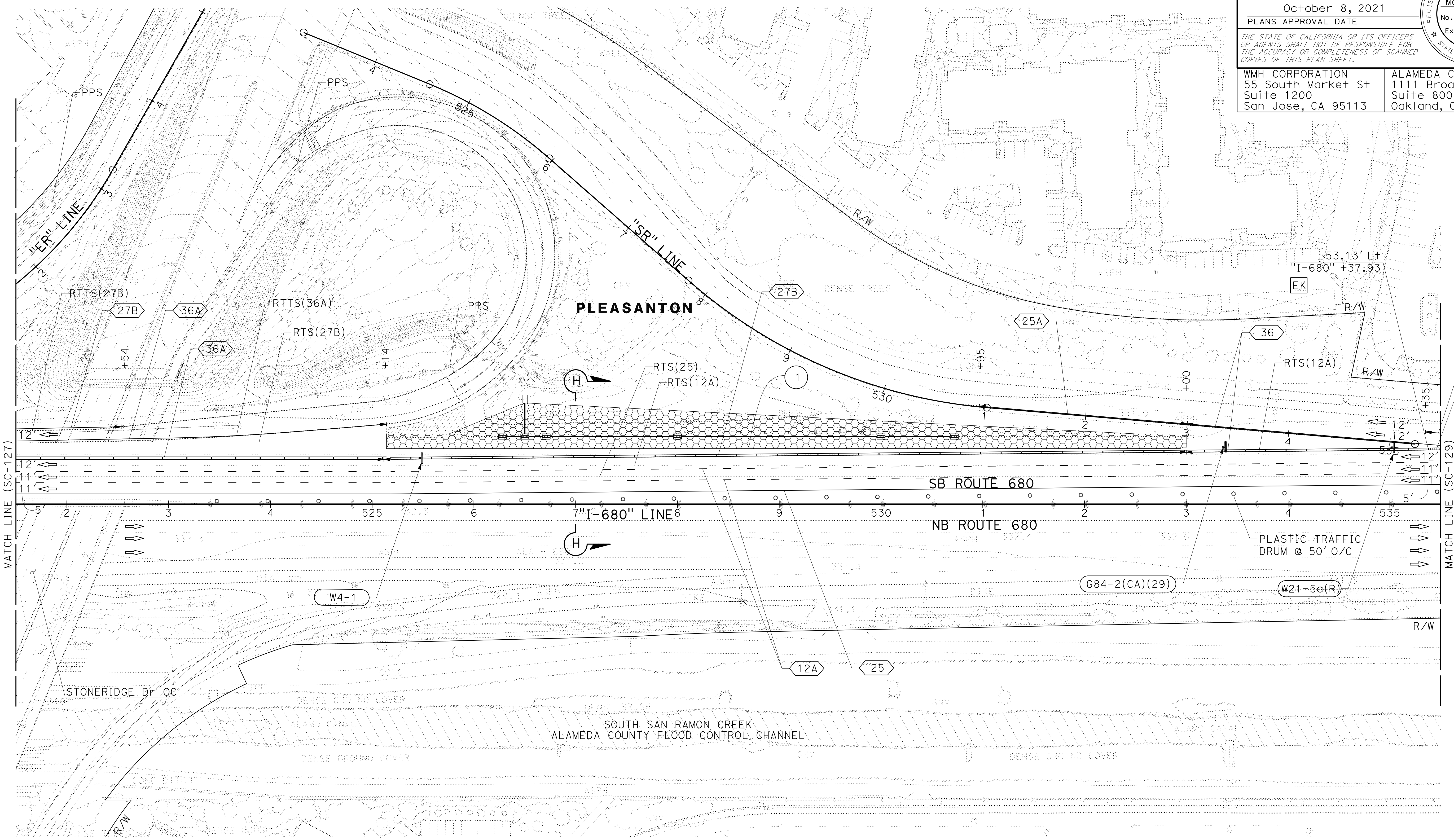

## STAGE CONSTRUCTION AND TRAFFIC HANDLING PLAN STAGE 2

SCALE: 1" = 50'

**SC-128**

APPROVED FOR STAGE CONSTRUCTION AND TRAFFIC HANDLING WORK ONLY

FOR NOTES, ABBREVIATIONS AND LEGEND, SEE SHEET SC-1 AND SC-102

STATE OF CALIFORNIA - DEPARTMENT OF TRANSPORTATION	CONSULTANT	FUNCTIONAL SUPERVISOR	CHECKED BY	DESIGNED BY	REVISOR	DATE
Ervin	JAMES VALDIVIA	JV	ERIN McPHERSON	ERIN McPHERSON	JV	9-29-21
0:\0030\UDRAFT\T\ING\FINAL_P\58E\0420000235ma128.dgn	TIMOTHY J. LEE					

STATE OF CALIFORNIA - DEPARTMENT OF TRANSPORTATION  
 Ervin Corporation  
 CONSULTANT - FUNCTIONAL SUPERVISOR: TIMOTHY J. LEE  
 CHECKED BY: ERIN McPHERSON  
 CALCULATED/DESIGNED BY: JAMEY VALDIVIA  
 REVISED BY: J.V. 9-29-21  
 DATE REVISED: 9-29-21

**NOTE:**  
 FOR ACCURATE RIGHT OF WAY DATA, CONTACT RIGHT OF WAY ENGINEERING AT THE DISTRICT OFFICE.

Dist	COUNTY	ROUTE	POST MILES TOTAL PROJECT	SHEET No.	TOTAL SHEETS
04	Ala, CC	680	R11.0/R21.9, RO.0/RO.9	642	1710

REGISTERED CIVIL ENGINEER: *Erin D. McPherson* 9-29-21  
 DATE: 9-29-21  
 October 8, 2021  
 PLANS APPROVAL DATE: 10-8-21

REGISTERED PROFESSIONAL ENGINEER  
**ERIN D. McPHERSON**  
 No. C91111  
 Exp. 3-31-24  
 CIVIL  
 STATE OF CALIFORNIA

THE STATE OF CALIFORNIA OR ITS OFFICERS OR AGENTS SHALL NOT BE RESPONSIBLE FOR THE ACCURACY OR COMPLETENESS OF SCANNED COPIES OF THIS PLAN SHEET.

WMH CORPORATION 55 South Market St Suite 1200 San Jose, CA 95113	ALAMEDA CTC 1111 Broadway Suite 800 Oakland, CA 94607
---------------------------------------------------------------------------	----------------------------------------------------------------

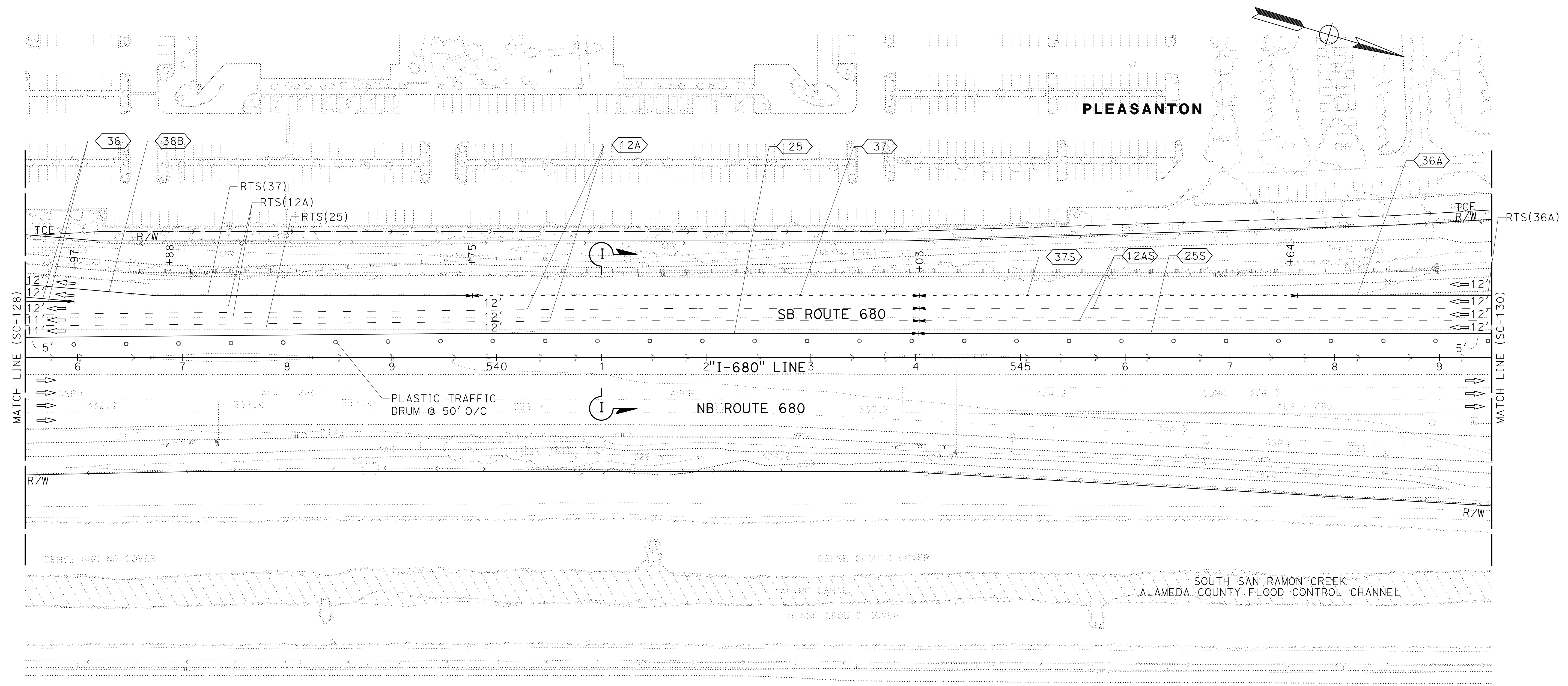

**STAGE CONSTRUCTION  
 AND TRAFFIC HANDLING PLAN  
 STAGE 2**

SCALE: 1" = 50'

**SC-129**

FOR NOTES, ABBREVIATIONS AND LEGEND, SEE SHEET SC-1 AND SC-102

APPROVED FOR STAGE CONSTRUCTION AND TRAFFIC HANDLING WORK ONLY

O:\00300\DRAWING\FINAL\_P58E\0420000235m130.dgn  
 STATE OF CALIFORNIA - DEPARTMENT OF TRANSPORTATION  
**Caltrans**  
 CONSULTANT: JAMEY VALDIVIA  
 SUPERVISOR: TIMOTHY J. LEE  
 DESIGNED BY: ERIN MCPHERSON  
 CHECKED BY:  
 REVISIONS:  
 NO. | DATE | BY | DESCRIPTION  
 1 | 9-29-21 | JV |  
 2 | 9-29-21 | ERIN MCPHERSON |  
 3 | | | |  
 4 | | | |  
 5 | | | |  
 6 | | | |  
 7 | | | |  
 8 | | | |  
 9 | | | |  
 10 | | | |  
 11 | | | |  
 12 | | | |  
 13 | | | |  
 14 | | | |  
 15 | | | |  
 16 | | | |  
 17 | | | |  
 18 | | | |  
 19 | | | |  
 20 | | | |  
 21 | | | |  
 22 | | | |  
 23 | | | |  
 24 | | | |  
 25 | | | |  
 26 | | | |  
 27 | | | |  
 28 | | | |  
 29 | | | |  
 30 | | | |  
 31 | | | |  
 32 | | | |  
 33 | | | |  
 34 | | | |  
 35 | | | |  
 36 | | | |  
 37 | | | |  
 38 | | | |  
 39 | | | |  
 40 | | | |  
 41 | | | |  
 42 | | | |  
 43 | | | |  
 44 | | | |  
 45 | | | |  
 46 | | | |  
 47 | | | |  
 48 | | | |  
 49 | | | |  
 50 | | | |  
 51 | | | |  
 52 | | | |  
 53 | | | |  
 54 | | | |  
 55 | | | |  
 56 | | | |  
 57 | | | |  
 58 | | | |  
 59 | | | |  
 60 | | | |  
 61 | | | |  
 62 | | | |  
 63 | | | |  
 64 | | | |  
 65 | | | |  
 66 | | | |  
 67 | | | |  
 68 | | | |  
 69 | | | |  
 70 | | | |  
 71 | | | |  
 72 | | | |  
 73 | | | |  
 74 | | | |  
 75 | | | |  
 76 | | | |  
 77 | | | |  
 78 | | | |  
 79 | | | |  
 80 | | | |  
 81 | | | |  
 82 | | | |  
 83 | | | |  
 84 | | | |  
 85 | | | |  
 86 | | | |  
 87 | | | |  
 88 | | | |  
 89 | | | |  
 90 | | | |  
 91 | | | |  
 92 | | | |  
 93 | | | |  
 94 | | | |  
 95 | | | |  
 96 | | | |  
 97 | | | |  
 98 | | | |  
 99 | | | |  
 100 | | | |

NOTE:  
 FOR ACCURATE RIGHT OF WAY DATA, CONTACT RIGHT OF WAY ENGINEERING AT THE DISTRICT OFFICE.

Dist	COUNTY	ROUTE	POST MILES TOTAL PROJECT	SHEET No.	TOTAL SHEETS
04	Ala, CC	680	R11.0/R21.9, RO.0/RO.9	643	1710

REGISTERED CIVIL ENGINEER: *Erin McPherson*  
 DATE: 9-29-21  
 PLANS APPROVAL DATE: October 8, 2021

ERIN D. MCPHERSON  
 No. C91111  
 Exp. 3-31-24  
 CIVIL  
 STATE OF CALIFORNIA

WMH CORPORATION  
 55 South Market St  
 Suite 1200  
 San Jose, CA 95113

ALAMEDA CTC  
 1111 Broadway  
 Suite 800  
 Oakland, CA 94607

THE STATE OF CALIFORNIA OR ITS OFFICERS OR AGENTS SHALL NOT BE RESPONSIBLE FOR THE ACCURACY OR COMPLETENESS OF SCANNED COPIES OF THIS PLAN SHEET.

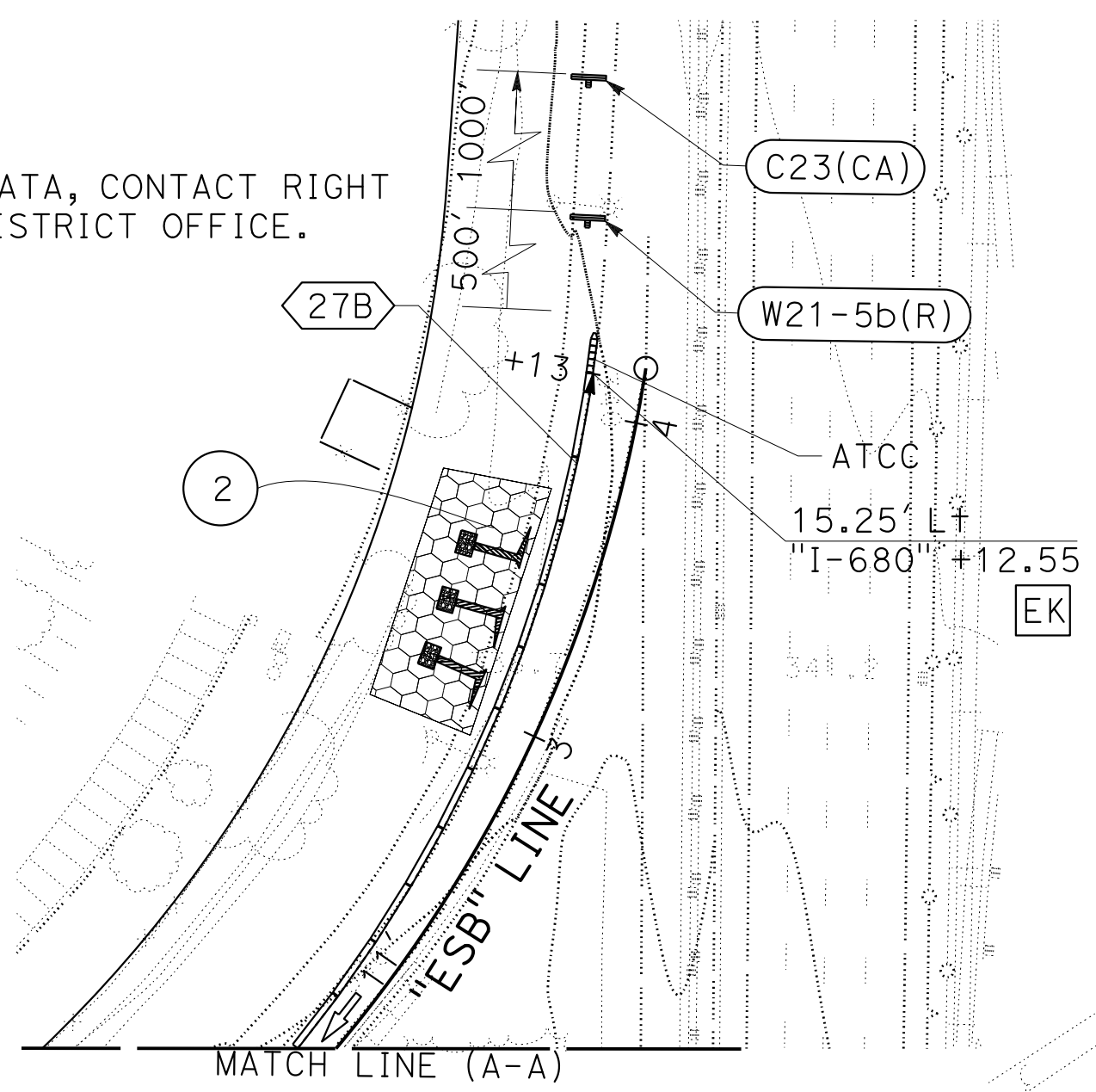
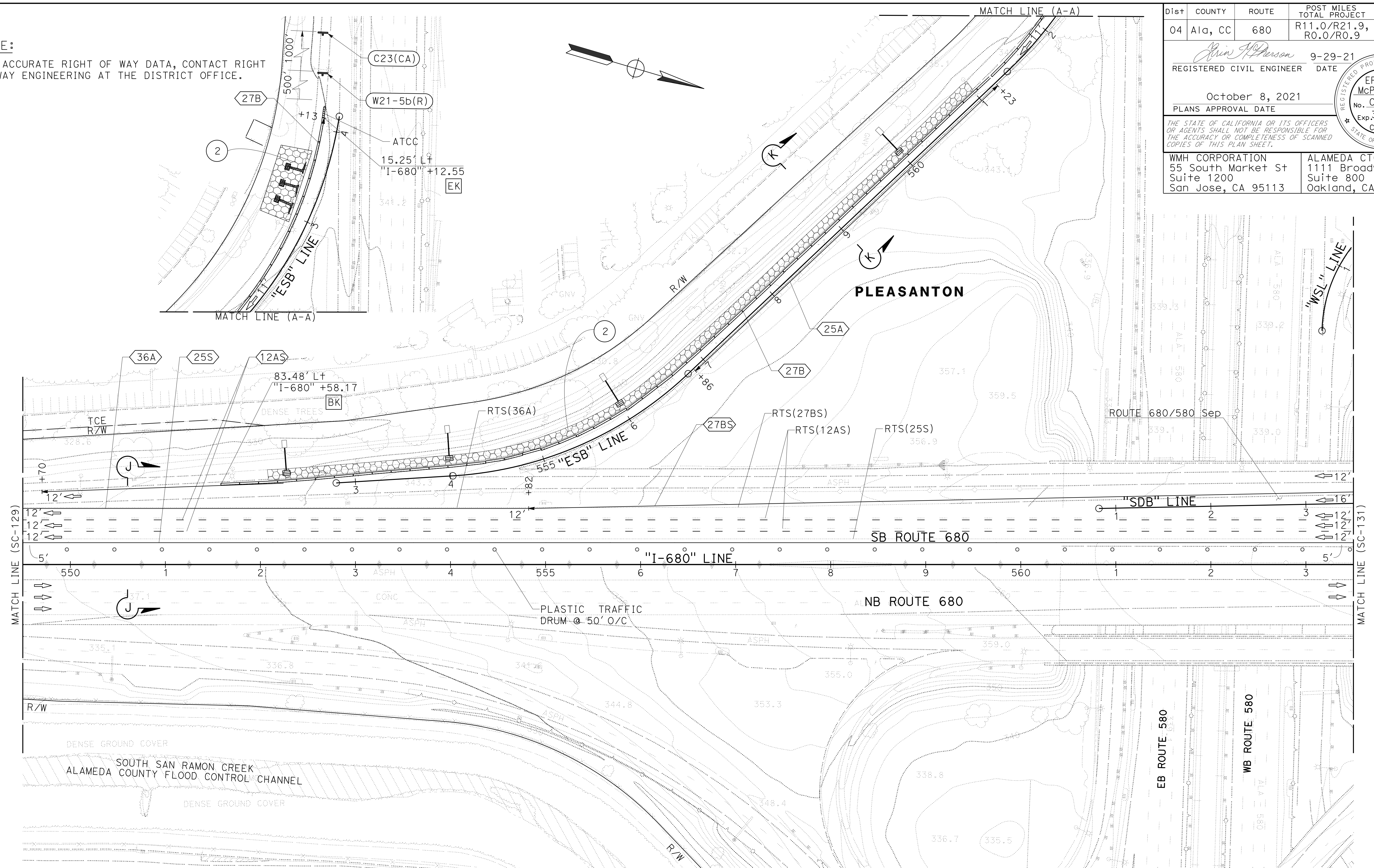



FOR NOTES, ABBREVIATIONS AND LEGEND, SEE SHEET SC-1 AND SC-102

APPROVED FOR STAGE CONSTRUCTION AND TRAFFIC HANDLING WORK ONLY

## STAGE CONSTRUCTION AND TRAFFIC HANDLING PLAN STAGE 2

SCALE: 1" = 50'

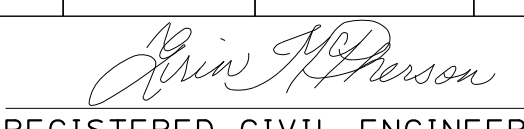
**SC-130**

Dist	COUNTY	ROUTE	POST MILES TOTAL PROJECT	SHEET No.	TOTAL SHEETS
04	Ala, CC	680	R11.0/R21.9, RO.0/RO.9	644	1710
 REGISTERED CIVIL ENGINEER			9-29-21	DATE	
October 8, 2021 PLANS APPROVAL DATE					
WMH CORPORATION 55 South Market St Suite 1200 San Jose, CA 95113			ALAMEDA CTC 1111 Broadway Suite 800 Oakland, CA 94607		

NOTE:  
 FOR ACCURATE RIGHT OF WAY DATA, CONTACT RIGHT OF WAY ENGINEERING AT THE DISTRICT OFFICE.

STATE OF CALIFORNIA - DEPARTMENT OF TRANSPORTATION	CONSULTANT	FUNCTIONAL SUPERVISOR	CALCULATED/DESIGNED BY	REVISOR	DATE
	TIMOTHY J. LEE	JAMEY VALDIVIA	ERIN MCPHERSON	JV	9-29-21

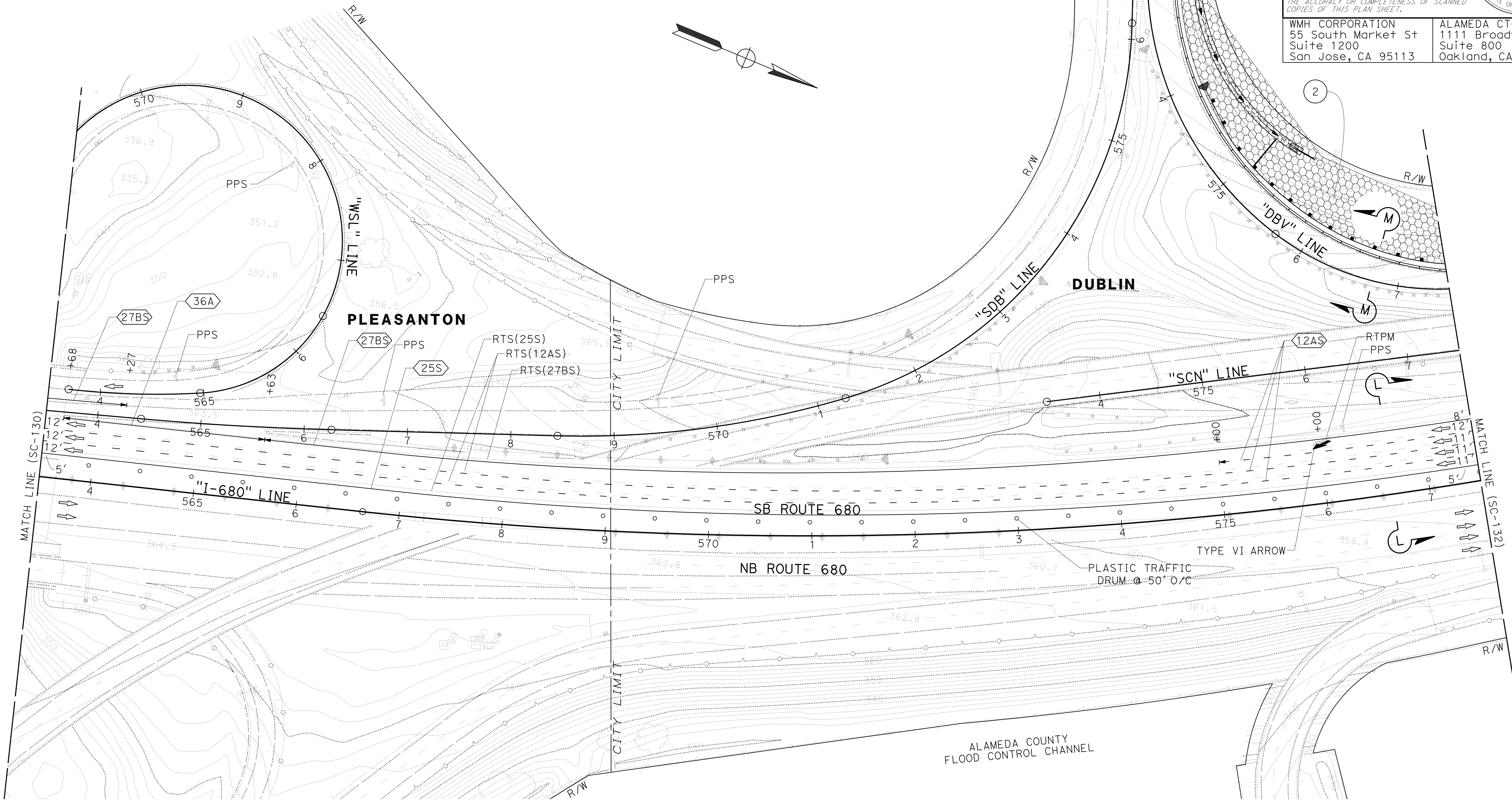

FOR NOTES, ABBREVIATIONS AND LEGEND, SEE SHEET SC-1 AND SC-102

APPROVED FOR STAGE CONSTRUCTION AND TRAFFIC HANDLING WORK ONLY

## STAGE CONSTRUCTION AND TRAFFIC HANDLING PLAN STAGE 2

SCALE: 1" = 50'

**SC-131**

Dist	COUNTY	ROUTE	POST MILES TOTAL PROJECT	SHEET No.	TOTAL SHEETS
04	Ala, CC	680	R11.0/R21.9, RO.0/RO.9	645	1710
			9-29-21	DATE	
REGISTERED CIVIL ENGINEER			DATE		
October 8, 2021			PLANS APPROVAL DATE		
THE STATE OF CALIFORNIA OR ITS OFFICERS OR AGENTS SHALL NOT BE RESPONSIBLE FOR THE ACCURACY OR COMPLETENESS OF SCANNED COPIES OF THIS PLAN SHEET.					
WMH CORPORATION 55 South Market St Suite 1200 San Jose, CA 95113			ALAMEDA CTC 1111 Broadway Suite 800 Oakland, CA 94607		

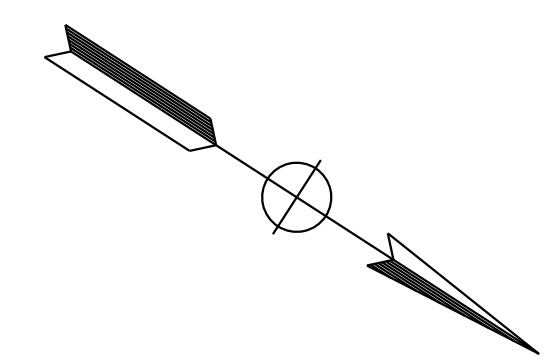

**NOTE:**  
FOR ACCURATE RIGHT OF WAY DATA, CONTACT RIGHT OF WAY ENGINEERING AT THE DISTRICT OFFICE.

DESIGNED BY	JAMEY VALDIVIA
CHECKED BY	ERIN MCPHERSON
CALCULATED-DRAWN BY	ERIN MCPHERSON
FUNCTIONAL SUPERVISOR	TIMOTHY J. LEE
CONSULTANT	DEPARTMENT OF TRANSPORTATION
STATE OF CALIFORNIA	DEPARTMENT OF TRANSPORTATION

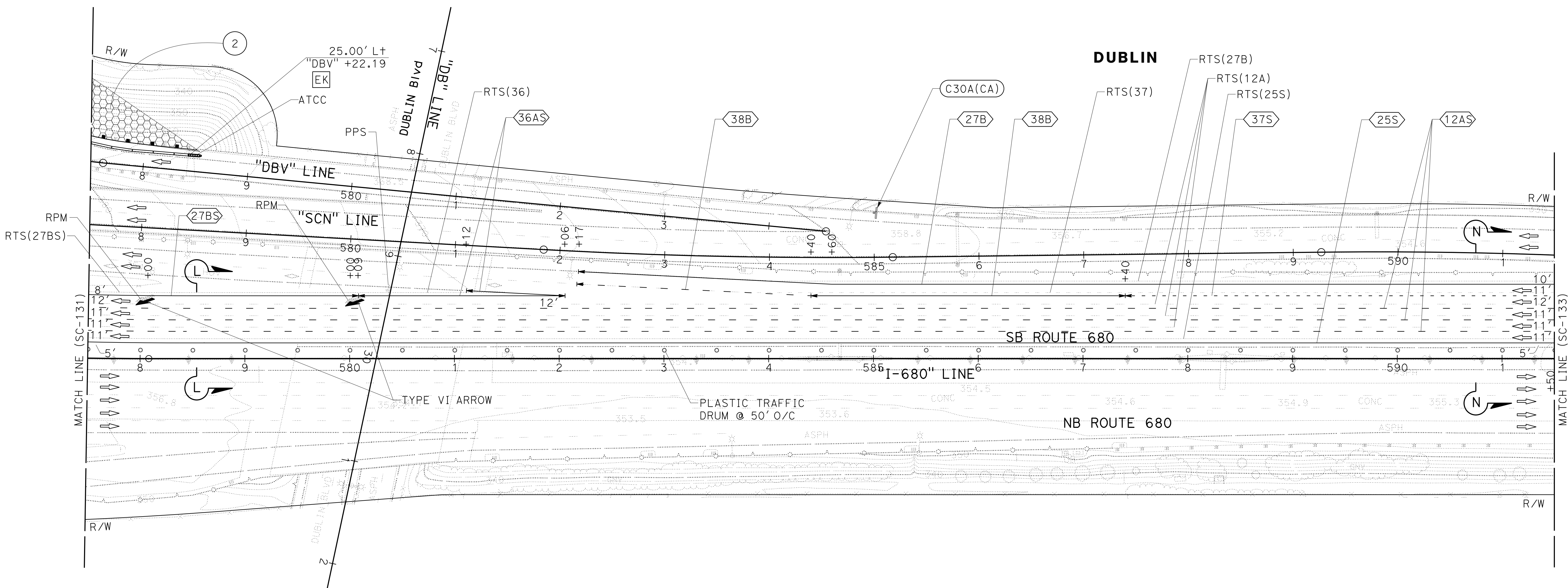

FOR NOTES, ABBREVIATIONS AND LEGEND, SEE SHEET SC-1 AND SC-102

# STAGE CONSTRUCTION AND TRAFFIC HANDLING PLAN STAGE 2

SCALE: 1" = 50'

**SC-132**

APPROVED FOR STAGE CONSTRUCTION AND TRAFFIC HANDLING WORK ONLY



O:\00300\DRAWING\FINAL\_P58E\0420000235ma134.dgn  
 STATE OF CALIFORNIA - DEPARTMENT OF TRANSPORTATION  
 Erwin  
 CONSULTANT FUNCTIONAL SUPERVISOR  
 JAMEY VALDIVIA  
 ERIN McPHERSON  
 CHECKED BY  
 REVISOR  
 DATE  
 9-29-21  
 JV  
 9-29-21

NOTE:  
 FOR ACCURATE RIGHT OF WAY DATA, CONTACT RIGHT OF WAY ENGINEERING AT THE DISTRICT OFFICE.

Dist	COUNTY	ROUTE	POST MILES TOTAL PROJECT	SHEET No.	TOTAL SHEETS
04	Ala, CC	680	R11.0/R21.9, RO.0/RO.9	647	1710
			9-29-21		
REGISTERED CIVIL ENGINEER			DATE		
			October 8, 2021		
			PLANS APPROVAL DATE		
WMH CORPORATION 55 South Market St Suite 1200 San Jose, CA 95113			ALAMEDA CTC 1111 Broadway Suite 800 Oakland, CA 94607		

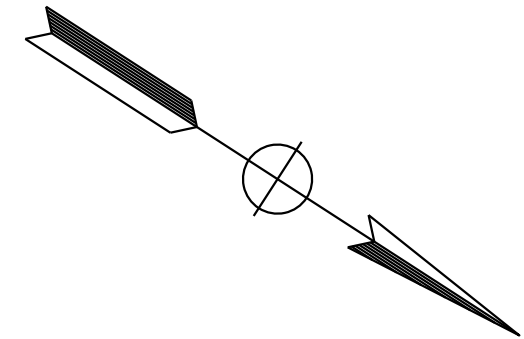

**DUBLIN**

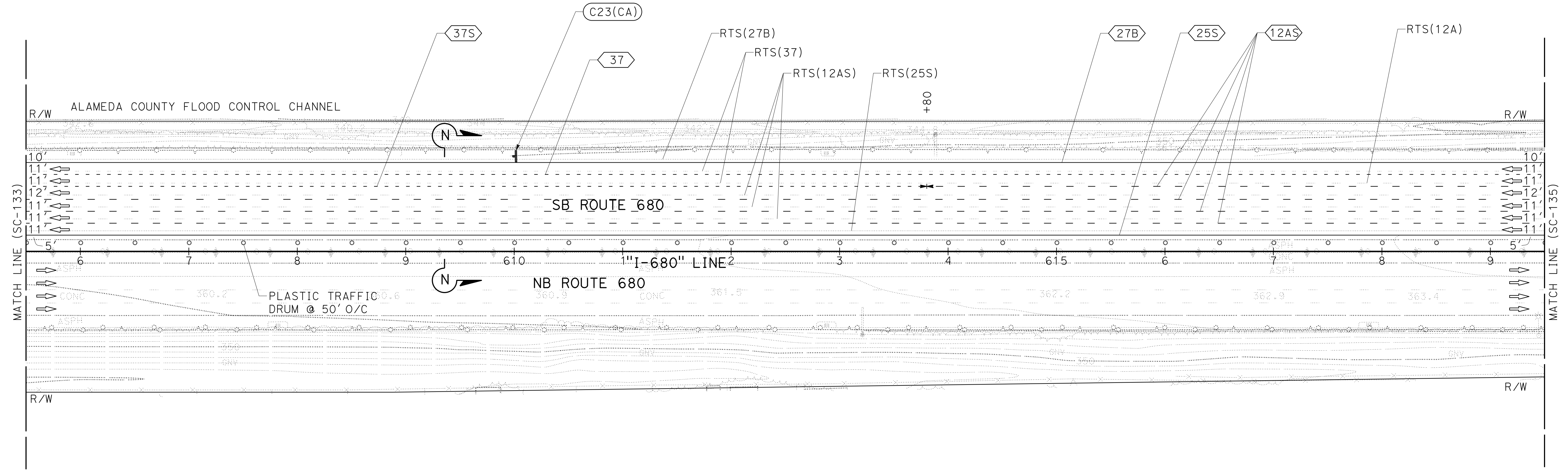

FOR NOTES, ABBREVIATIONS AND LEGEND, SEE SHEET SC-1 AND SC-102

APPROVED FOR STAGE CONSTRUCTION AND TRAFFIC HANDLING WORK ONLY

**STAGE CONSTRUCTION AND TRAFFIC HANDLING PLAN  
 STAGE 2**

SCALE: 1" = 50'

**SC-134**

LAST REVISION: DATE PLOTTED => 8-MAR-2022  
 09-29-21 TIME PLOTTED => 10:08

Dist	COUNTY	ROUTE	POST MILES TOTAL PROJECT	SHEET No.	TOTAL SHEETS
04	Ala, CC	680	R11.0/R21.9, RO.0/RO.9	648	1710
			9-29-21		
REGISTERED CIVIL ENGINEER			DATE		
			October 8, 2021		
			PLANS APPROVAL DATE		
WMH CORPORATION 55 South Market St Suite 1200 San Jose, CA 95113			ALAMEDA CTC 1111 Broadway Suite 800 Oakland, CA 94607		

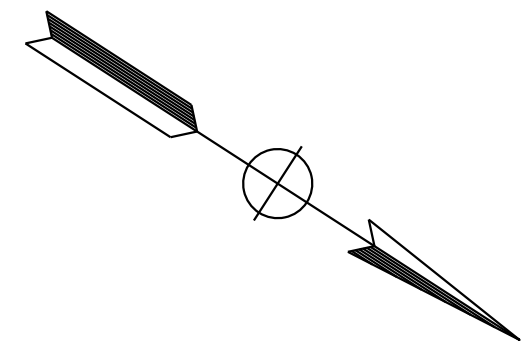

NOTE:  
FOR ACCURATE RIGHT OF WAY DATA, CONTACT RIGHT OF WAY ENGINEERING AT THE DISTRICT OFFICE.

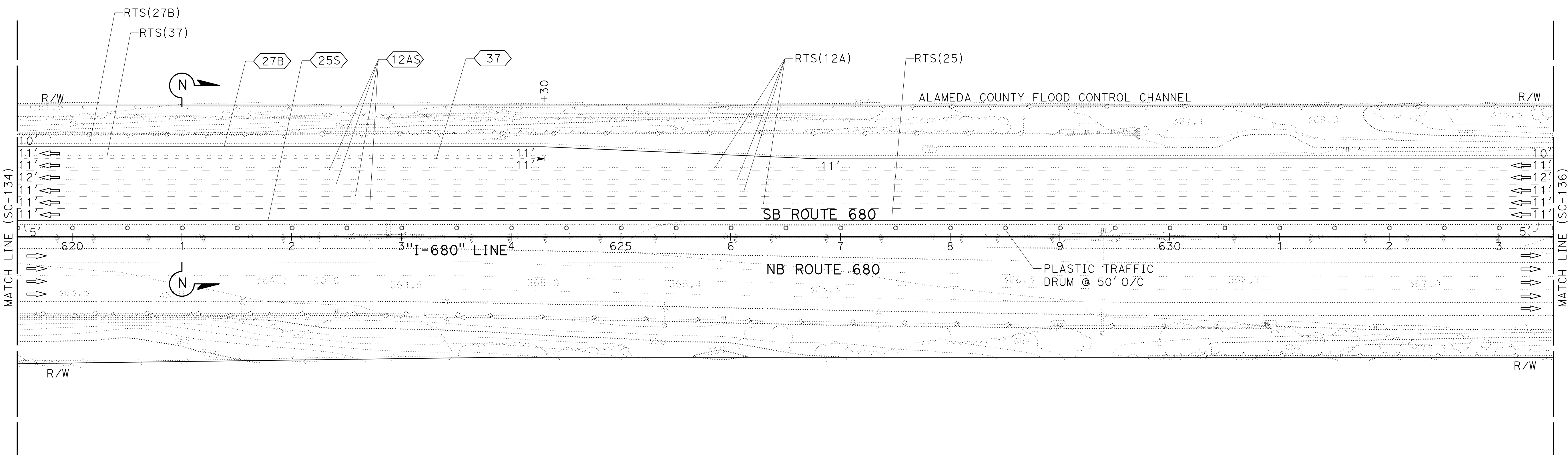

## STAGE CONSTRUCTION AND TRAFFIC HANDLING PLAN STAGE 2

SCALE: 1" = 50'

**SC-135**

APPROVED FOR STAGE CONSTRUCTION AND TRAFFIC HANDLING WORK ONLY

FOR NOTES, ABBREVIATIONS AND LEGEND, SEE SHEET SC-1 AND SC-102

STATE OF CALIFORNIA - DEPARTMENT OF TRANSPORTATION	CONSULTANT	FUNCTIONAL SUPERVISOR	CALCULATED-DESIGNED BY	JAMEY VALDIVIA	REVISOR	DATE
Ernst & Young	TIMOTHY J. LEE	J. LEE	ERIN MCPHERSON	ERIN MCPHERSON	JV	9-29-21

LAST REVISION: 09-29-21 DATE PLOTTED => 8-MAR-2022 TIME PLOTTED => 10:09

STATE OF CALIFORNIA - DEPARTMENT OF TRANSPORTATION  
**Caltrans**  
 CONSULTANT: FUNCTIONAL SUPERVISOR: TIMOTHY J. LEE  
 CALCULATED/DESIGNED BY: JAMEY VALDIVIA  
 CHECKED BY: ERIN MCPHERSON  
 REVISED BY: JAV  
 DATE REVISED: 9-29-21

**NOTE:**  
 FOR ACCURATE RIGHT OF WAY DATA, CONTACT RIGHT OF WAY ENGINEERING AT THE DISTRICT OFFICE.

Dist	COUNTY	ROUTE	POST MILES TOTAL PROJECT	SHEET No.	TOTAL SHEETS
04	Ala, CC	680	R11.0/R21.9, RO.0/RO.9	649	1710

REGISTERED CIVIL ENGINEER: *Erin D. McPherson* DATE: 9-29-21  
 PLANS APPROVAL DATE: October 8, 2021  
 REGISTERED PROFESSIONAL ENGINEER: ERIN D. MCPHERSON  
 No. C91111  
 Exp. 3-31-24  
 CIVIL  
 STATE OF CALIFORNIA  
THE STATE OF CALIFORNIA OR ITS OFFICERS OR AGENTS SHALL NOT BE RESPONSIBLE FOR THE ACCURACY OR COMPLETENESS OF SCANNED COPIES OF THIS PLAN SHEET.

WMH CORPORATION 55 South Market St Suite 1200 San Jose, CA 95113	ALAMEDA CTC 1111 Broadway Suite 800 Oakland, CA 94607
---------------------------------------------------------------------------	----------------------------------------------------------------

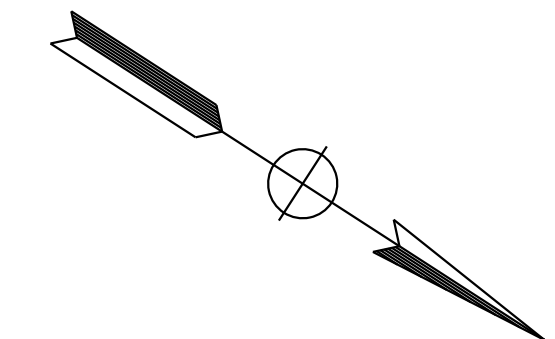

**DUBLIN**

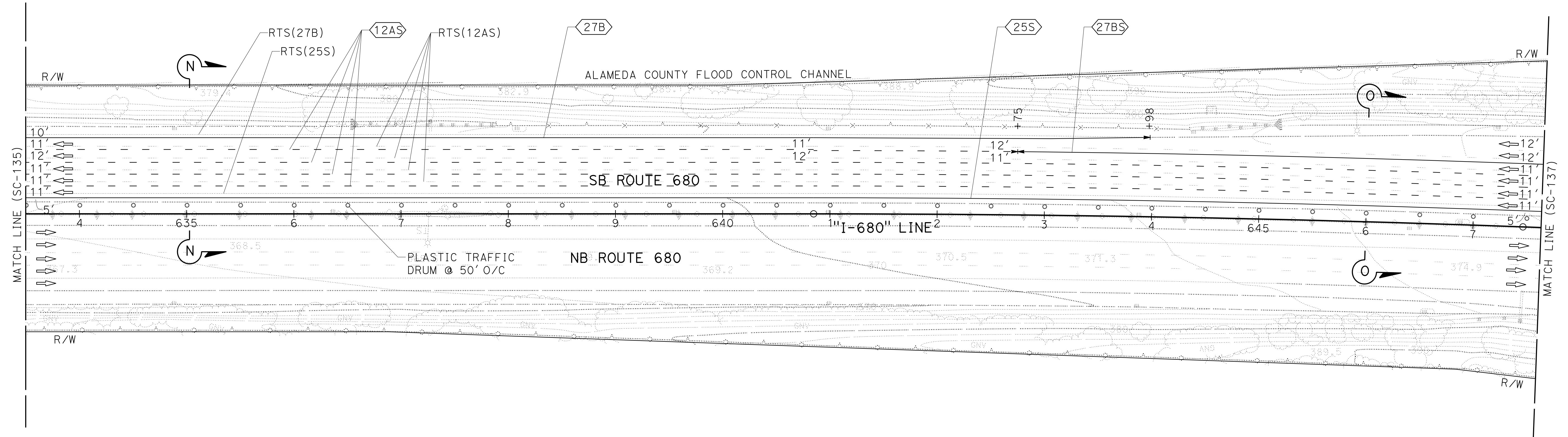

**STAGE CONSTRUCTION AND TRAFFIC HANDLING PLAN  
 STAGE 2**

SCALE: 1" = 50'

**SC-136**

FOR NOTES, ABBREVIATIONS AND LEGEND, SEE SHEET SC-1 AND SC-102

APPROVED FOR STAGE CONSTRUCTION AND TRAFFIC HANDLING WORK ONLY

LAST REVISION: DATE PLOTTED => 8-MAR-2022 09-29-21 TIME PLOTTED => 10:09

Dist	COUNTY	ROUTE	POST MILES TOTAL PROJECT	SHEET No.	TOTAL SHEETS
04	Ala, CC	680	R11.0/R21.9, RO.0/RO.9	650	1710
			9-29-21		
REGISTERED CIVIL ENGINEER			DATE		
October 8, 2021			PLANS APPROVAL DATE		
THE STATE OF CALIFORNIA OR ITS OFFICERS OR AGENTS SHALL NOT BE RESPONSIBLE FOR THE ACCURACY OR COMPLETENESS OF SCANNED COPIES OF THIS PLAN SHEET.					
WMH CORPORATION 55 South Market St Suite 1200 San Jose, CA 95113			ALAMEDA CTC 1111 Broadway Suite 800 Oakland, CA 94607		



NOTE:  
FOR ACCURATE RIGHT OF WAY DATA, CONTACT RIGHT OF WAY ENGINEERING AT THE DISTRICT OFFICE.

O:\00300\DRAWING\FINAL\_P58E\0420000235ma137.dgn  
 STATE OF CALIFORNIA - DEPARTMENT OF TRANSPORTATION  
 Er Catrans  
 CONSULTANT SUPERVISOR: JIMMY J. LEE  
 CHECKED BY: ERIN MCPHERSON  
 REVISIONS: 9-29-21  
 DATE: 9-29-21

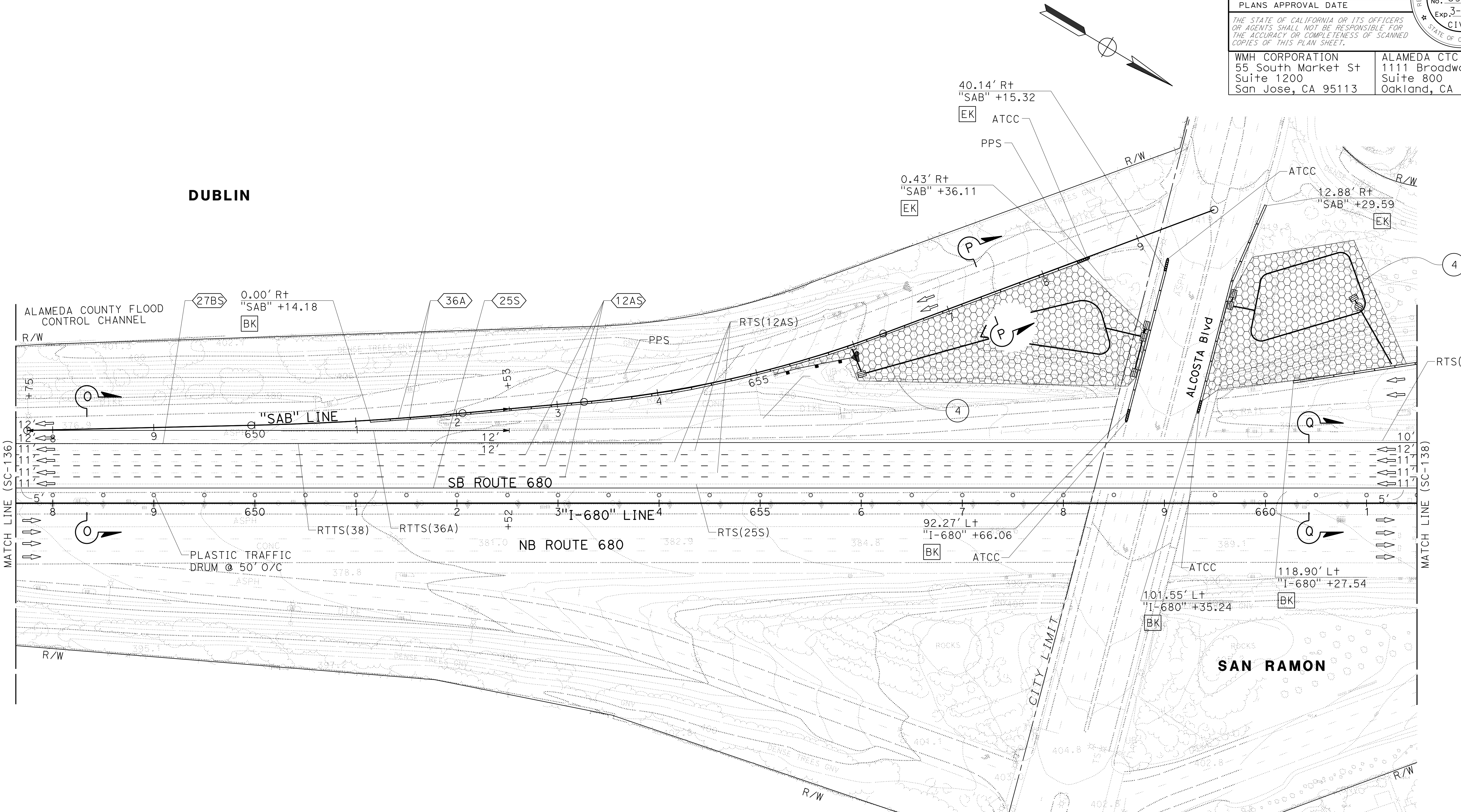

**STAGE CONSTRUCTION AND TRAFFIC HANDLING PLAN**  
**STAGE 2**

SCALE: 1" = 50'

**SC-137**

FOR NOTES, ABBREVIATIONS AND LEGEND, SEE SHEET SC-1 AND SC-102

APPROVED FOR STAGE CONSTRUCTION AND TRAFFIC HANDLING WORK ONLY

LAST REVISION: 09-29-21      DATE PLOTTED => 8-MAR-2022      TIME PLOTTED => 10:09

Dist	COUNTY	ROUTE	POST MILES TOTAL PROJECT	SHEET No.	TOTAL SHEETS
04	Ala, CC	680	R11.0/R21.9, RO.0/RO.9	651	1710
			9-29-21		
REGISTERED CIVIL ENGINEER			DATE		
October 8, 2021			PLANS APPROVAL DATE		
WMH CORPORATION 55 South Market St Suite 1200 San Jose, CA 95113			ALAMEDA CTC 1111 Broadway Suite 800 Oakland, CA 94607		

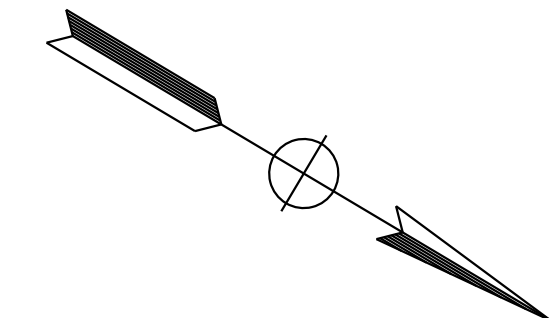

NOTE:  
FOR ACCURATE RIGHT OF WAY DATA, CONTACT RIGHT OF WAY ENGINEERING AT THE DISTRICT OFFICE.

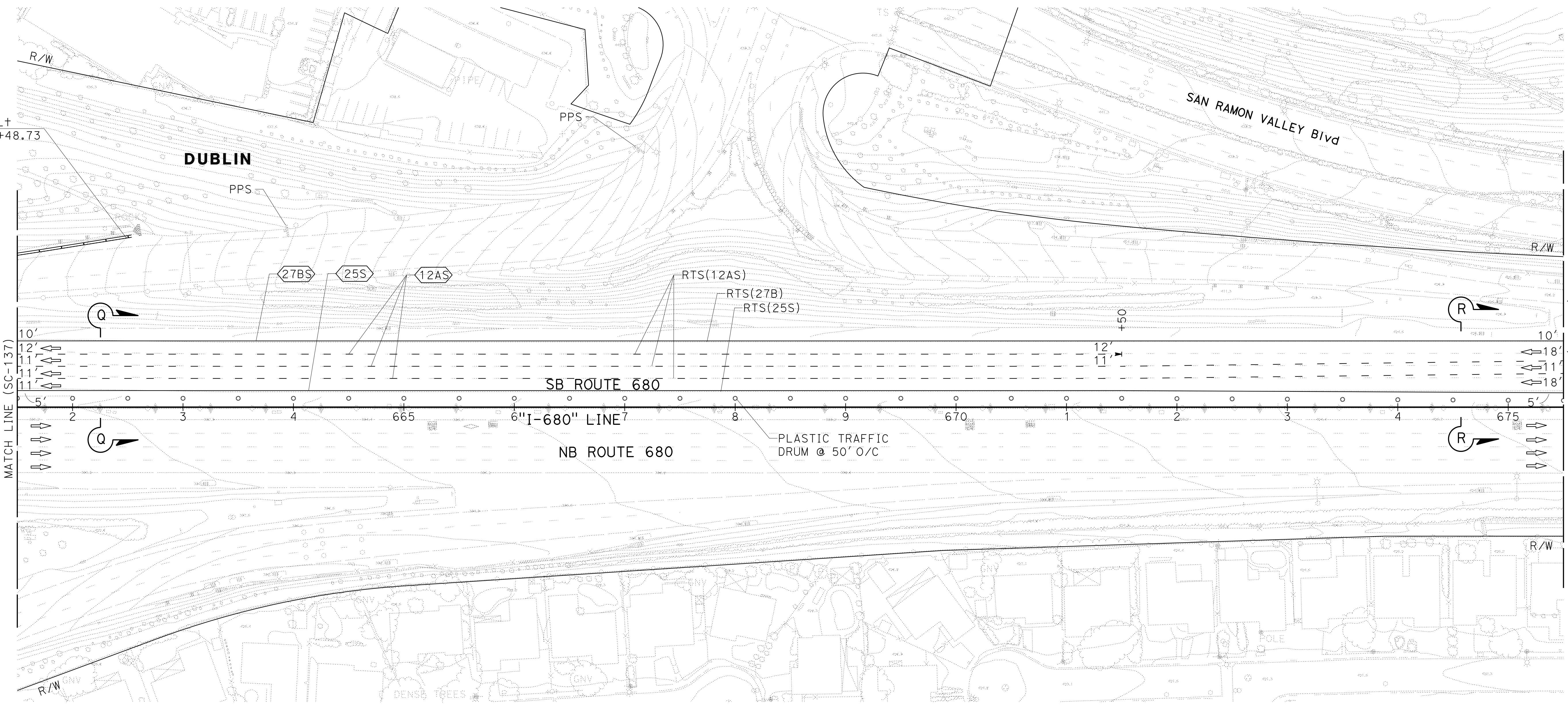

## STAGE CONSTRUCTION AND TRAFFIC HANDLING PLAN STAGE 2

SCALE: 1" = 50'

**SC-138**

FOR NOTES, ABBREVIATIONS AND LEGEND, SEE SHEET SC-1 AND SC-102

APPROVED FOR STAGE CONSTRUCTION AND TRAFFIC HANDLING WORK ONLY

STATE OF CALIFORNIA - DEPARTMENT OF TRANSPORTATION	CONSULTANT - FUNCTIONAL SUPERVISOR	REVISOR	DATE
Erwin McPherson	JAMES VALDIVIA	JV	9-29-21
Erwin McPherson	ERIN MCPHERSON		
Erwin McPherson	TIMOTHY J. LEE		

Dist	COUNTY	ROUTE	POST MILES TOTAL PROJECT	SHEET No.	TOTAL SHEETS
04	Ala, CC	680	R11.0/R21.9, R0.0/R0.9	652	1710

 REGISTERED CIVIL ENGINEER	9-29-21 DATE
October 8, 2021 PLANS APPROVAL DATE	

  

ERIN D. McPHERSON No. C91111 Exp. 3-31-24 CIVIL STATE OF CALIFORNIA
------------------------------------------------------------------------------------

WMH CORPORATION 55 South Market St Suite 1200 San Jose, CA 95113	ALAMEDA CTC 1111 Broadway Suite 800 Oakland, CA 94607
---------------------------------------------------------------------------	----------------------------------------------------------------

NOTE:  
FOR ACCURATE RIGHT OF WAY DATA, CONTACT RIGHT OF WAY ENGINEERING AT THE DISTRICT OFFICE.

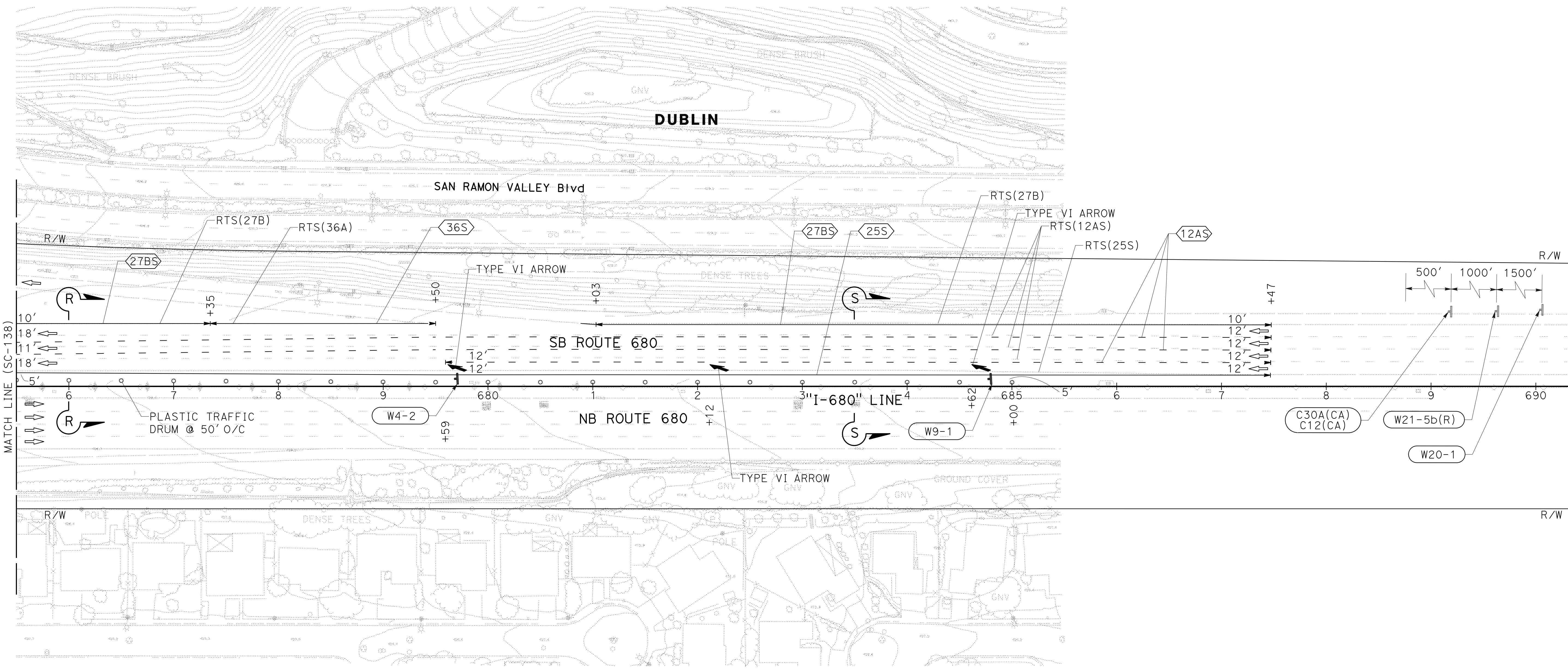
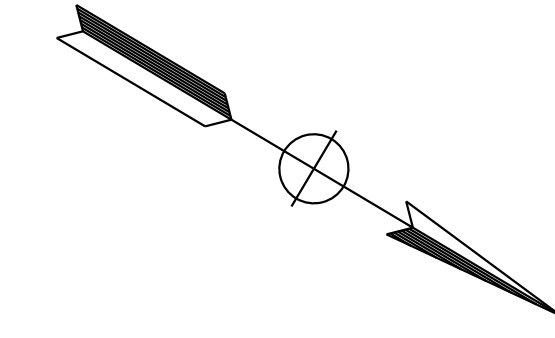

**STAGE CONSTRUCTION  
AND TRAFFIC HANDLING PLAN  
STAGE 2**

SCALE: 1" = 50'

**SC-139**

FOR NOTES, ABBREVIATIONS AND LEGEND, SEE SHEET SC-1 AND SC-102

APPROVED FOR STAGE CONSTRUCTION AND TRAFFIC HANDLING WORK ONLY

STATE OF CALIFORNIA - DEPARTMENT OF TRANSPORTATION	CONSULTANT - FUNCTIONAL SUPERVISOR	REVISOR	DATE
 STATE OF CALIFORNIA - DEPARTMENT OF TRANSPORTATION	TIMOTHY J. LEE	JV	9-29-21
	CHECKED BY	DESIGNED BY	
	ERIN McPHERSON	JAMEY VALDIVIA	

LAST REVISION: 09-29-21 DATE PLOTTED => 8-MAR-2022 TIME PLOTTED => 10:09

Dist	COUNTY	ROUTE	POST MILES TOTAL PROJECT	SHEET No.	TOTAL SHEETS
04	Ala, CC	680	R11.0/R21.9, RO.0/RO.9	653	1710
			9-29-21		
REGISTERED CIVIL ENGINEER			DATE		
October 8, 2021			PLANS APPROVAL DATE		
<small>THE STATE OF CALIFORNIA OR ITS OFFICERS OR AGENTS SHALL NOT BE RESPONSIBLE FOR THE ACCURACY OR COMPLETENESS OF SCANNED COPIES OF THIS PLAN SHEET.</small>					
WMH CORPORATION 55 South Market St Suite 1200 San Jose, CA 95113			ALAMEDA CTC 1111 Broadway Suite 800 Oakland, CA 94607		

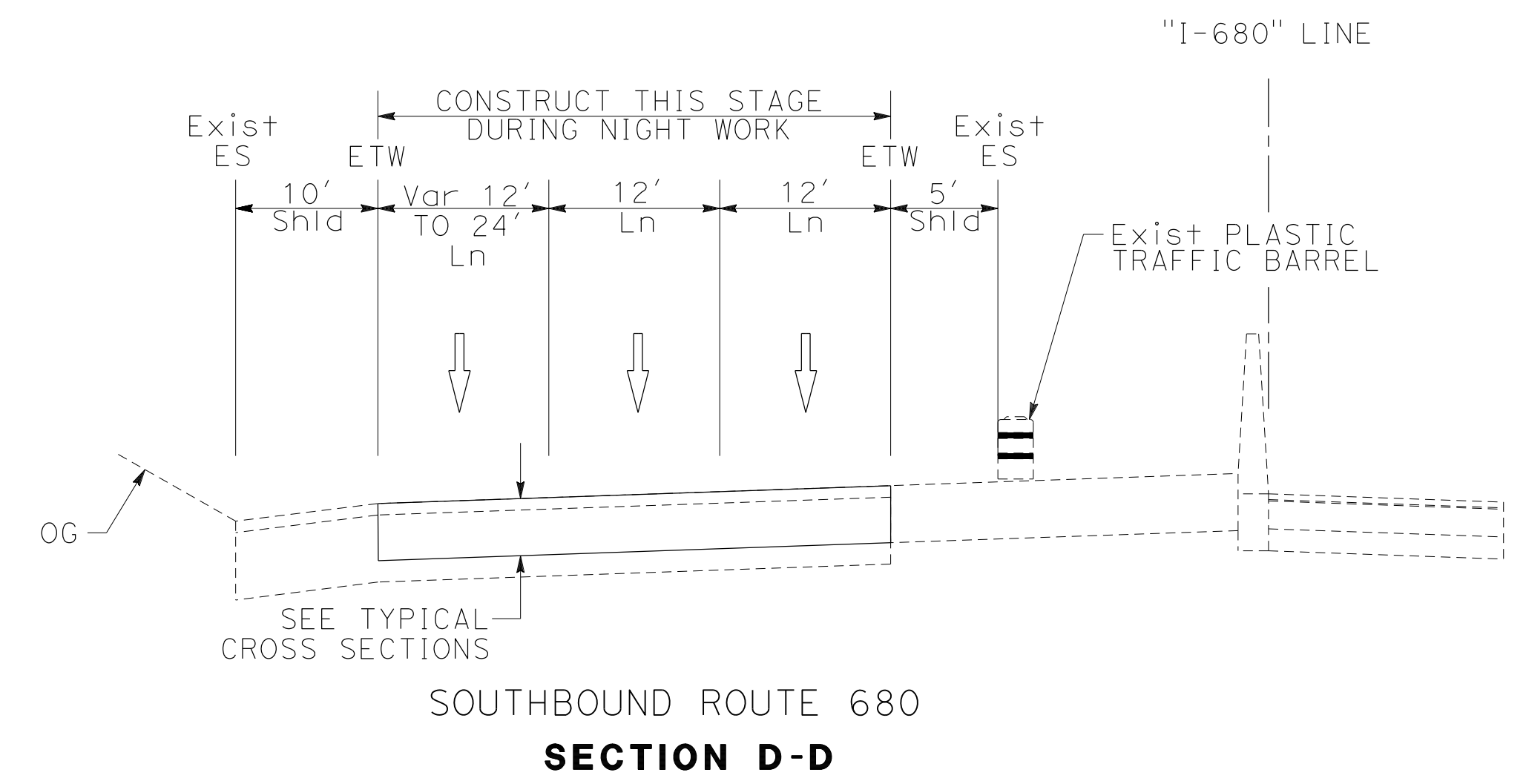
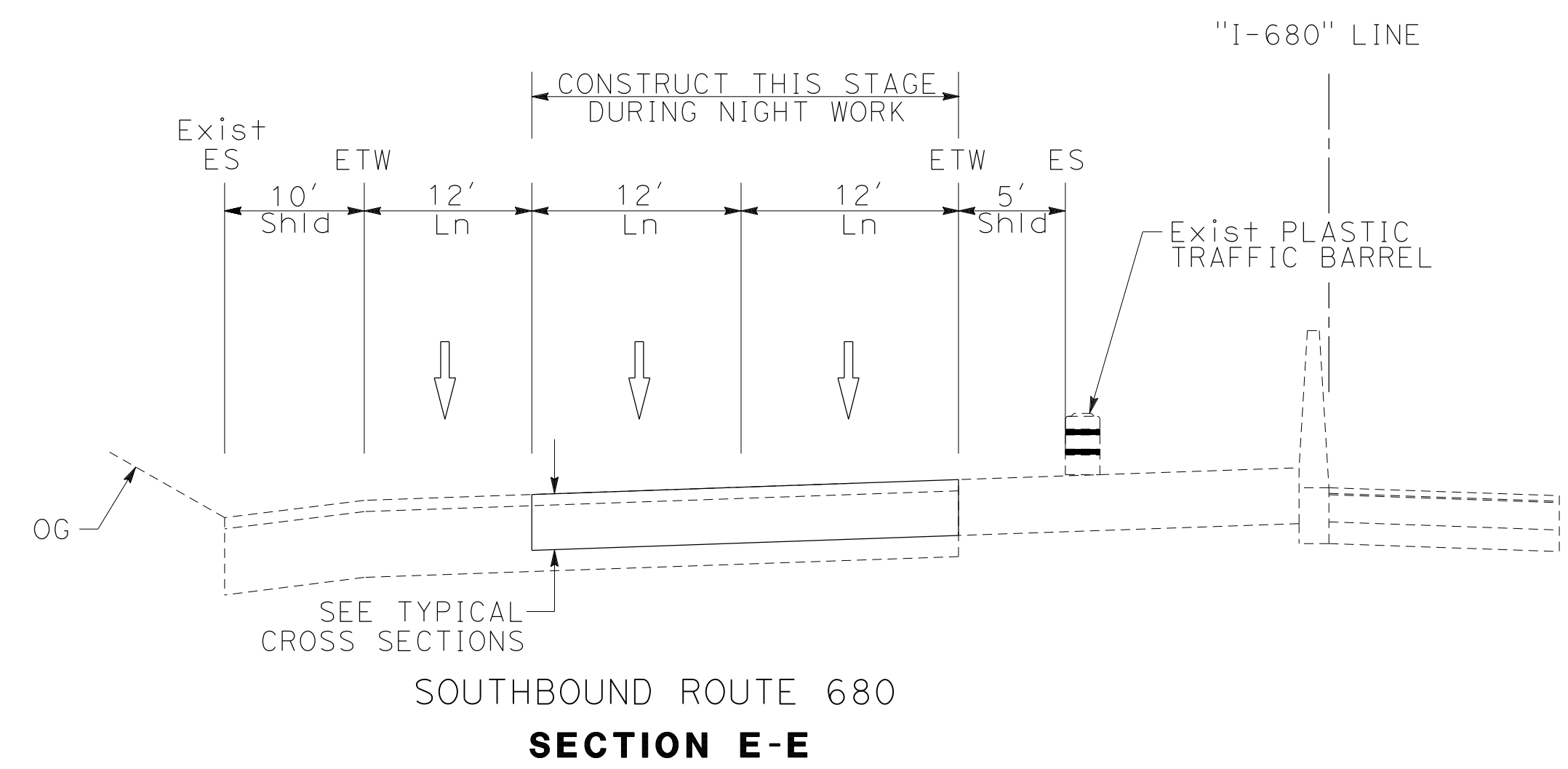
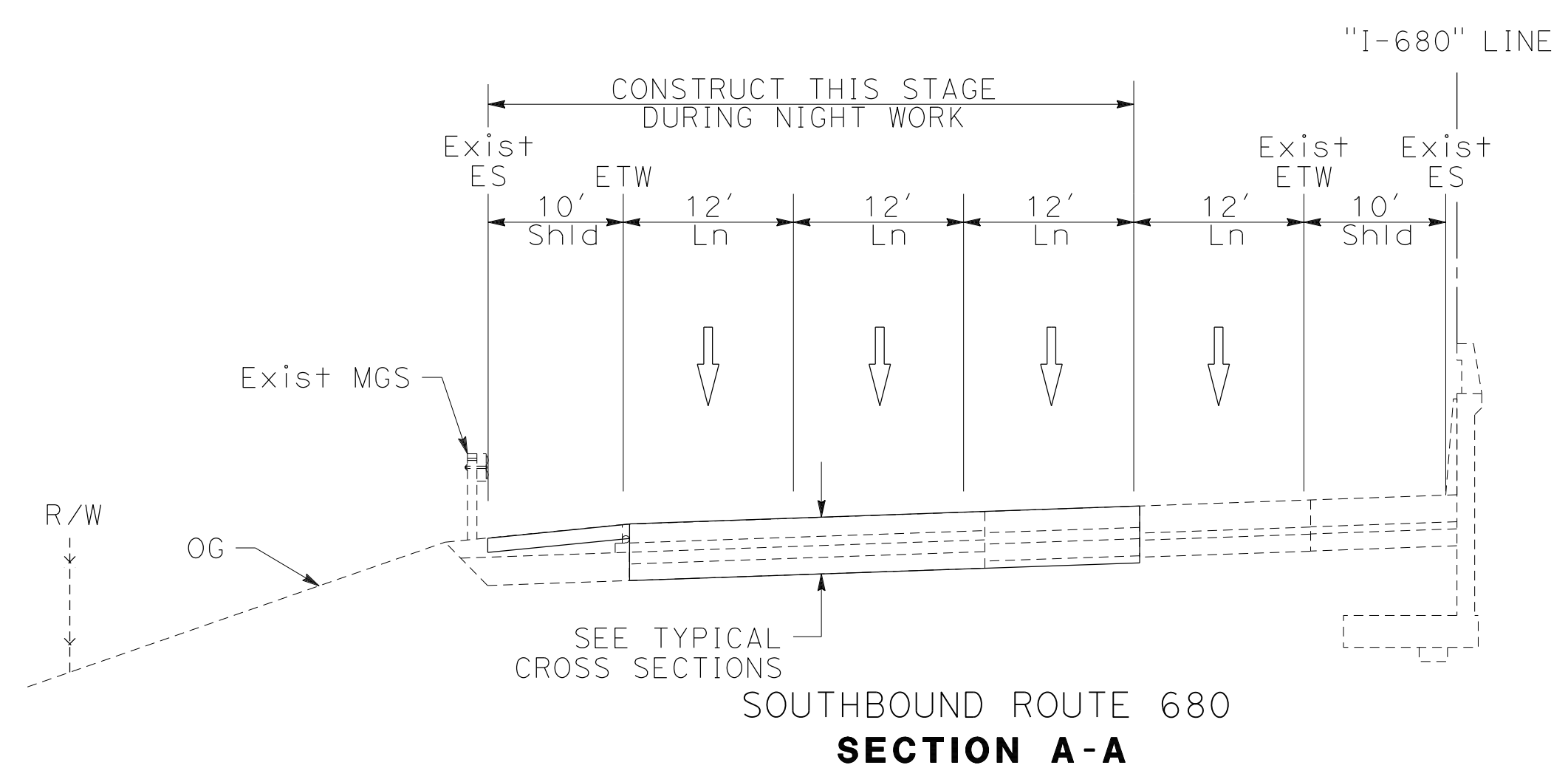
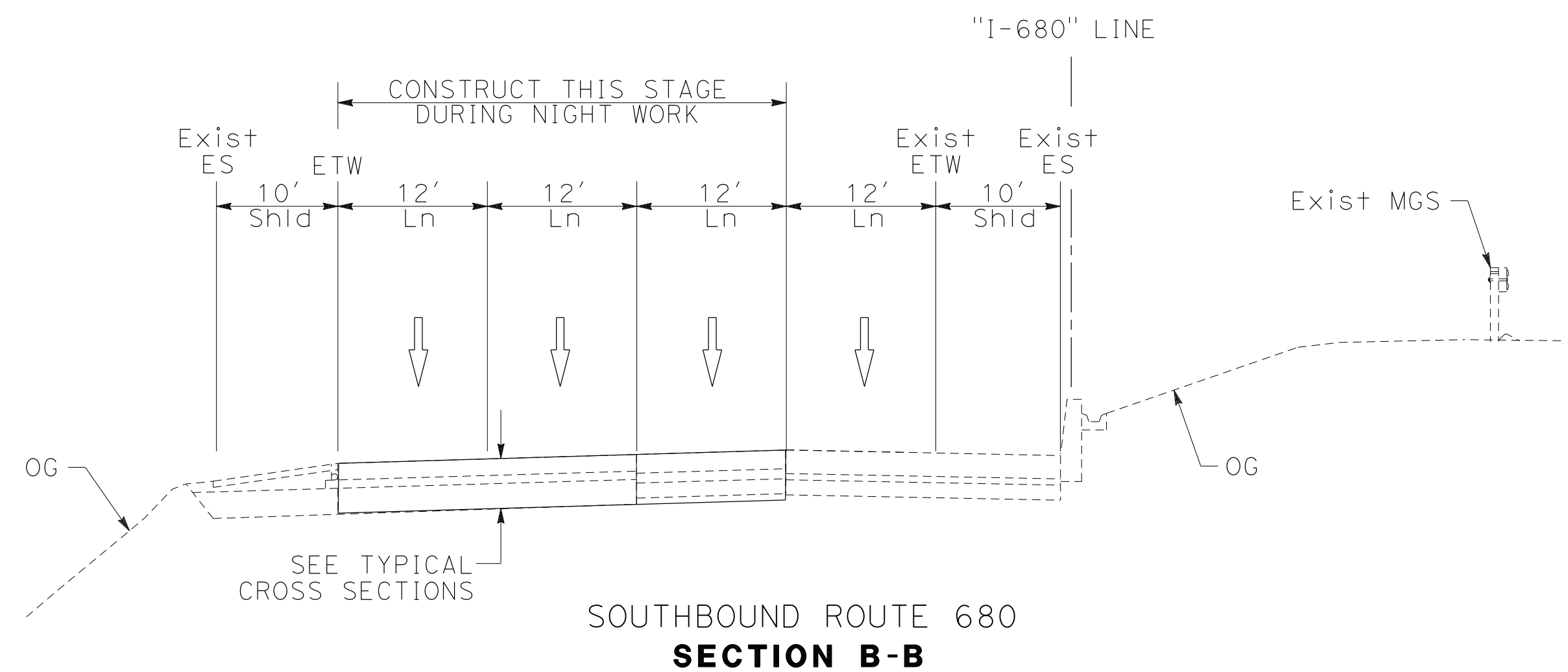
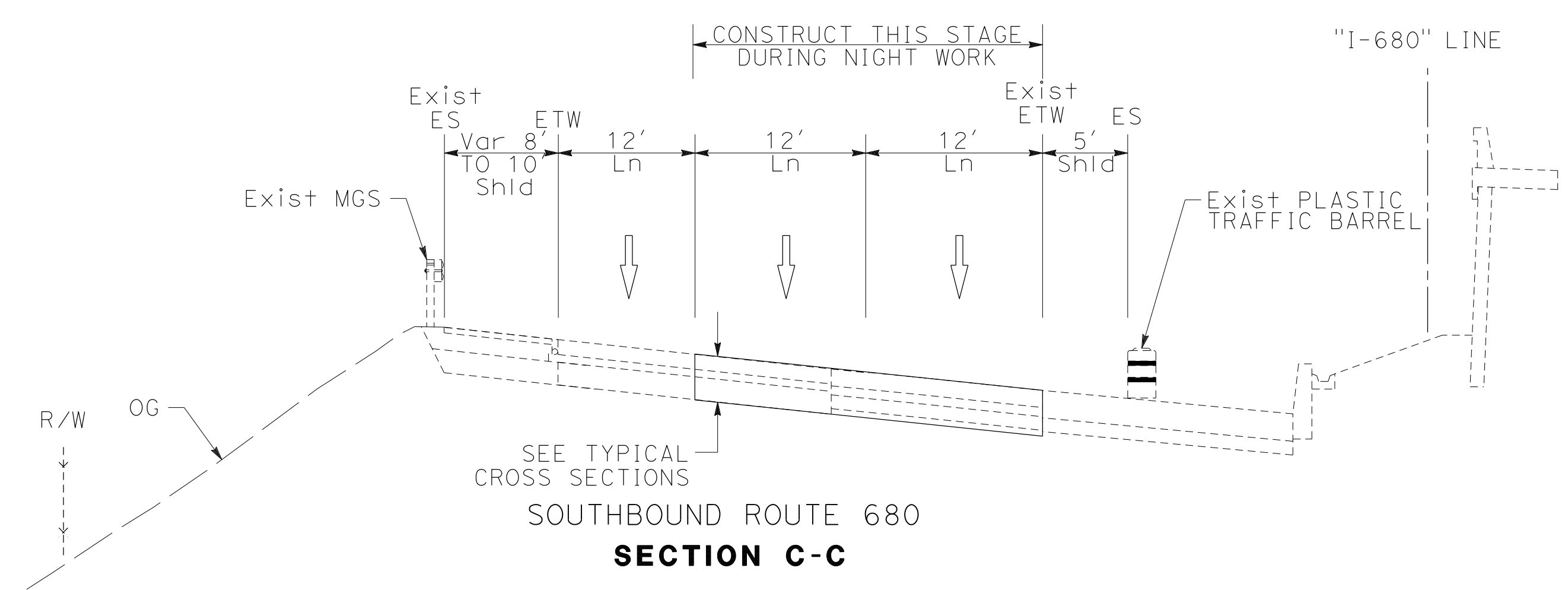

**STAGE CONSTRUCTION AND TRAFFIC HANDLING PLAN**  
**STAGE 3**

NO SCALE

**SC-140**

FOR NOTES, ABBREVIATIONS AND LEGEND, SEE SHEET SC-1 AND SC-144

X:\680\_SB\_GAP\_EXPRESS\000\_CAD\Submittal\CADD\_submittal\0420000235ma140.dgn  
 STATE OF CALIFORNIA - DEPARTMENT OF TRANSPORTATION  
 CONSULTANT: JAMEY VALDIVIA  
 SUPERVISOR: TIMOTHY J. LEE  
 DESIGNED BY: ERIN MCPHERSON  
 CHECKED BY:  
 REVISIONS: 9-29-21

Dist	COUNTY	ROUTE	POST MILES TOTAL PROJECT	SHEET No.	TOTAL SHEETS
04	Ala, CC	680	R11.0/R21.9, R0.0/R0.9	654	1710
			9-29-21 REGISTERED CIVIL ENGINEER DATE		
October 8, 2021 PLANS APPROVAL DATE					
WMH CORPORATION 55 South Market St Suite 1200 San Jose, CA 95113			ALAMEDA CTC 1111 Broadway Suite 800 Oakland, CA 94607		

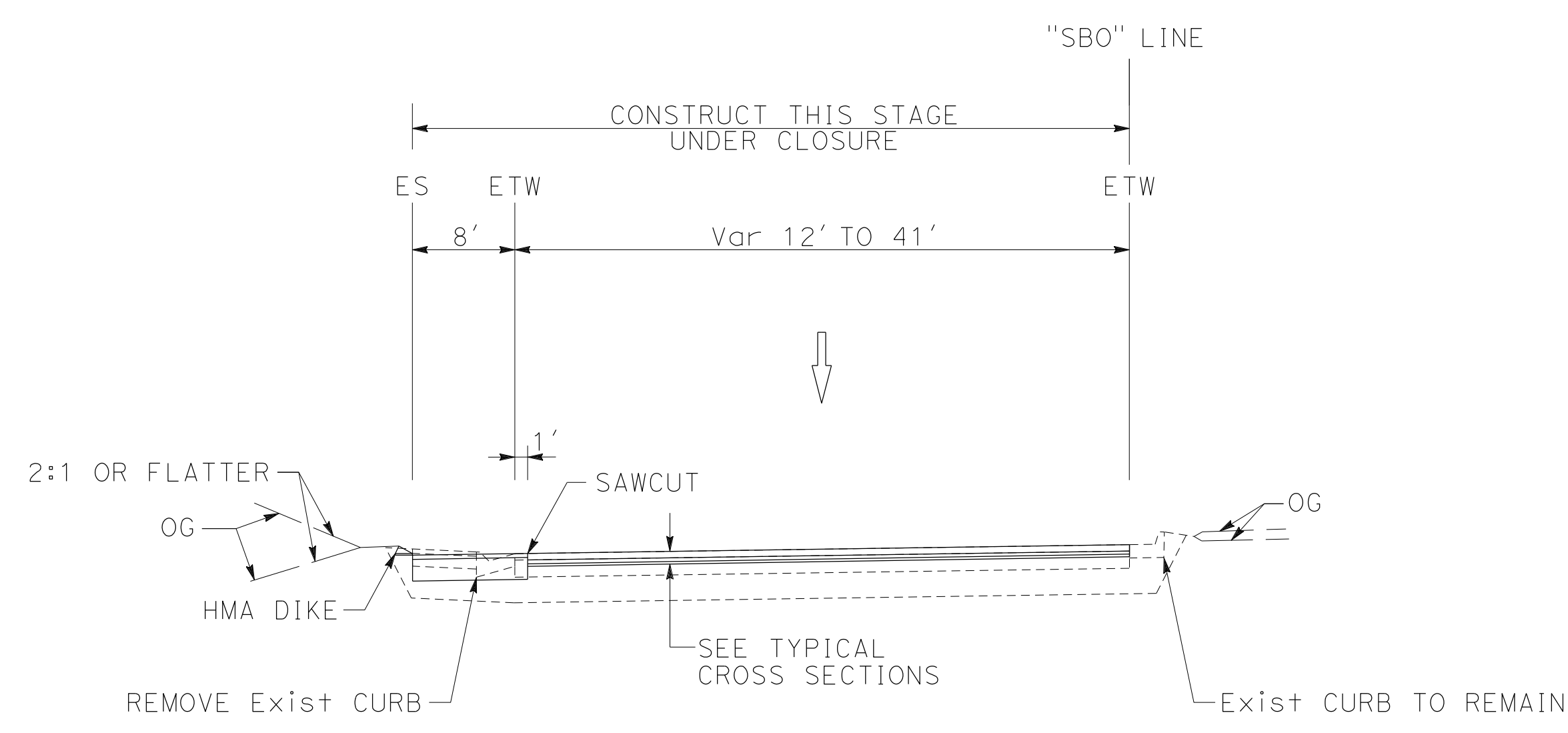

SB ROUTE 680 BERNAL AVE OFF RAMP  
**SECTION H-H**

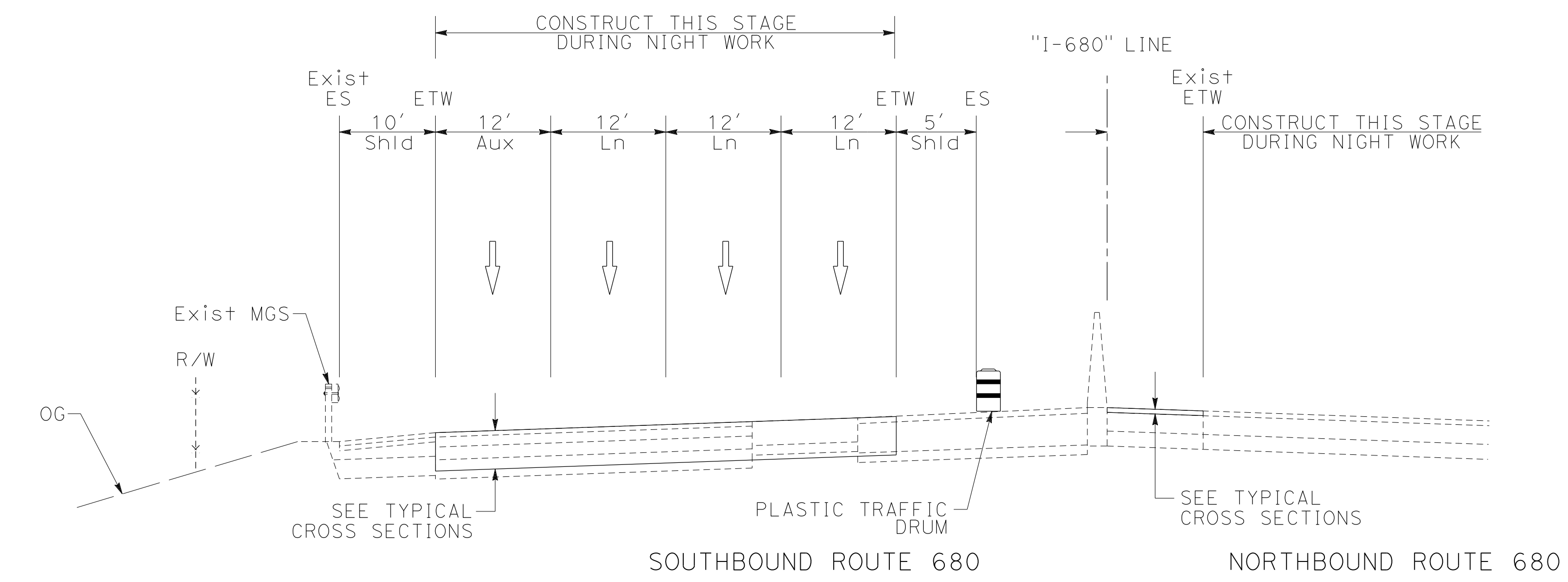

**SECTION J-J**

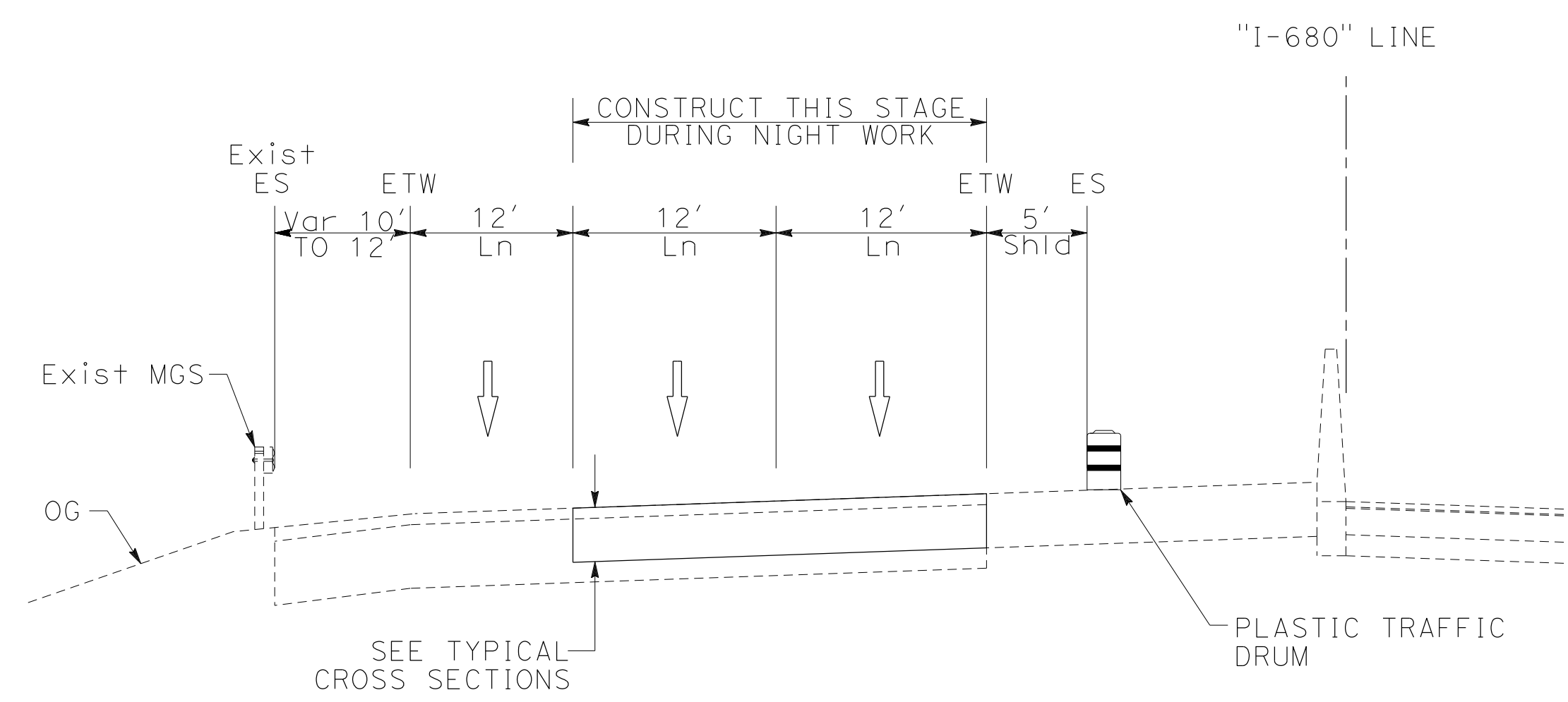

SOUTHBOUND ROUTE 680  
**SECTION G-G**

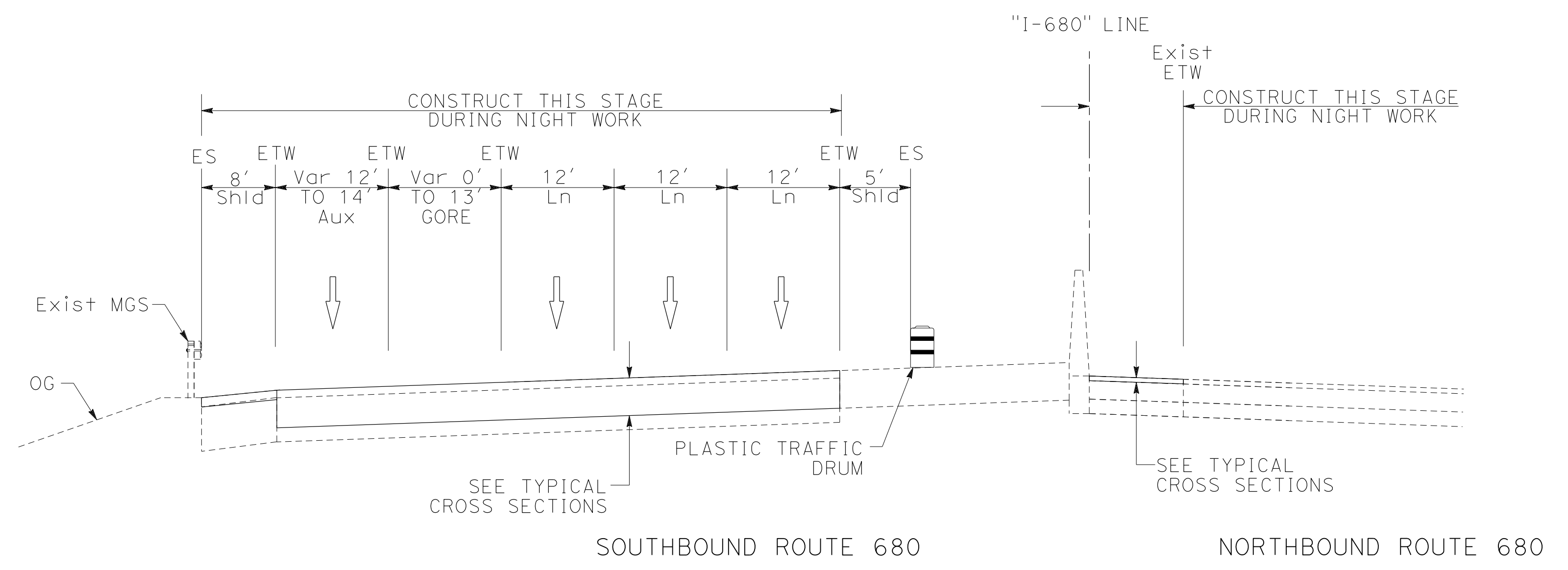

**SECTION I-I**

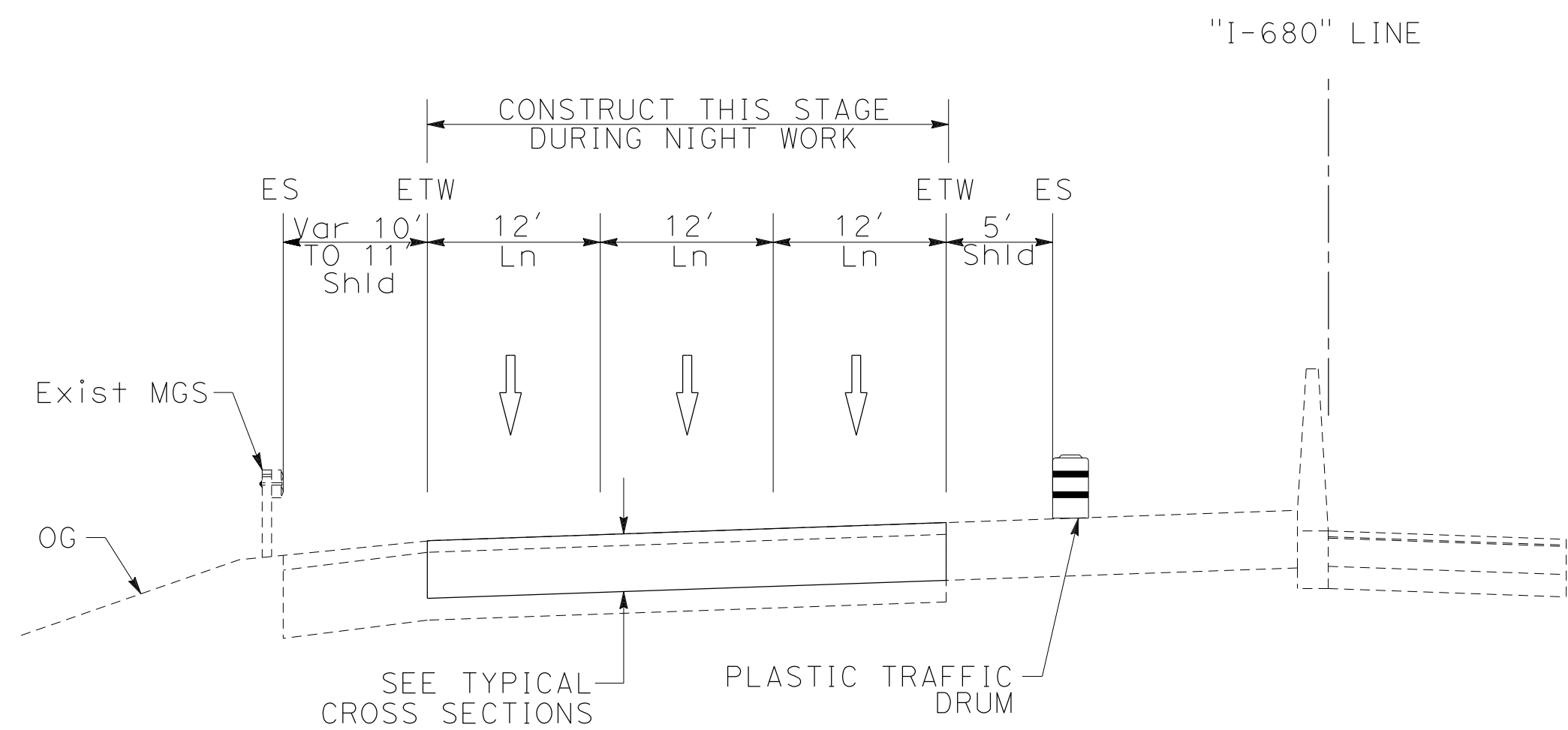

SOUTHBOUND ROUTE 680  
**SECTION F-F**

**STAGE CONSTRUCTION AND TRAFFIC HANDLING PLAN**  
**STAGE 3**

NO SCALE

**SC-141**

FOR NOTES, ABBREVIATIONS AND LEGEND, SEE SHEET SC-1 AND SC-144

X:\680\_SB\_EXPRESS\000\_CAD\Submit\11al\11al\CADD\_sub\11al\11al\0420000235ma141.dgn  
 STATE OF CALIFORNIA - DEPARTMENT OF TRANSPORTATION  
 CONSULTANT: FUNCTIONAL SUPERVISOR: JAMIE VALDIVIA  
 CHECKED BY: ERIN MCPHERSON  
 REVISIONS: REVISED BY: JAMIE VALDIVIA, DATE: 9-29-21  
 CALCULATED/DESIGNED BY: ERIN MCPHERSON  
 SUPERVISOR: TIMOTHY J. LEE

LAST REVISION: 09-29-21      DATE PLOTTED => 3/18/2022      TIME PLOTTED => 4:37:34 PM

Dist	COUNTY	ROUTE	POST MILES TOTAL PROJECT	SHEET No.	TOTAL SHEETS
04	Ala, CC	680	R11.0/R21.9, RO.0/RO.9	655	1710
		REGISTERED CIVIL ENGINEER ERIN D. McPHERSON No. C91111 Exp. 3-31-24 CIVIL STATE OF CALIFORNIA		9-29-21 DATE	
October 8, 2021 PLANS APPROVAL DATE					
WMH CORPORATION 55 South Market St Suite 1200 San Jose, CA 95113			ALAMEDA CTC 1111 Broadway Suite 800 Oakland, CA 94607		

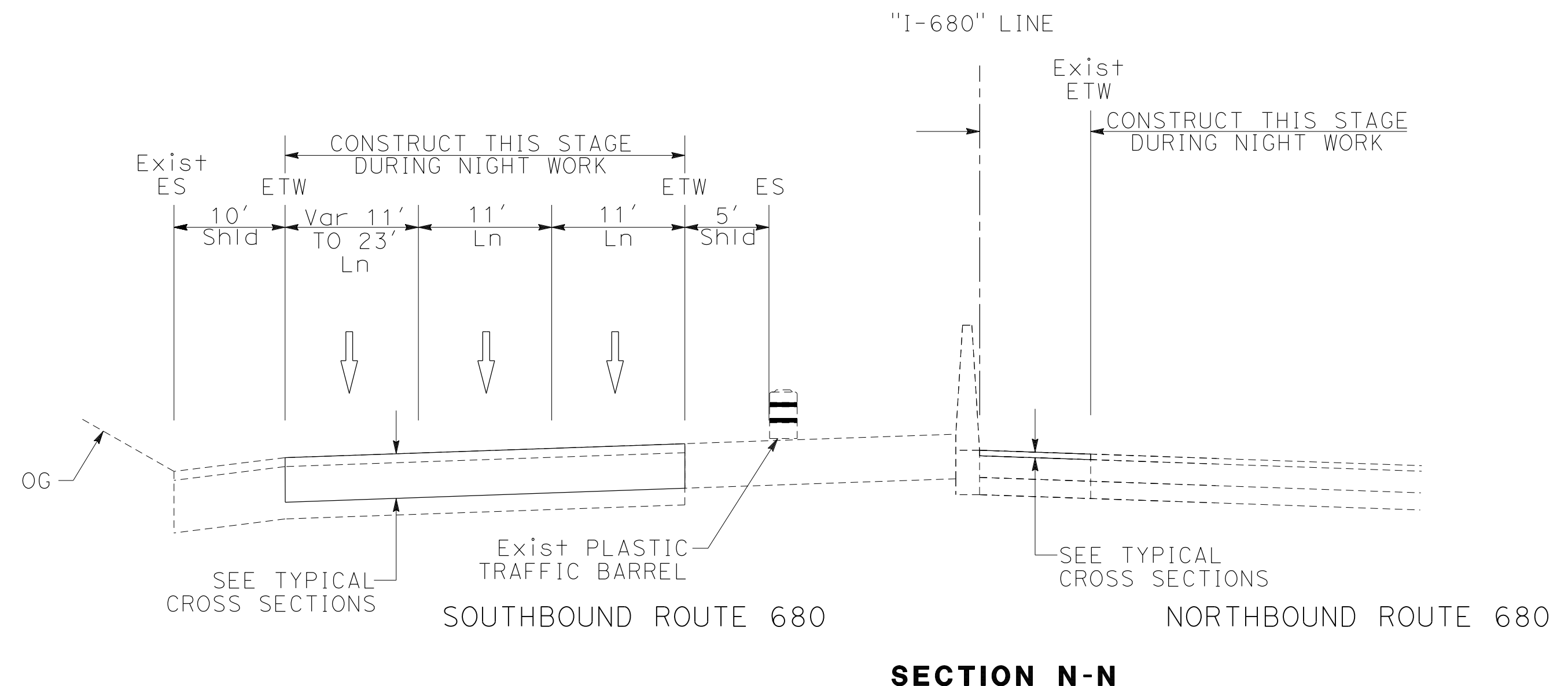
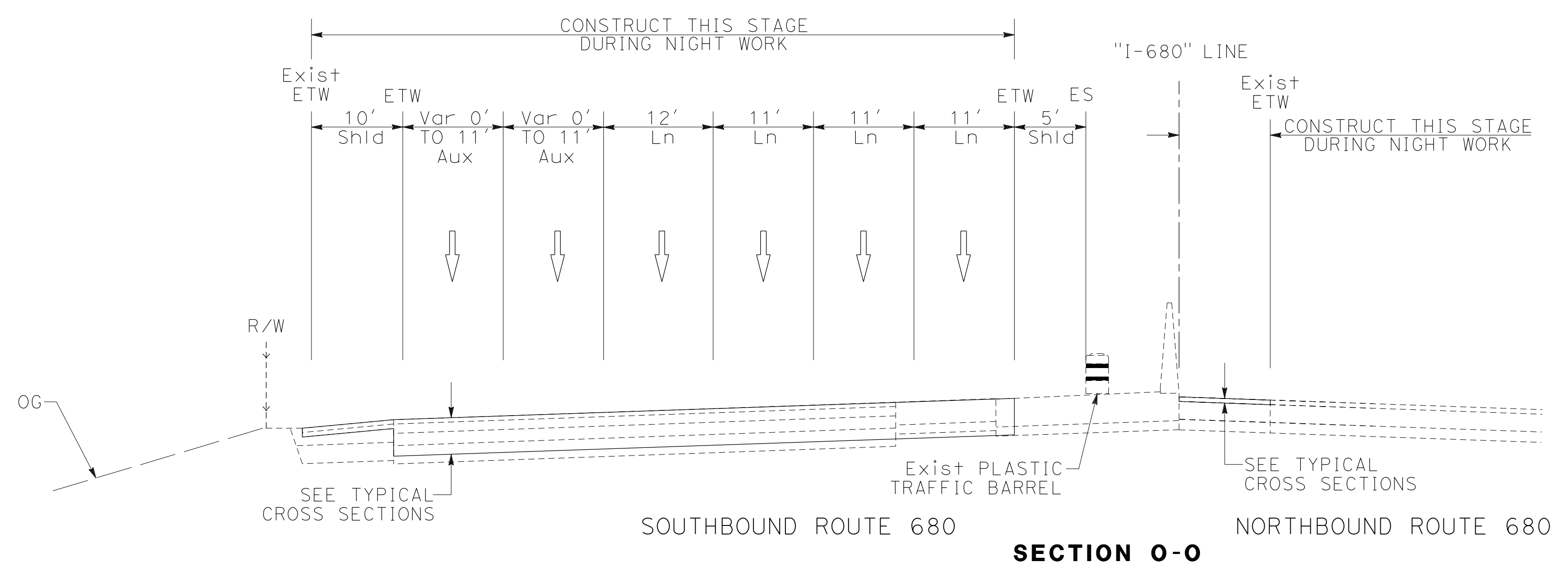
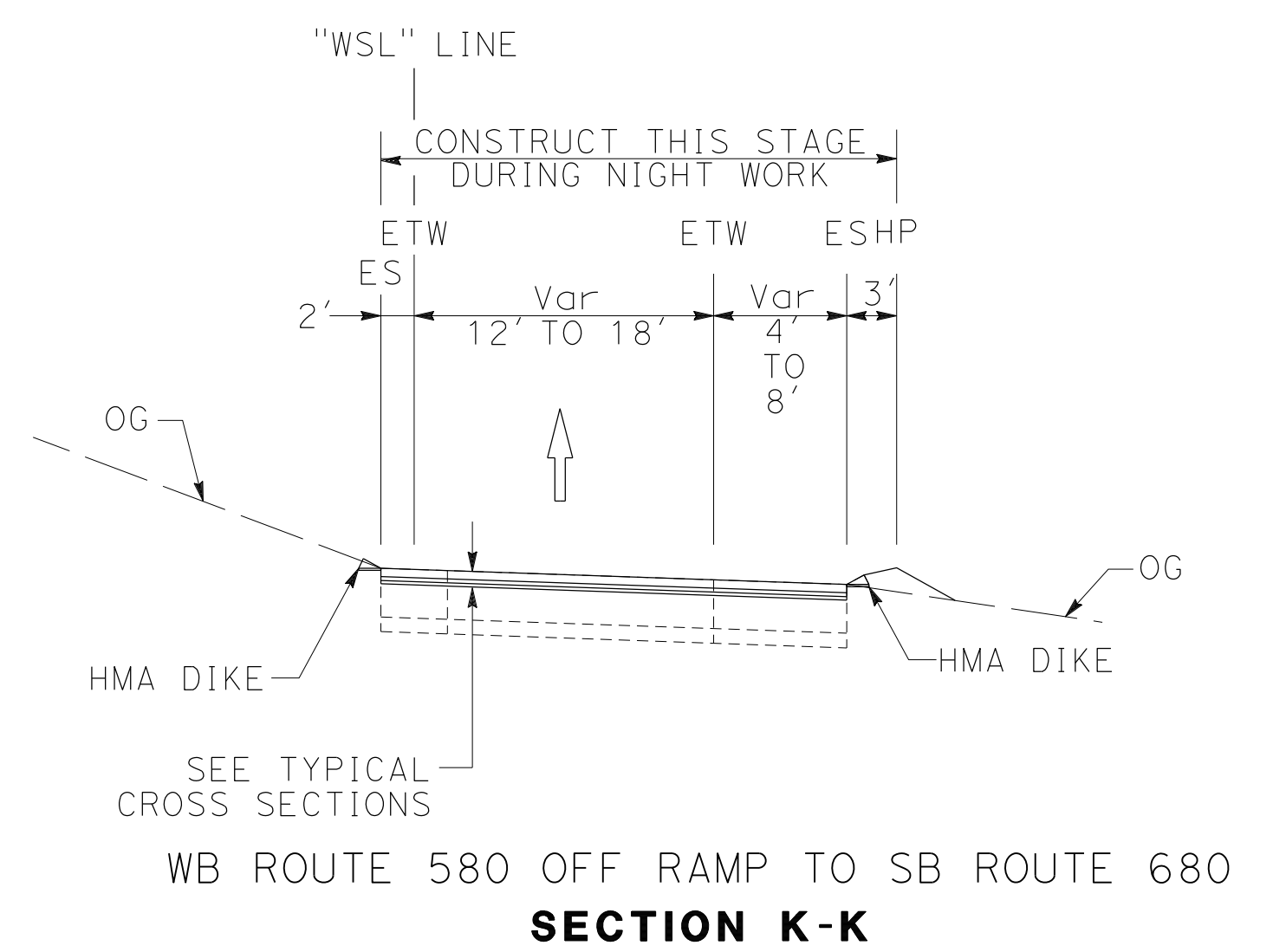
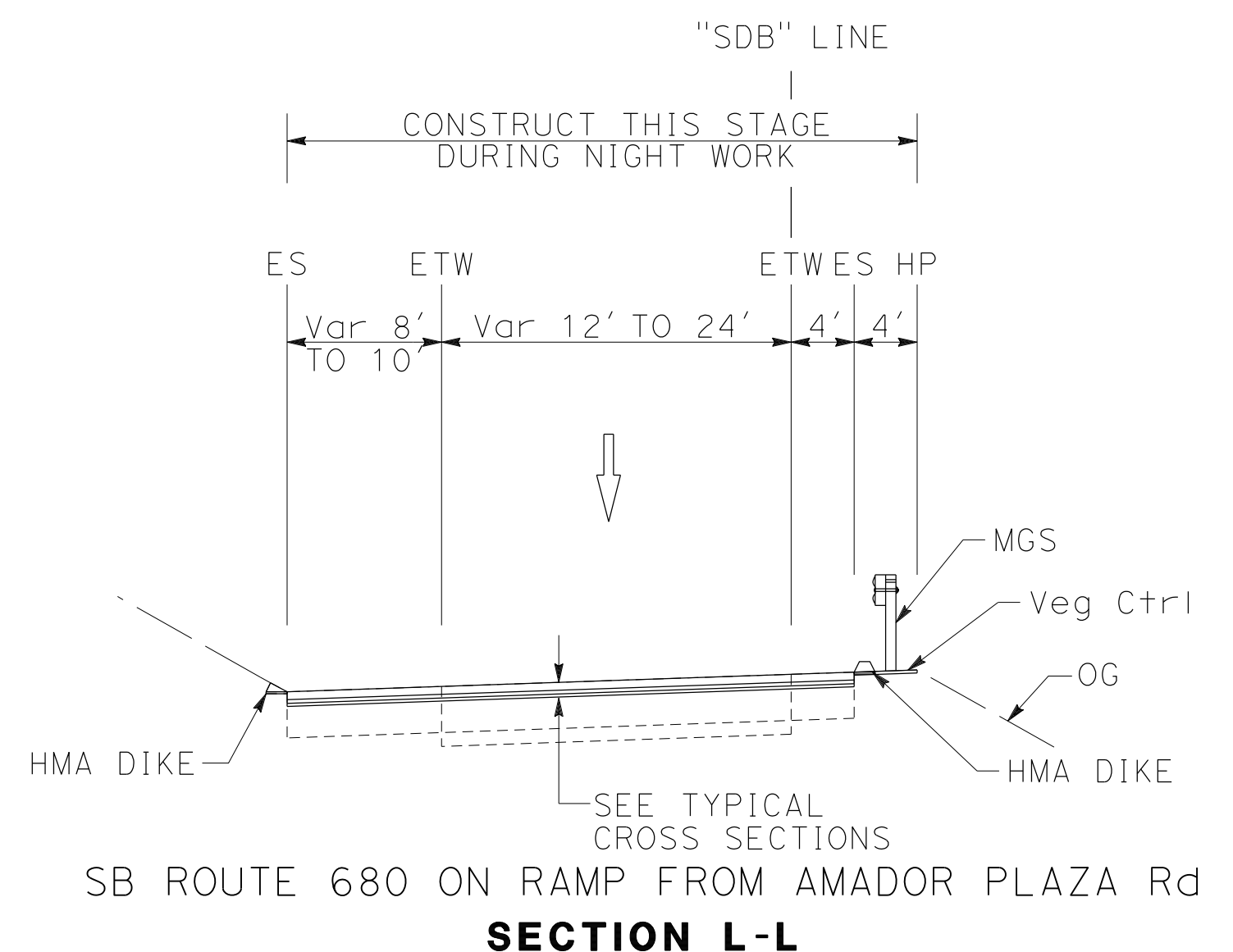
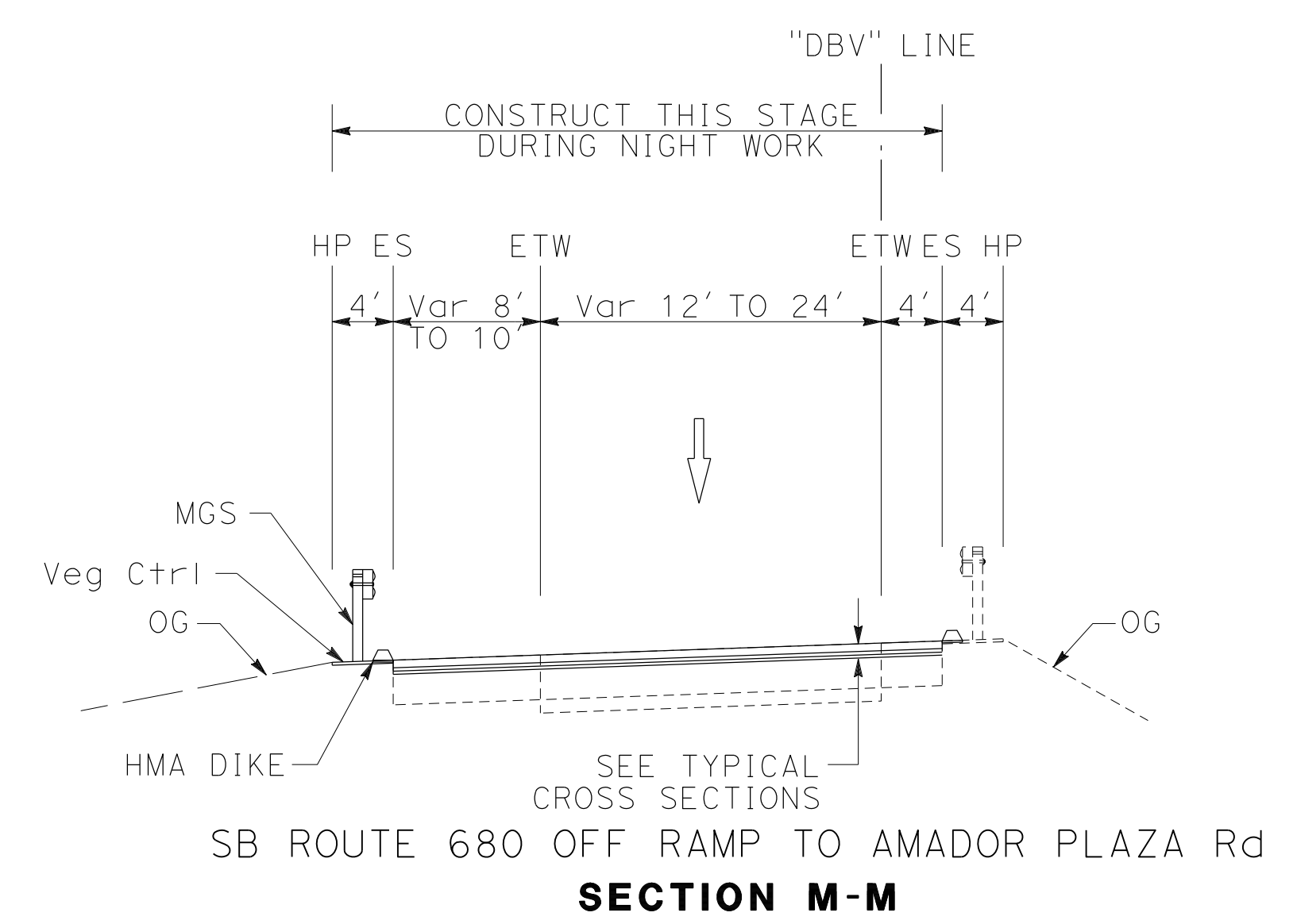

**STAGE CONSTRUCTION AND TRAFFIC HANDLING PLAN**  
**STAGE 3**

NO SCALE

**SC-142**

FOR NOTES, ABBREVIATIONS AND LEGEND, SEE SHEET SC-1 AND SC-144

X:\680\_SB\_EXPRESS\000\_CAD\Submittal\CADD\_submittal\0420000235ma142.dgn  
 STATE OF CALIFORNIA - DEPARTMENT OF TRANSPORTATION  
 CONSULTANT: FUNCTIONAL SUPERVISOR: JAMEY VALDIVIA  
 CHECKED BY: ERIN McPHERSON  
 REVISIONS: 9-29-21  
 DESIGNED BY: ERIN McPHERSON  
 SUPERVISOR: TIMOTHY J. LEE  
 DATE: 9-29-21

LAST REVISION: 09-29-21  
 DATE PLOTTED => 3/18/2022  
 TIME PLOTTED => 4:37:38 PM



Dist	COUNTY	ROUTE	POST MILES TOTAL PROJECT	SHEET No.	TOTAL SHEETS
04	Ala, CC	680	R11.0/R21.9, RO.0/RO.9	657	1710

REGISTERED CIVIL ENGINEER	DATE
<i>Erin D. McPherson</i>	9-29-21
October 8, 2021	
PLANS APPROVAL DATE	

ERIN D. McPHERSON No. C91111 Exp. 3-31-24 CIVIL STATE OF CALIFORNIA	THE STATE OF CALIFORNIA OR ITS OFFICERS OR AGENTS SHALL NOT BE RESPONSIBLE FOR THE ACCURACY OR COMPLETENESS OF SCANNED COPIES OF THIS PLAN SHEET.
WMH CORPORATION 55 South Market St Suite 1200 San Jose, CA 95113	ALAMEDA CTC 1111 Broadway Suite 800 Oakland, CA 94607

**NOTES:**

1. FOR ACCURATE RIGHT OF WAY DATA, CONTACT RIGHT OF WAY ENGINEERING AT THE DISTRICT OFFICE.
2. FOR GORE DETAILS AND PAVEMENT ELEVATIONS, SEE CONSTRUCTION DETAILS.
3. INTERIOR REHABILITATION SHOWN IN STAGE 3 FROM APPROX. STA "I-680" 162+00 TO 330+00 AND STA "I-680" 540+00 TO 685+00 CAN BE DONE CONCURRENTLY WITH STAGE 2 WORK.
4. NEWLY CONSTRUCTED INTERIOR LANE MAY BE USED DURING NIGHTTIME MAINLINE REHABILITATION WORK. MAINTAIN CLOSURE OF NEWLY CONSTRUCTED EXPRESS LANE FOR DAYTIME OPERATIONS.

**STAGE 3 CONSTRUCTION:**

- 1 CONSTRUCT REHABILITATION DURING NIGHT WORK.
- 2 COMPLETE RAMP CLOSURE.
- 3 CONSTRUCT MGS.
- 4 CONSTRUCT RAMP WIDENING.

**STAGE 3 TRAFFIC:**

- MAINTAIN AT LEAST 1 LANE OF TRAFFIC ON SB 680 DURING NIGHT WORK. SEE SPECIAL PROVISIONS FOR THE LANE CLOSURES.
- CLOSE RAMPS DURING NIGHT HOURS TO ALLOW FOR GRIND AND OVERLAY OPERATIONS. SEE SPECIAL PROVISIONS FOR LANE CLOSURE CHARTS

**STAGE 3 DRAINAGE:**

- CONSTRUCT DS **D7**
- CONSTRUCT DS **157** a

DESIGNED BY	JV
DATE	9-29-21
REVISOR	ERIN MCPHERSON
CHECKED BY	ERIN MCPHERSON
FUNCTIONAL SUPERVISOR	TIMOTHY J. LEE
CONSULTANT	W.M.H. CORPORATION
DEPARTMENT	TRANSPORTATION
PROJECT	STATE OF CALIFORNIA - DEPARTMENT OF TRANSPORTATION

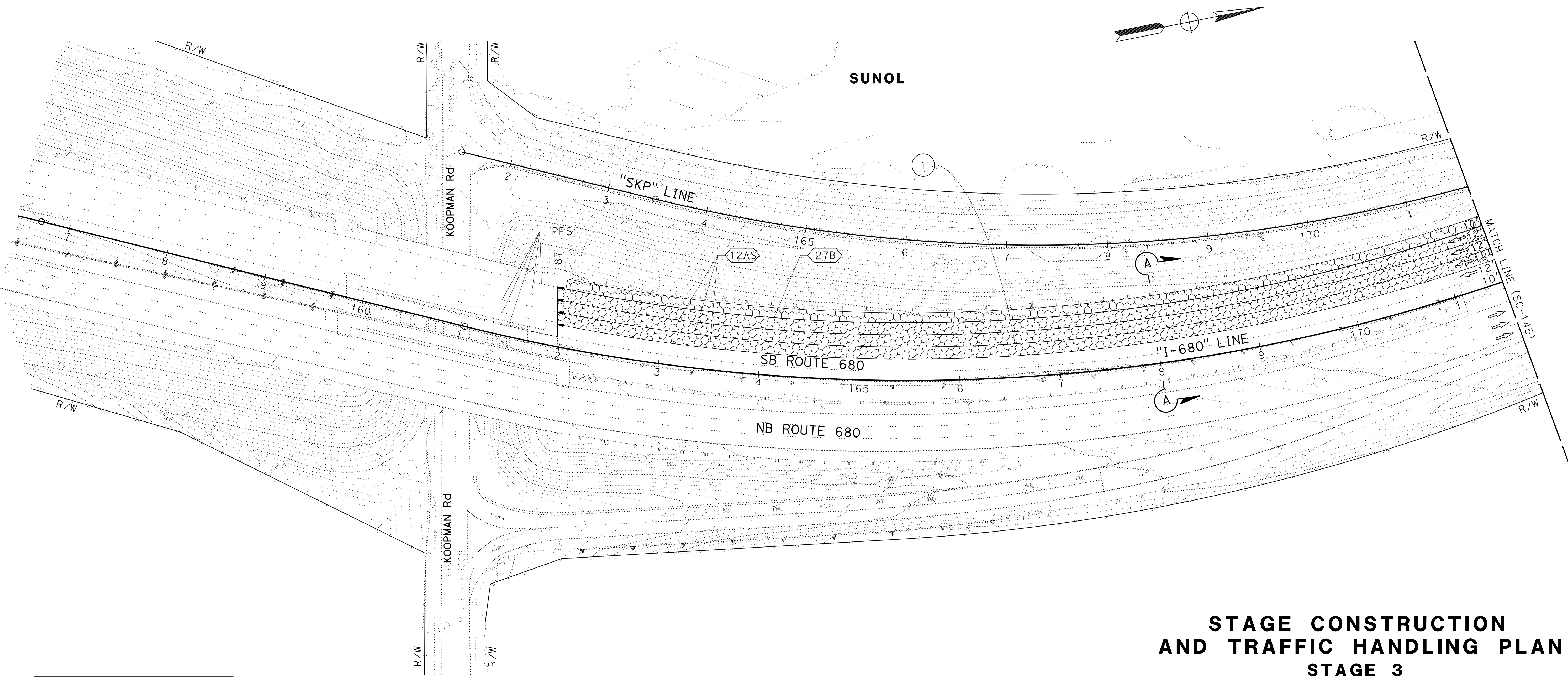

FOR NOTES, ABBREVIATIONS AND LEGEND, SEE SHEET SC-1

APPROVED FOR STAGE CONSTRUCTION AND TRAFFIC HANDLING WORK ONLY

**STAGE CONSTRUCTION AND TRAFFIC HANDLING PLAN**  
**STAGE 3**

SCALE: 1" = 50'

**SC-144**

LAST REVISION: 09-29-21 DATE PLOTTED => 8-MAR-2022 TIME PLOTTED => 10:09

Dist	COUNTY	ROUTE	POST MILES TOTAL PROJECT	SHEET No.	TOTAL SHEETS
04	Ala, CC	680	R11.0/R21.9, R0.0/R0.9	658	1710
			9-29-21		
REGISTERED CIVIL ENGINEER			DATE		
			October 8, 2021		
			PLANS APPROVAL DATE		
<small>THE STATE OF CALIFORNIA OR ITS OFFICERS OR AGENTS SHALL NOT BE RESPONSIBLE FOR THE ACCURACY OR COMPLETENESS OF SCANNED COPIES OF THIS PLAN SHEET.</small>					
WMH CORPORATION 55 South Market St Suite 1200 San Jose, CA 95113			ALAMEDA CTC 1111 Broadway Suite 800 Oakland, CA 94607		

NOTE:  
 FOR ACCURATE RIGHT OF WAY DATA, CONTACT  
 RIGHT OF WAY ENGINEERING AT THE DISTRICT OFFICE.

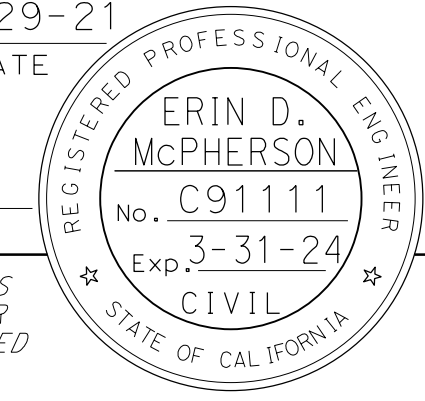
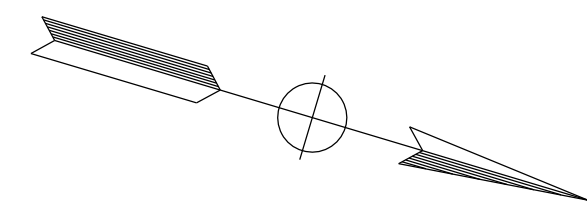

CALCULATED-DESIGNED BY	JAMIEY VALDIVIA
CHECKED BY	ERIN MCPHERSON
REVISIONED BY	JV
DATE REVISION	9-29-21
CONSULTANT FUNCTIONAL SUPERVISOR	TIMOTHY J. LEE
DEPARTMENT OF TRANSPORTATION	STATE OF CALIFORNIA

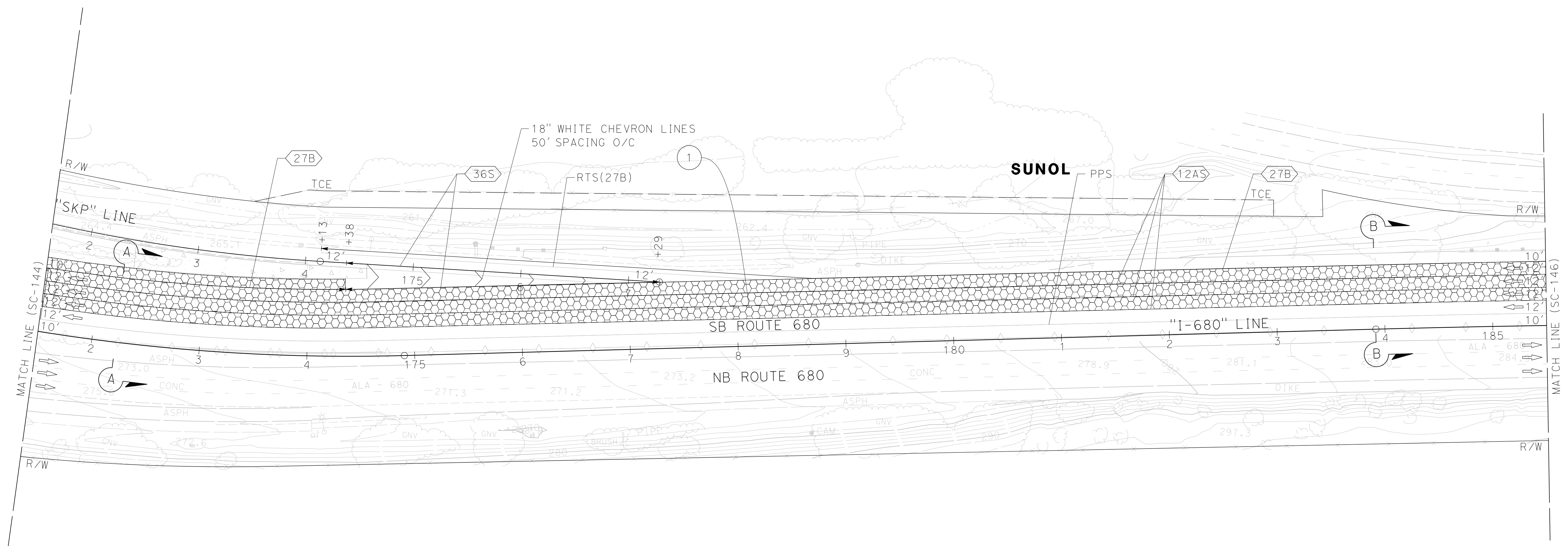

FOR NOTES, ABBREVIATIONS AND  
 LEGEND, SEE SHEET SC-1 AND SC-144

APPROVED FOR STAGE CONSTRUCTION AND TRAFFIC HANDLING WORK ONLY

## STAGE CONSTRUCTION AND TRAFFIC HANDLING PLAN STAGE 3

SCALE: 1" = 50'

**SC-145**

LAST REVISION      DATE PLOTTED => 3/21/2022      09-29-21      TIME PLOTTED => 4:08:24 PM

Dist	COUNTY	ROUTE	POST MILES TOTAL PROJECT	SHEET No.	TOTAL SHEETS
04	Ala, CC	680	R11.0/R21.9, R0.0/R0.9	659	1710

<i>Erin D. McPherson</i> REGISTERED CIVIL ENGINEER	9-29-21 DATE
October 8, 2021 PLANS APPROVAL DATE	

  

ERIN D. McPHERSON No. C91111 Exp. 3-31-24 CIVIL STATE OF CALIFORNIA	THE STATE OF CALIFORNIA OR ITS OFFICERS OR AGENTS SHALL NOT BE RESPONSIBLE FOR THE ACCURACY OR COMPLETENESS OF SCANNED COPIES OF THIS PLAN SHEET.
WMH CORPORATION 55 South Market St Suite 1200 San Jose, CA 95113	ALAMEDA CTC 1111 Broadway Suite 800 Oakland, CA 94607

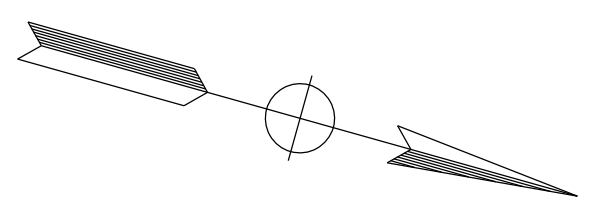

NOTE:  
FOR ACCURATE RIGHT OF WAY DATA, CONTACT  
RIGHT OF WAY ENGINEERING AT THE DISTRICT OFFICE.

DESIGNED BY	JAMEY VALDIVIA
CHECKED BY	ERIN MCPHERSON
REVISIONED BY	JV
DATE REVISIONED	9-29-21
FUNCTIONAL SUPERVISOR	TIMOTHY J. LEE
CONSULTANT	DEPARTMENT OF TRANSPORTATION
STATE OF CALIFORNIA	DEPARTMENT OF TRANSPORTATION

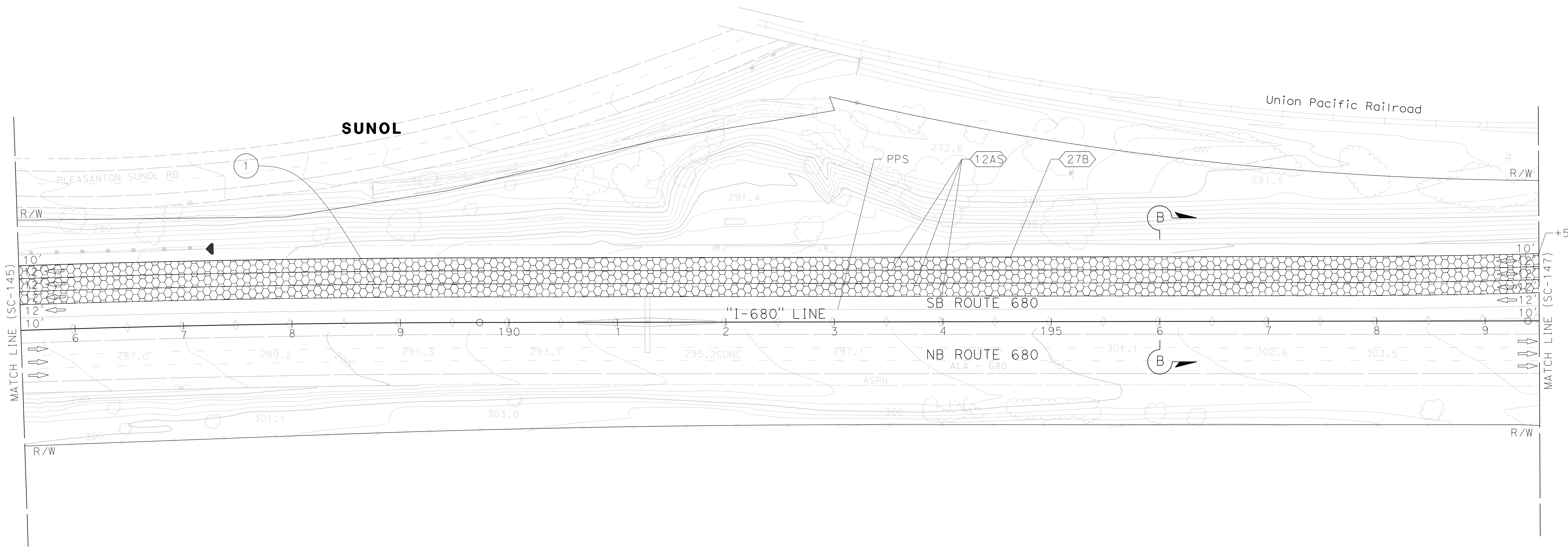

FOR NOTES, ABBREVIATIONS AND  
LEGEND, SEE SHEET SC-1 AND SC-144

APPROVED FOR STAGE CONSTRUCTION AND TRAFFIC HANDLING WORK ONLY

**STAGE CONSTRUCTION  
AND TRAFFIC HANDLING PLAN  
STAGE 3**

SCALE: 1" = 50'

**SC-146**

LAST REVISION DATE PLOTTED => 3/21/2022 09-29-21 TIME PLOTTED => 4:08:29 PM

Dist	COUNTY	ROUTE	POST MILES TOTAL PROJECT	SHEET No.	TOTAL SHEETS
04	Ala, CC	680	R11.0/R21.9, R0.0/R0.9	660	1710

  

<i>Erin D. McPherson</i>		9-29-21
REGISTERED CIVIL ENGINEER	DATE	
October 8, 2021		
PLANS APPROVAL DATE		

THE STATE OF CALIFORNIA OR ITS OFFICERS OR AGENTS SHALL NOT BE RESPONSIBLE FOR THE ACCURACY OR COMPLETENESS OF SCANNED COPIES OF THIS PLAN SHEET.	
WMH CORPORATION 55 South Market St Suite 1200 San Jose, CA 95113	ALAMEDA CTC 1111 Broadway Suite 800 Oakland, CA 94607

NOTE:  
FOR ACCURATE RIGHT OF WAY DATA, CONTACT  
RIGHT OF WAY ENGINEERING AT THE DISTRICT OFFICE.

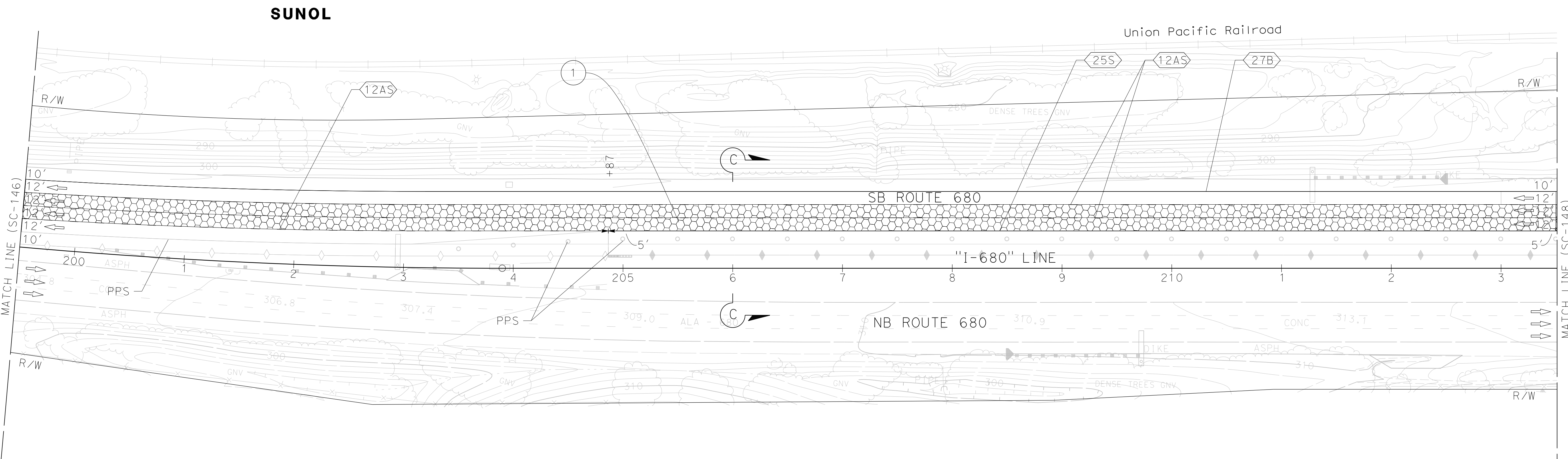
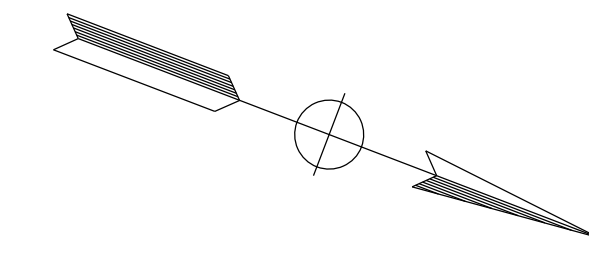

**SUNOL**

**STAGE CONSTRUCTION  
AND TRAFFIC HANDLING PLAN  
STAGE 3**

SCALE: 1" = 50'

**SC-147**

APPROVED FOR STAGE CONSTRUCTION AND TRAFFIC HANDLING WORK ONLY

FOR NOTES, ABBREVIATIONS AND  
LEGEND, SEE SHEET SC-1 AND SC-144

CALCULATED- DESIGNED BY	CHECKED BY	CONSULTANT FUNCTIONAL SUPERVISOR	JV
JAMEY VALDIVIA	ERIN MCPHERSON	TIMOTHY J. LEE	9-29-21

LAST REVISION    DATE PLOTTED => 3/21/2022    09-29-21    TIME PLOTTED => 4:08:33 PM

NOTE:  
 FOR ACCURATE RIGHT OF WAY DATA, CONTACT  
 RIGHT OF WAY ENGINEERING AT THE DISTRICT OFFICE.

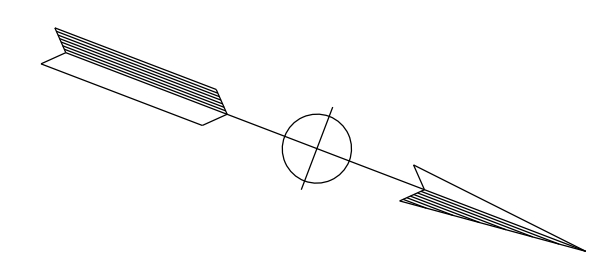

Dist	COUNTY	ROUTE	POST MILES TOTAL PROJECT	SHEET No.	TOTAL SHEETS
04	Ala, CC	680	R11.0/R21.9, R0.0/R0.9	661	1710

<i>Erin D. McPherson</i>		9-29-21
REGISTERED CIVIL ENGINEER	DATE	
October 8, 2021		
PLANS APPROVAL DATE		

ERIN D. McPHERSON No. C91111 Exp. 3-31-24 CIVIL STATE OF CALIFORNIA	
---------------------------------------------------------------------------------	--

WMH CORPORATION 55 South Market St Suite 1200 San Jose, CA 95113	ALAMEDA CTC 1111 Broadway Suite 800 Oakland, CA 94607
---------------------------------------------------------------------------	----------------------------------------------------------------

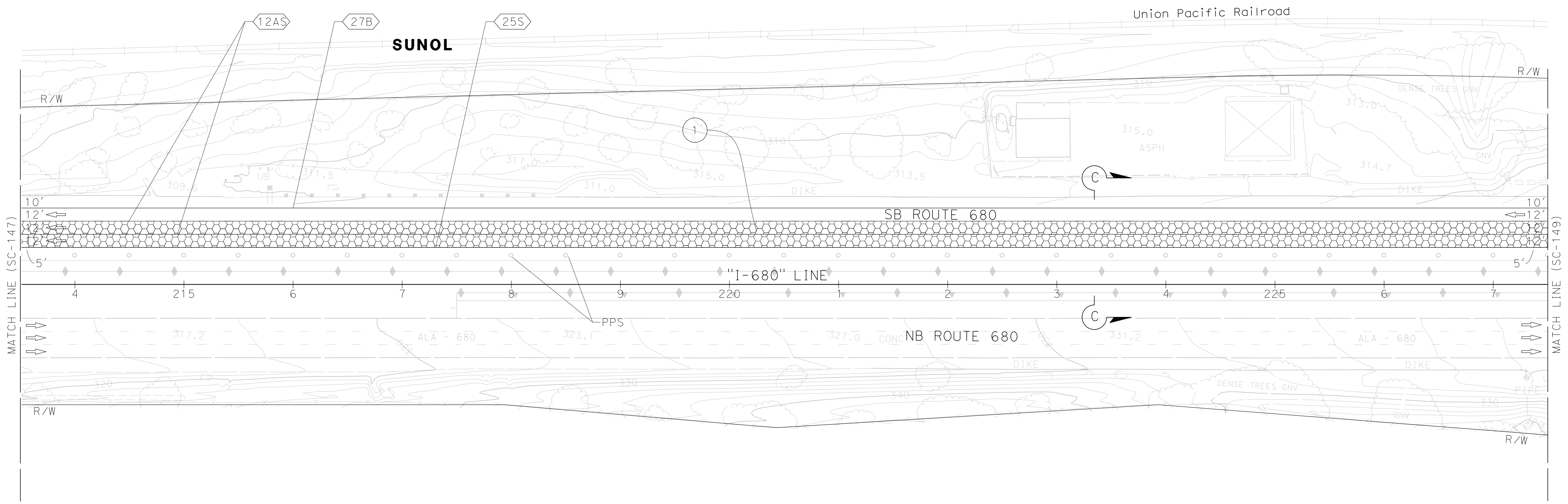

## STAGE CONSTRUCTION AND TRAFFIC HANDLING PLAN STAGE 3

SCALE: 1" = 50'

**SC-148**

FOR NOTES, ABBREVIATIONS AND  
LEGEND, SEE SHEET SC-1 AND SC-144

APPROVED FOR STAGE CONSTRUCTION AND TRAFFIC HANDLING WORK ONLY

X:\680\_SB\_EXPRESS\000\_CAD\Submit\148\148.dgn  
 STATE OF CALIFORNIA - DEPARTMENT OF TRANSPORTATION  
 CONSULTANT FUNCTIONAL SUPERVISOR  
 JAMEY VALDIVIA  
 ERIN McPHERSON  
 TIMOTHY J. LEE  
 CHECKED BY  
 REVISOR  
 DATE  
 9-29-21  
 JV

Dist	COUNTY	ROUTE	POST MILES TOTAL PROJECT	SHEET No.	TOTAL SHEETS
04	Ala, CC	680	R11.0/R21.9, R0.0/R0.9	662	1710
			9-29-21		
REGISTERED CIVIL ENGINEER			DATE		
October 8, 2021			PLANS APPROVAL DATE		
<small>THE STATE OF CALIFORNIA OR ITS OFFICERS OR AGENTS SHALL NOT BE RESPONSIBLE FOR THE ACCURACY OR COMPLETENESS OF SCANNED COPIES OF THIS PLAN SHEET.</small>					
WMH CORPORATION 55 South Market St Suite 1200 San Jose, CA 95113			ALAMEDA CTC 1111 Broadway Suite 800 Oakland, CA 94607		

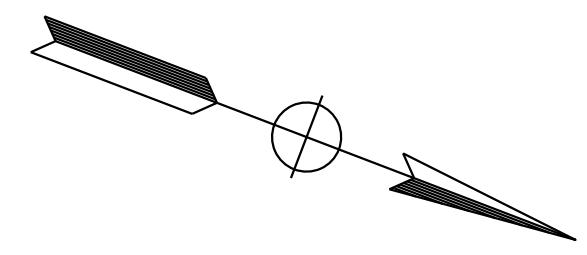

NOTE:  
FOR ACCURATE RIGHT OF WAY DATA, CONTACT  
RIGHT OF WAY ENGINEERING AT THE DISTRICT OFFICE.

REVISOR	DATE	REVISION
JV	9-29-21	
CALCULATED/DESIGNED BY: JAMEY VALDIVIA CHECKED BY: ERIN MCPHERSON CONSULTANT SUPERVISOR: TIMOTHY J. LEE		
STATE OF CALIFORNIA - DEPARTMENT OF TRANSPORTATION 		

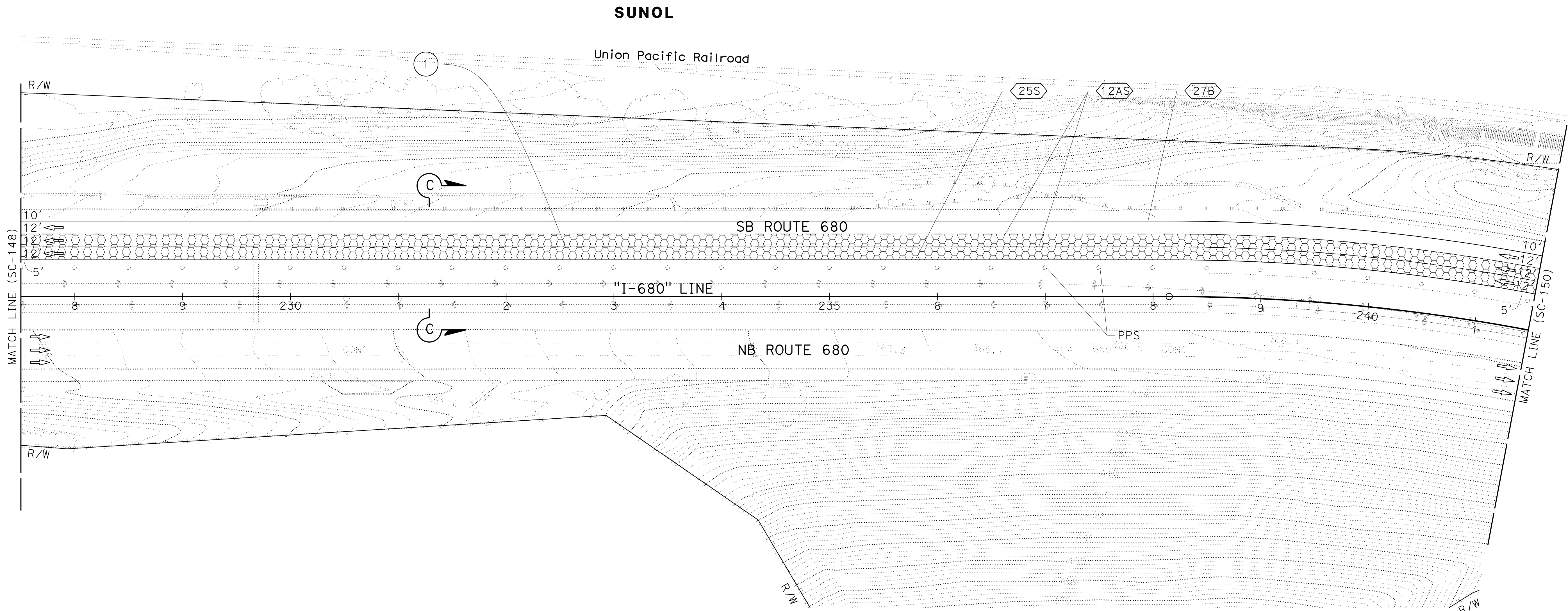

**STAGE CONSTRUCTION  
AND TRAFFIC HANDLING PLAN  
STAGE 3**

SCALE: 1" = 50'

**SC-149**

FOR NOTES, ABBREVIATIONS AND  
LEGEND, SEE SHEET SC-1 AND SC-144

APPROVED FOR STAGE CONSTRUCTION AND TRAFFIC HANDLING WORK ONLY

LAST REVISION: 09-29-21 DATE PLOTTED => 8-MAR-2022 TIME PLOTTED => 10:10

Dist	COUNTY	ROUTE	POST MILES TOTAL PROJECT	SHEET No.	TOTAL SHEETS
04	Ala, CC	680	R11.0/R21.9, R0.0/R0.9	663	1710

<i>Erin D. McPherson</i>	9-29-21
REGISTERED CIVIL ENGINEER	DATE
October 8, 2021	
PLANS APPROVAL DATE	

ERIN D. McPHERSON No. C91111 Exp. 3-31-24 CIVIL
-------------------------------------------------------------

WMH CORPORATION 55 South Market St Suite 1200 San Jose, CA 95113	ALAMEDA CTC 1111 Broadway Suite 800 Oakland, CA 94607
---------------------------------------------------------------------------	----------------------------------------------------------------

NOTE:  
FOR ACCURATE RIGHT OF WAY DATA, CONTACT  
RIGHT OF WAY ENGINEERING AT THE DISTRICT OFFICE.

REVISOR	DATE	REVISION
JV	9-29-21	
CALCULATED-DESIGNED BY	CHECKED BY	
JAMEY VALDIVIA	ERIN MCPHERSON	
CONSULTANT FUNCTIONAL SUPERVISOR		
TIMOTHY J. LEE		

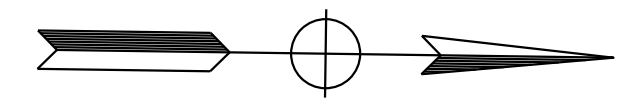

**SUNOL**

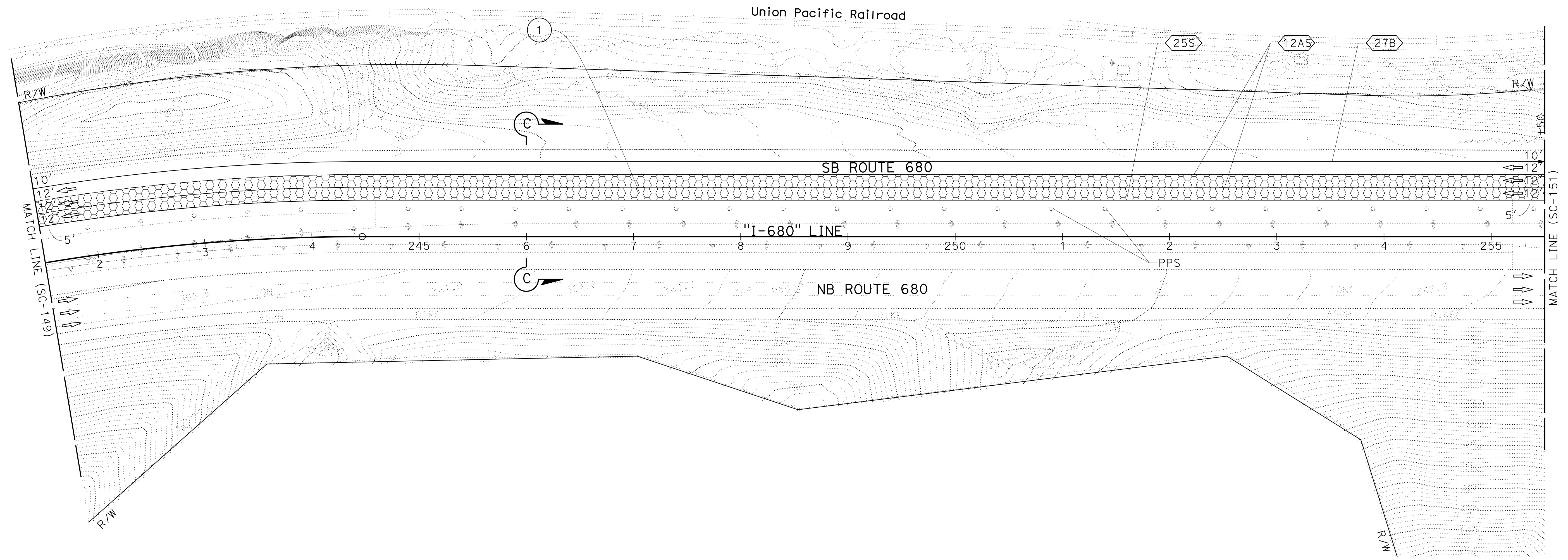

**STAGE CONSTRUCTION  
AND TRAFFIC HANDLING PLAN  
STAGE 3**

SCALE: 1" = 50'

**SC-150**

FOR NOTES, ABBREVIATIONS AND  
LEGEND, SEE SHEET SC-1 AND SC-144

APPROVED FOR STAGE CONSTRUCTION AND TRAFFIC HANDLING WORK ONLY

LAST REVISION: 09-29-21 DATE PLOTTED => 8-MAR-2022 TIME PLOTTED => 10:10

Dist	COUNTY	ROUTE	POST MILES TOTAL PROJECT	SHEET No.	TOTAL SHEETS
04	Ala, CC	680	R11.0/R21.9, R0.0/R0.9	664	1710

<i>Erin D. McPherson</i>	9-29-21
REGISTERED CIVIL ENGINEER	DATE
October 8, 2021	
PLANS APPROVAL DATE	

ERIN D. McPHERSON No. C91111 Exp. 3-31-24 CIVIL STATE OF CALIFORNIA
------------------------------------------------------------------------------------

WMH CORPORATION 55 South Market St Suite 1200 San Jose, CA 95113	ALAMEDA CTC 1111 Broadway Suite 800 Oakland, CA 94607
---------------------------------------------------------------------------	----------------------------------------------------------------

NOTE:  
FOR ACCURATE RIGHT OF WAY DATA, CONTACT  
RIGHT OF WAY ENGINEERING AT THE DISTRICT OFFICE.

X:\680\_SB\_EXPRESS\000\_CAD\Submittal\11\1\CADD\_submittal\0420000235ma151.dgn  
 STATE OF CALIFORNIA - DEPARTMENT OF TRANSPORTATION  
 CONSULTANT FUNCTIONAL SUPERVISOR  
 JAMEY VALDIVIA  
 ERIN MCPHERSON  
 TIMOTHY J. LEE  
 CALCULATED-DESIGNED BY  
 CHECKED BY  
 REVISOR BY  
 DATE REVISOR  
 JV  
 9-29-21

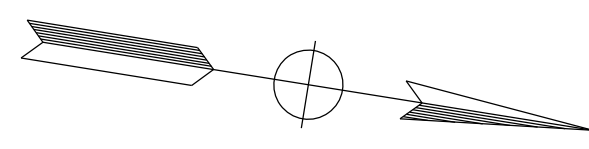
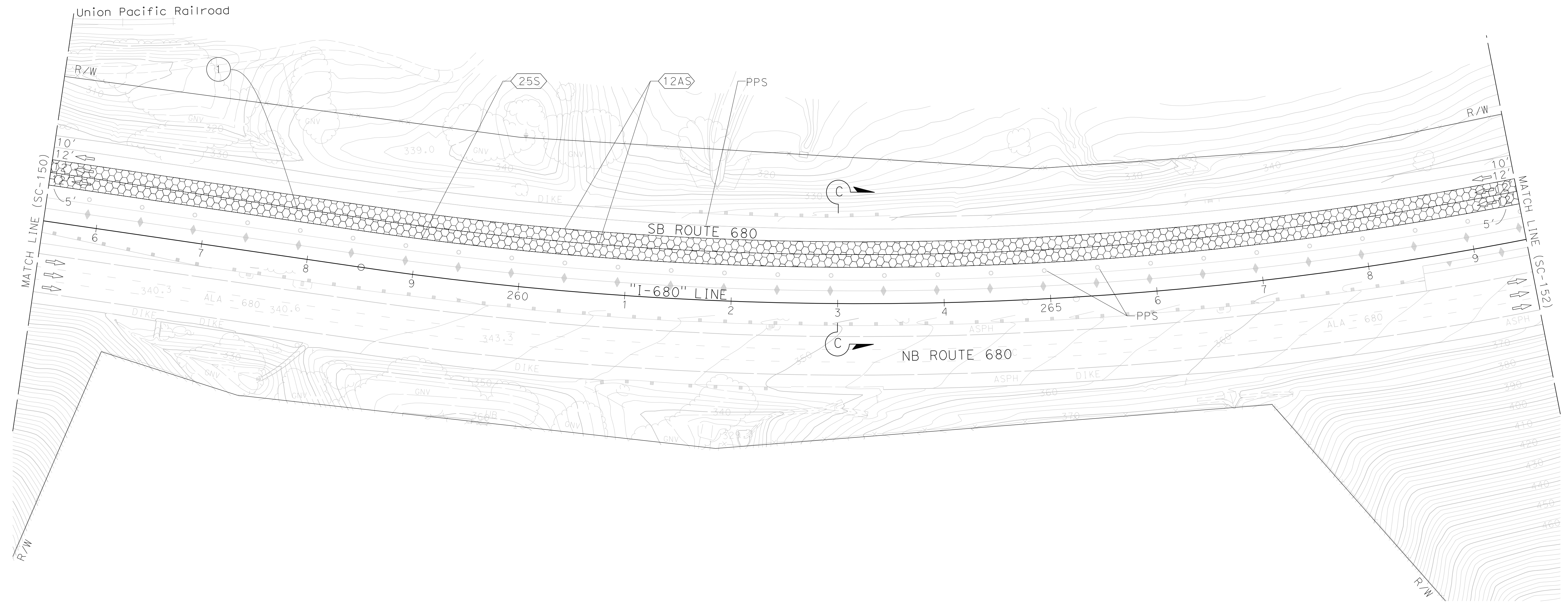

## STAGE CONSTRUCTION AND TRAFFIC HANDLING PLAN STAGE 3

SCALE: 1" = 50'

**SC-151**

FOR NOTES, ABBREVIATIONS AND  
LEGEND, SEE SHEET SC-1 AND SC-144

APPROVED FOR STAGE CONSTRUCTION AND TRAFFIC HANDLING WORK ONLY

LAST REVISION    DATE PLOTTED => 3/21/2022  
 09-29-21    TIME PLOTTED => 4:08:54 PM

X:\680\_SB\_EXPRESS\000\_CAD\Submit\101\101\CADD\_submit\101\101\0420000235ma152.dgn  
 STATE OF CALIFORNIA - DEPARTMENT OF TRANSPORTATION  
 CONSULTANT FUNCTIONAL SUPERVISOR: TIMOTHY J. LEE  
 CALCULATED/DESIGNED BY: JAMEY VALDIVIA  
 CHECKED BY: ERIN MCPHERSON  
 REVISED BY: J.V.  
 DATE REVISED: 9-29-21

NOTE:  
 FOR ACCURATE RIGHT OF WAY DATA, CONTACT  
 RIGHT OF WAY ENGINEERING AT THE DISTRICT OFFICE.

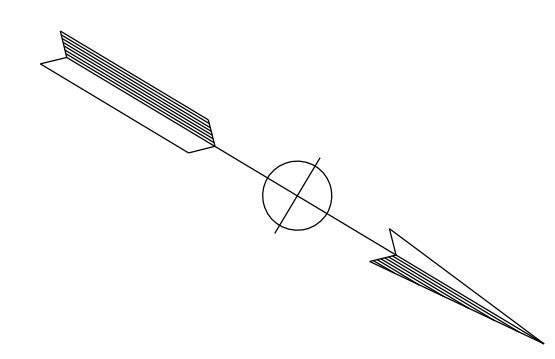

Dist	COUNTY	ROUTE	POST MILES TOTAL PROJECT	SHEET No.	TOTAL SHEETS
04	Ala, CC	680	R11.0/R21.9, RO.0/RO.9	665	1710
			9-29-21		
REGISTERED CIVIL ENGINEER			DATE		
October 8, 2021			PLANS APPROVAL DATE		
<small>THE STATE OF CALIFORNIA OR ITS OFFICERS OR AGENTS SHALL NOT BE RESPONSIBLE FOR THE ACCURACY OR COMPLETENESS OF SCANNED COPIES OF THIS PLAN SHEET.</small>					
WMH CORPORATION 55 South Market St Suite 1200 San Jose, CA 95113			ALAMEDA CTC 1111 Broadway Suite 800 Oakland, CA 94607		

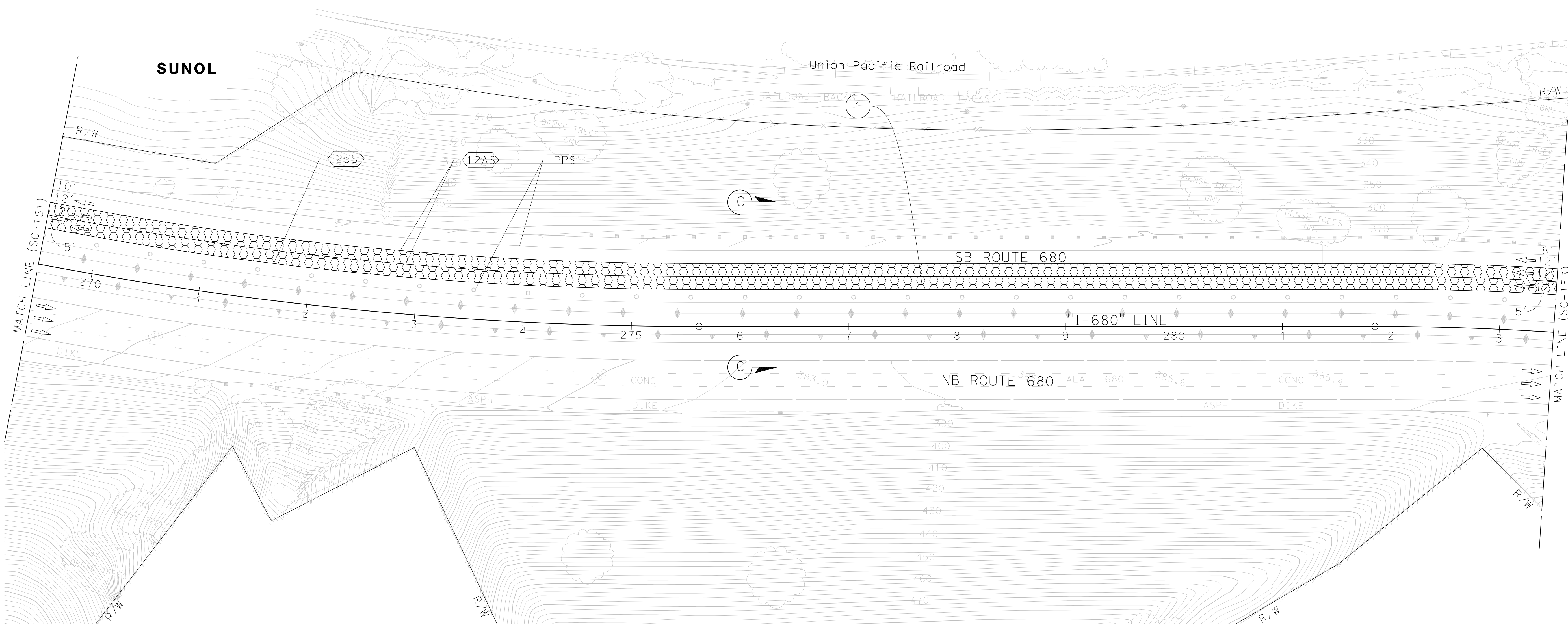

FOR NOTES, ABBREVIATIONS AND LEGEND, SEE SHEET SC-1 AND SC-144

APPROVED FOR STAGE CONSTRUCTION AND TRAFFIC HANDLING WORK ONLY

## STAGE CONSTRUCTION AND TRAFFIC HANDLING PLAN STAGE 3

SCALE: 1" = 50'

**SC-152**

LAST REVISION: DATE PLOTTED => 3/21/2022, 09-29-21 | TIME PLOTTED => 4:09:00 PM

Dist	COUNTY	ROUTE	POST MILES TOTAL PROJECT	SHEET No.	TOTAL SHEETS
04	Ala, CC	680	R11.0/R21.9, RO.0/RO.9	666	1710
			REGISTERED CIVIL ENGINEER	DATE	
			Erin D. McPherson	9-29-21	
			PLANS APPROVAL DATE		
			October 8, 2021		
WMH CORPORATION			ALAMEDA CTC		
55 South Market St			1111 Broadway		
Suite 1200			Suite 800		
San Jose, CA 95113			Oakland, CA 94607		

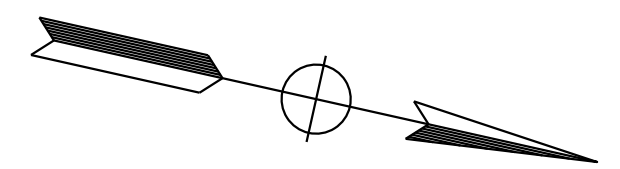

**NOTE:**  
FOR ACCURATE RIGHT OF WAY DATA, CONTACT RIGHT OF WAY ENGINEERING AT THE DISTRICT OFFICE.

O:\00300\DRAWING\FINAL\_P5&E\0420000235m0153.dgn  
 STATE OF CALIFORNIA - DEPARTMENT OF TRANSPORTATION  
 Er Catrans®  
 USERNAME => p302438  
 DGN FILE => 0420000235m0153.dgn

CALCULATED/DESIGNED BY	JAMEY VALDIVIA
CHECKED BY	ERIN MCPHERSON
CONSULTANT FUNCTIONAL SUPERVISOR	TIMOTHY J. LEE
REVISOR	JV
DATE REVISED	9-29-21

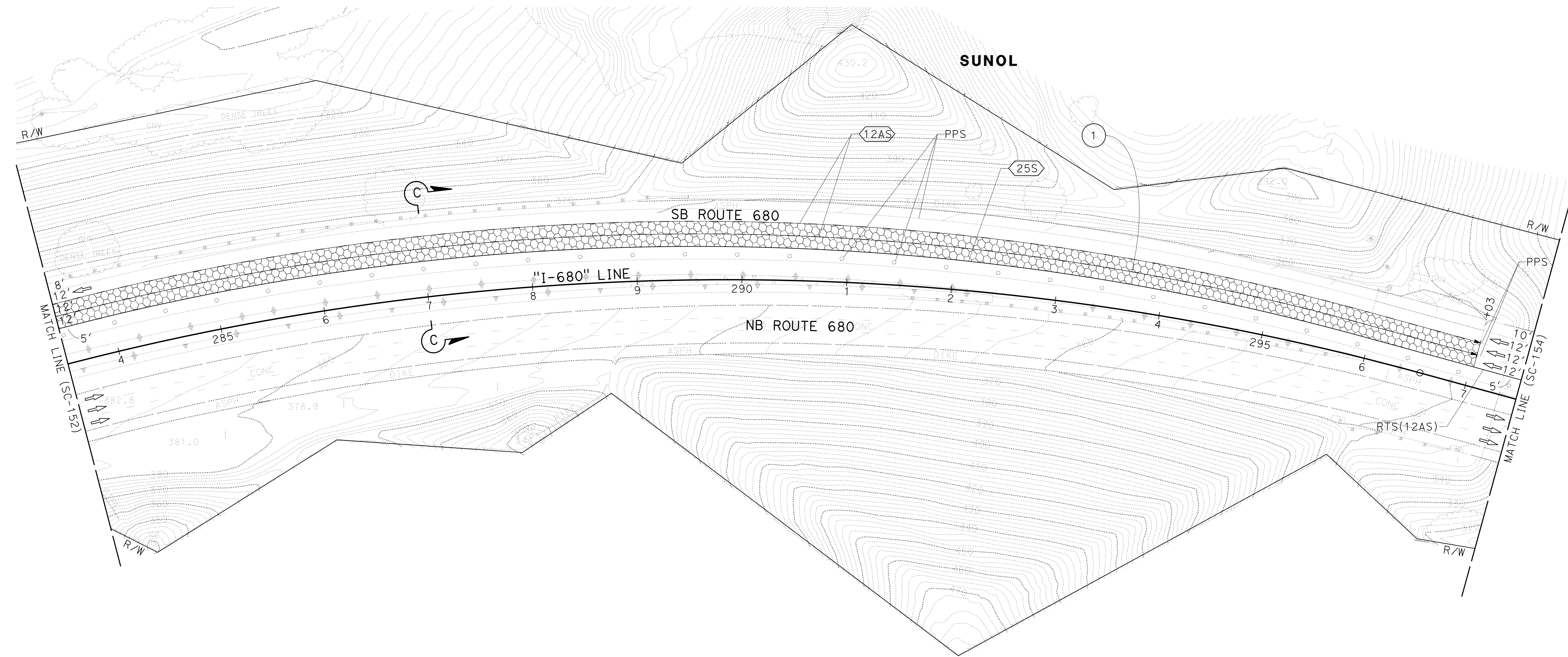

FOR NOTES, ABBREVIATIONS AND LEGEND, SEE SHEET SC-1 AND SC-144

APPROVED FOR STAGE CONSTRUCTION AND TRAFFIC HANDLING WORK ONLY

**STAGE CONSTRUCTION AND TRAFFIC HANDLING PLAN  
STAGE 3**

SCALE: 1" = 50'

**SC-153**

LAST REVISION: DATE PLOTTED => 8-MAR-2022  
 09-29-21 TIME PLOTTED => 10:10

Dist	COUNTY	ROUTE	POST MILES TOTAL PROJECT	SHEET No.	TOTAL SHEETS
04	Ala, CC	680	R11.0/R21.9, R0.0/R0.9	667	1710
			9-29-21		
REGISTERED CIVIL ENGINEER			DATE		
			October 8, 2021		
			PLANS APPROVAL DATE		
<small>THE STATE OF CALIFORNIA OR ITS OFFICERS OR AGENTS SHALL NOT BE RESPONSIBLE FOR THE ACCURACY OR COMPLETENESS OF SCANNED COPIES OF THIS PLAN SHEET.</small>					
WMH CORPORATION 55 South Market St Suite 1200 San Jose, CA 95113			ALAMEDA CTC 1111 Broadway Suite 800 Oakland, CA 94607		

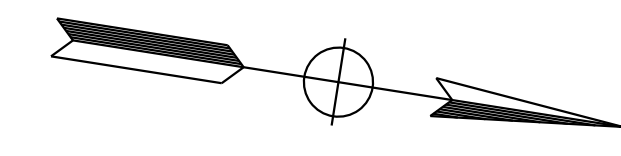

NOTE:  
FOR ACCURATE RIGHT OF WAY DATA, CONTACT  
RIGHT OF WAY ENGINEERING AT THE DISTRICT OFFICE.

STATE OF CALIFORNIA - DEPARTMENT OF TRANSPORTATION	CONSULTANT	FUNCTIONAL SUPERVISOR	DESIGNED BY	REVISOR	DATE
	JAMEY VALDIVIA	TIMOTHY J. LEE	ERIN MCPHERSON	JV	9-29-21
	ERIN MCPHERSON				

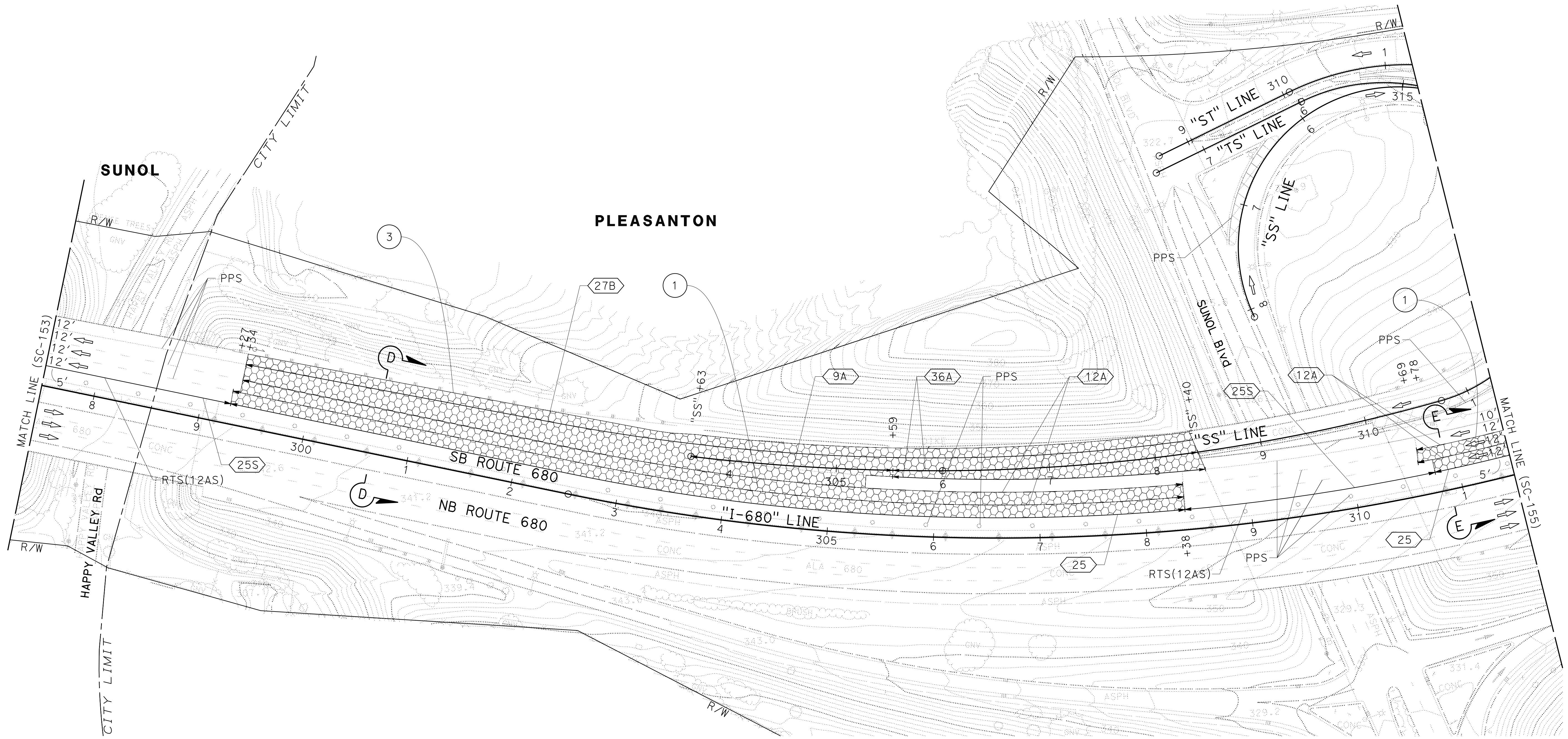

FOR NOTES, ABBREVIATIONS AND  
LEGEND, SEE SHEET SC-1 AND SC-144

APPROVED FOR STAGE CONSTRUCTION AND TRAFFIC HANDLING WORK ONLY

**STAGE CONSTRUCTION  
AND TRAFFIC HANDLING PLAN  
STAGE 3**

SCALE: 1" = 50'

**SC-154**

LAST REVISION DATE PLOTTED => 8-MAR-2022 09-29-21 TIME PLOTTED => 10:11

NOTE:  
FOR ACCURATE RIGHT OF WAY DATA, CONTACT  
RIGHT OF WAY ENGINEERING AT THE DISTRICT OFFICE.

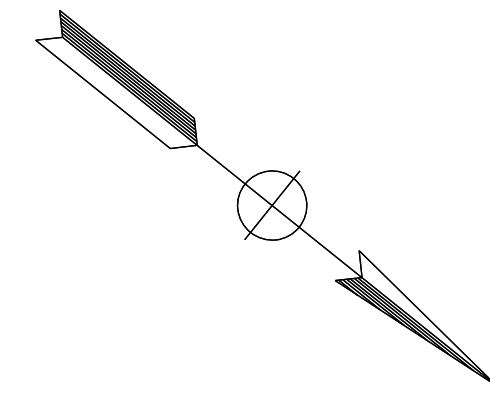

Dist	COUNTY	ROUTE	POST MILES TOTAL PROJECT	SHEET No.	TOTAL SHEETS
04	Ala, CC	680	R11.0/R21.9, R0.0/R0.9	668	1710
			REGISTERED CIVIL ENGINEER DATE 9-29-21 October 8, 2021 PLANS APPROVAL DATE		
WMH CORPORATION 55 South Market St Suite 1200 San Jose, CA 95113			ALAMEDA CTC 1111 Broadway Suite 800 Oakland, CA 94607		

CALCULATED- DESIGNED BY	REVISOR	DATE	REVISOR	DATE
CHECKED BY	DATE	REVISOR	DATE	REVISOR
CONSULTANT FUNCTIONAL SUPERVISOR	DATE	REVISOR	DATE	REVISOR
DEPARTMENT OF TRANSPORTATION	DATE	REVISOR	DATE	REVISOR
STATE OF CALIFORNIA	DATE	REVISOR	DATE	REVISOR
	DATE	REVISOR	DATE	REVISOR
	DATE	REVISOR	DATE	REVISOR
	DATE	REVISOR	DATE	REVISOR
	DATE	REVISOR	DATE	REVISOR
	DATE	REVISOR	DATE	REVISOR

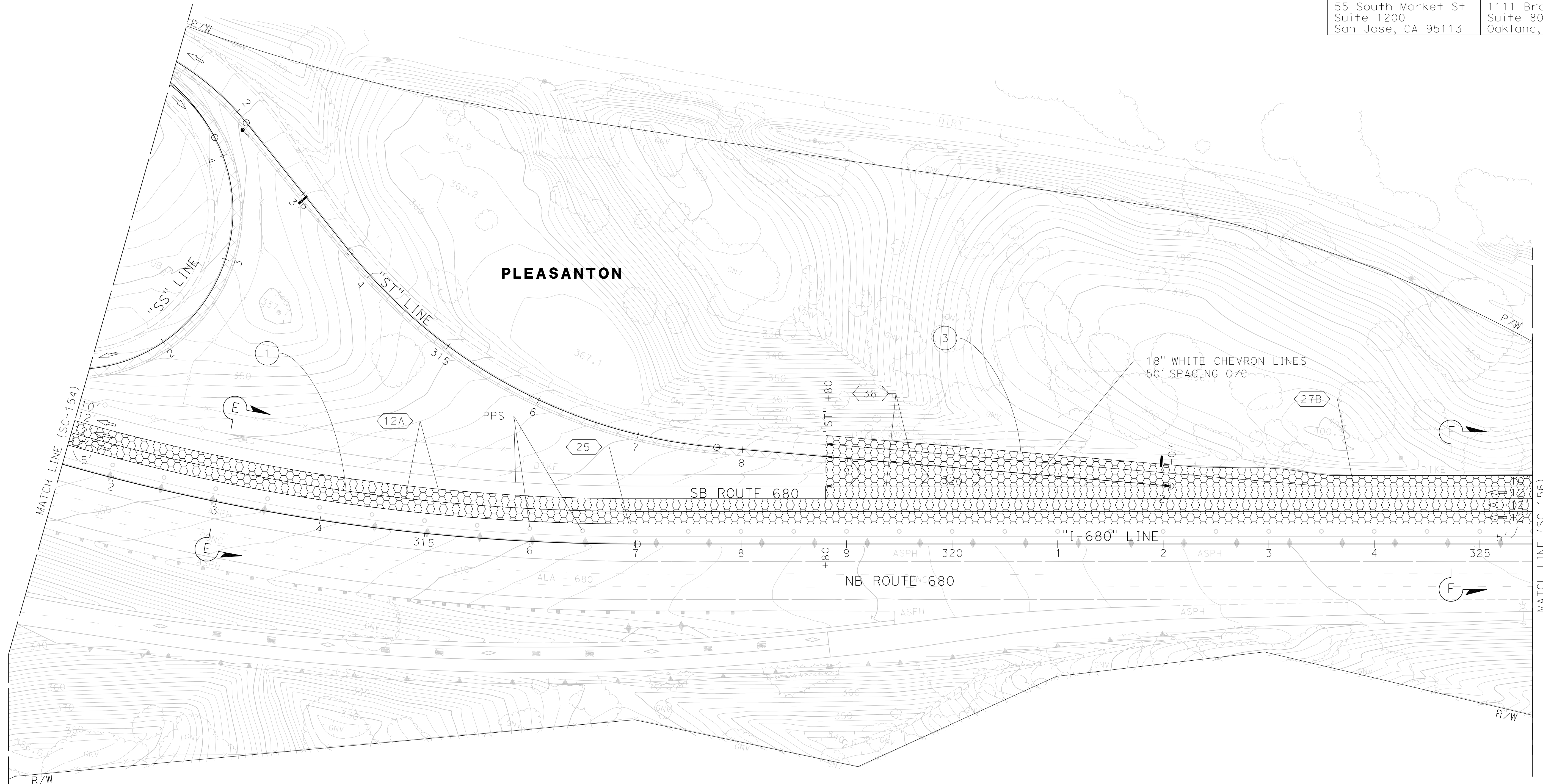

FOR NOTES, ABBREVIATIONS AND  
LEGEND, SEE SHEET SC-1 AND SC-144

APPROVED FOR STAGE CONSTRUCTION AND TRAFFIC HANDLING WORK ONLY

**STAGE CONSTRUCTION  
AND TRAFFIC HANDLING PLAN  
STAGE 3**

SCALE: 1" = 50'

**SC-155**

LAST REVISION DATE PLOTTED => 3/21/2022 09-29-21 TIME PLOTTED => 4:09:15 PM



NOTE:  
 FOR ACCURATE RIGHT OF WAY DATA, CONTACT  
 RIGHT OF WAY ENGINEERING AT THE DISTRICT OFFICE.

Dist	COUNTY	ROUTE	POST MILES TOTAL PROJECT	SHEET No.	TOTAL SHEETS
04	Ala, CC	680	R11.0/R21.9, RO.0/RO.9	670	1710
			9-29-21		
REGISTERED CIVIL ENGINEER			DATE		
			October 8, 2021		
			PLANS APPROVAL DATE		
<small>THE STATE OF CALIFORNIA OR ITS OFFICERS OR AGENTS SHALL NOT BE RESPONSIBLE FOR THE ACCURACY OR COMPLETENESS OF SCANNED COPIES OF THIS PLAN SHEET.</small>					
WMH CORPORATION 55 South Market St Suite 1200 San Jose, CA 95113			ALAMEDA CTC 1111 Broadway Suite 800 Oakland, CA 94607		

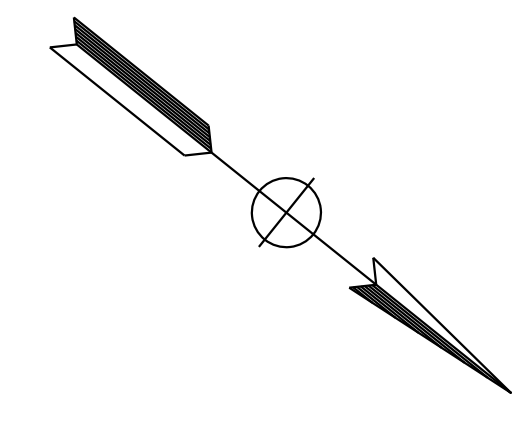

			JV	9-29-21	
			REVISOR	DATE	
	JAMEY VALDIVIA				
	ERIN MCPHERSON				
	CHECKED BY				
	TIMOTHY J. LEE				
	CONSULTANT				
	FUNCTIONAL SUPERVISOR				
	DESIGNED BY				
	CALCULATED BY				

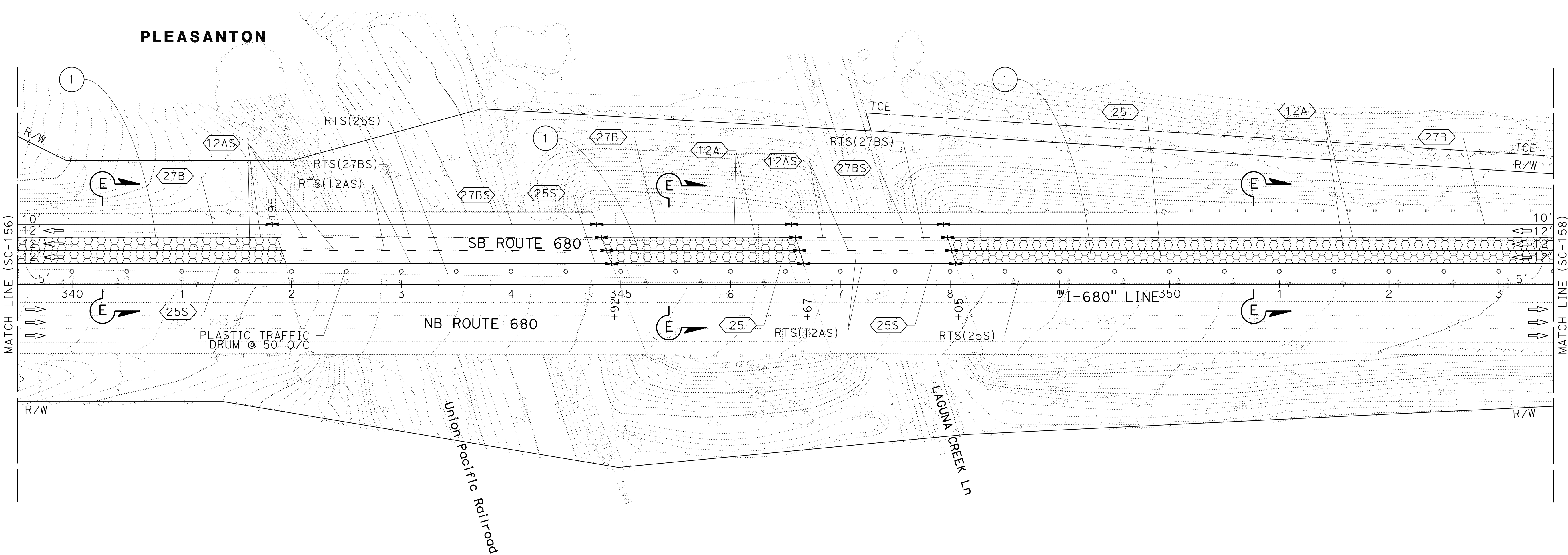

FOR NOTES, ABBREVIATIONS AND  
 LEGEND, SEE SHEET SC-1 AND SC-144

APPROVED FOR STAGE CONSTRUCTION AND TRAFFIC HANDLING WORK ONLY

### STAGE CONSTRUCTION AND TRAFFIC HANDLING PLAN STAGE 3

SCALE: 1" = 50'

**SC-157**

X:\680\_SB\_EXPRESS\000\_CAD\Submittal\0420000235ma158.dgn  
 STATE OF CALIFORNIA - DEPARTMENT OF TRANSPORTATION  
 CONSULTANT FUNCTIONAL SUPERVISOR  
 JAMEY VALDIVIA  
 ERIN MCPHERSON  
 TIMOTHY J. LEE  
 CHECKED BY  
 DESIGNED BY  
 REVISIONS  
 REVISED BY  
 DATE REVISED  
 JV  
 9-29-21

NOTE:  
 FOR ACCURATE RIGHT OF WAY DATA, CONTACT  
 RIGHT OF WAY ENGINEERING AT THE DISTRICT OFFICE.

Dist	COUNTY	ROUTE	POST MILES TOTAL PROJECT	SHEET No.	TOTAL SHEETS
04	Ala, CC	680	R11.0/R21.9, R0.0/R0.9	671	1710

ERIN D. McPHERSON  
 REGISTERED CIVIL ENGINEER  
 No. C91111  
 Exp. 3-31-24  
 CIVIL  
 STATE OF CALIFORNIA

9-29-21  
 DATE  
 REGISTERED CIVIL ENGINEER

October 8, 2021  
 PLANS APPROVAL DATE

THE STATE OF CALIFORNIA OR ITS OFFICERS  
 OR AGENTS SHALL NOT BE RESPONSIBLE FOR  
 THE ACCURACY OR COMPLETENESS OF SCANNED  
 COPIES OF THIS PLAN SHEET.

WMH CORPORATION 55 South Market St Suite 1200 San Jose, CA 95113	ALAMEDA CTC 1111 Broadway Suite 800 Oakland, CA 94607
---------------------------------------------------------------------------	----------------------------------------------------------------

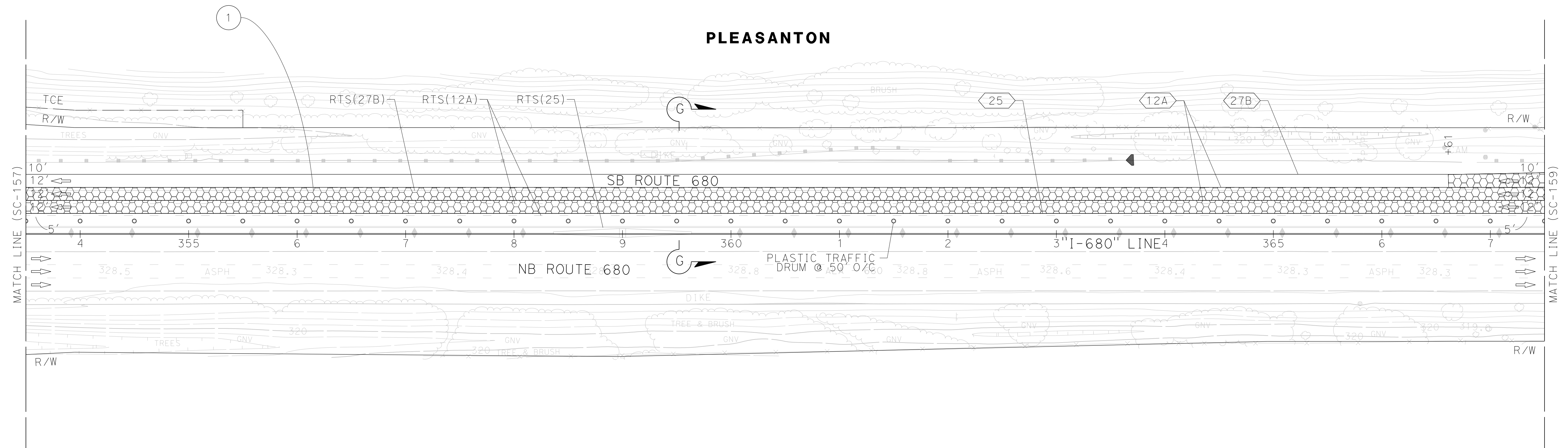
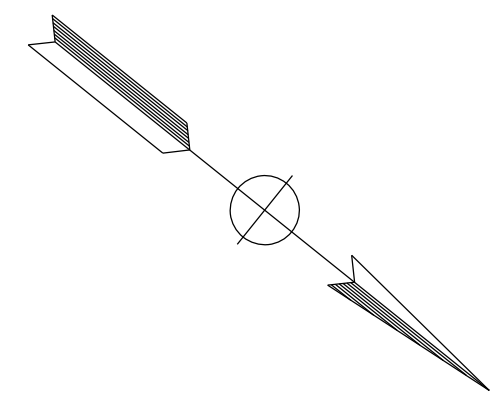

FOR NOTES, ABBREVIATIONS AND  
 LEGEND, SEE SHEET SC-1 AND SC-144

APPROVED FOR STAGE CONSTRUCTION AND TRAFFIC HANDLING WORK ONLY

## STAGE CONSTRUCTION AND TRAFFIC HANDLING PLAN STAGE 3

SCALE: 1" = 50'

**SC-158**

LAST REVISION  
 09-29-21  
 DATE PLOTTED => 3/21/2022  
 TIME PLOTTED => 4:09:30 PM

Dist	COUNTY	ROUTE	POST MILES TOTAL PROJECT	SHEET No.	TOTAL SHEETS
04	Ala, CC	680	R11.0/R21.9, RO.0/RO.9	672	1710

<i>Erin D. McPherson</i>	9-29-21
REGISTERED CIVIL ENGINEER	DATE
October 8, 2021	
PLANS APPROVAL DATE	

  

REGISTERED PROFESSIONAL ENGINEER <b>ERIN D. MCPHERSON</b> No. C91111 Exp. 3-31-24 CIVIL STATE OF CALIFORNIA
----------------------------------------------------------------------------------------------------------------------------

WMH CORPORATION 55 South Market St Suite 1200 San Jose, CA 95113	ALAMEDA CTC 1111 Broadway Suite 800 Oakland, CA 94607
---------------------------------------------------------------------------	----------------------------------------------------------------

NOTE:  
 FOR ACCURATE RIGHT OF WAY DATA, CONTACT  
 RIGHT OF WAY ENGINEERING AT THE DISTRICT OFFICE.

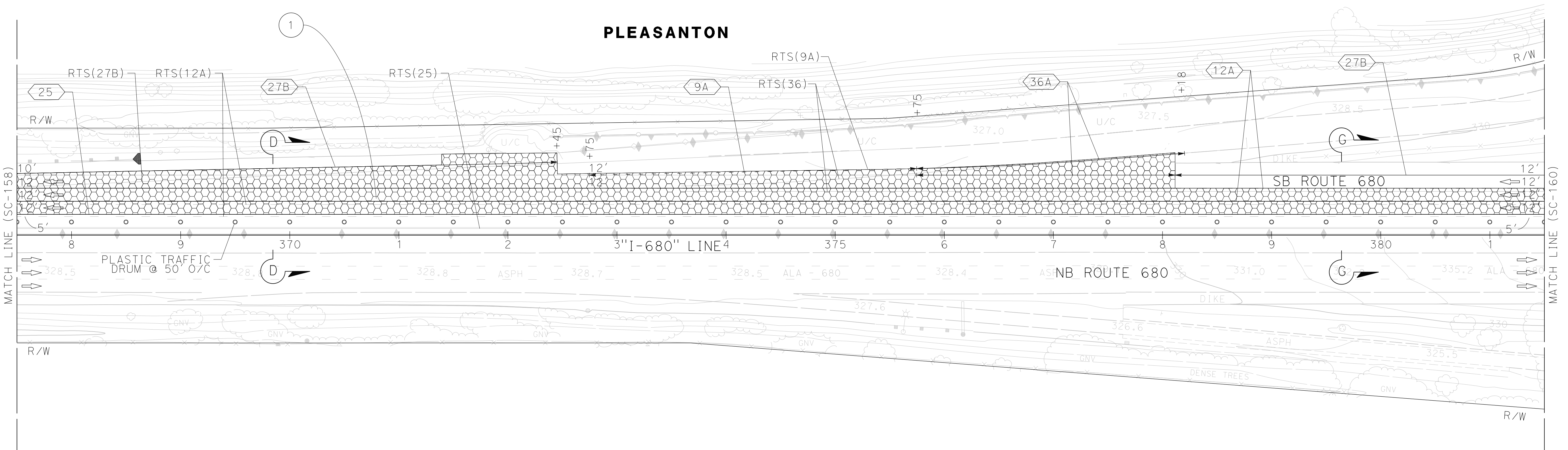
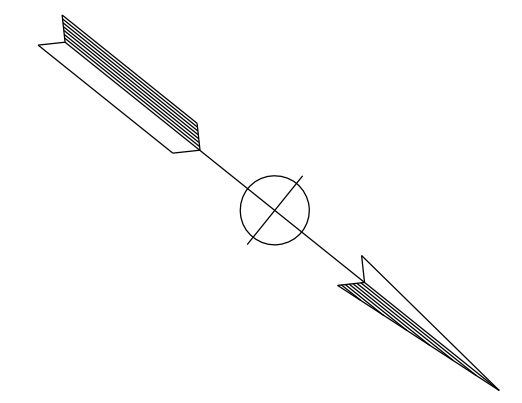

**STAGE CONSTRUCTION  
 AND TRAFFIC HANDLING PLAN  
 STAGE 3**

SCALE: 1" = 50'

**SC-159**

FOR NOTES, ABBREVIATIONS AND  
 LEGEND, SEE SHEET SC-1 AND SC-144

APPROVED FOR STAGE CONSTRUCTION AND TRAFFIC HANDLING WORK ONLY

X:\680\_SB\_EXPRESS\000\_CAD\Submittal\0420000235ma159.dgn  
 STATE OF CALIFORNIA - DEPARTMENT OF TRANSPORTATION  
 CONSULTANT FUNCTIONAL SUPERVISOR  
 JAMEY VALDIVIA  
 ERIN MCPHERSON  
 TIMOTHY J. LEE  
 CHECKED BY  
 DESIGNED BY  
 REVISIONS  
 REVISED BY  
 DATE REVISED  
 JV  
 9-29-21

Dist	COUNTY	ROUTE	POST MILES TOTAL PROJECT	SHEET No.	TOTAL SHEETS
04	Ala, CC	680	R11.0/R21.9, R0.0/R0.9	673	1710
			9-29-21		
ERIN D. McPHERSON			DATE		
REGISTERED CIVIL ENGINEER			October 8, 2021		
			PLANS APPROVAL DATE		
<small>THE STATE OF CALIFORNIA OR ITS OFFICERS OR AGENTS SHALL NOT BE RESPONSIBLE FOR THE ACCURACY OR COMPLETENESS OF SCANNED COPIES OF THIS PLAN SHEET.</small>					
WMH CORPORATION 55 South Market St Suite 1200 San Jose, CA 95113			ALAMEDA CTC 1111 Broadway Suite 800 Oakland, CA 94607		



NOTES:  
 1. FOR ACCURATE RIGHT OF WAY DATA, CONTACT RIGHT OF WAY ENGINEERING AT THE DISTRICT OFFICE.  
 2. PLACE FINAL PAVEMENT DELINEATION FOR BERNAL RAMP, AFTER WIDENING AND OVERLAY COMPLETION. FOR DETAILS SEE PD SHEETS.

REVISOR	DATE	REVISION
JV	9-29-21	
JAMEY VALDIVIA		
ERIN McPHERSON		
CALCULATED/DESIGNED BY	CHECKED BY	
TIMOTHY J. LEE		
CONSULTANT FUNCTIONAL SUPERVISOR		
DEPARTMENT OF TRANSPORTATION		

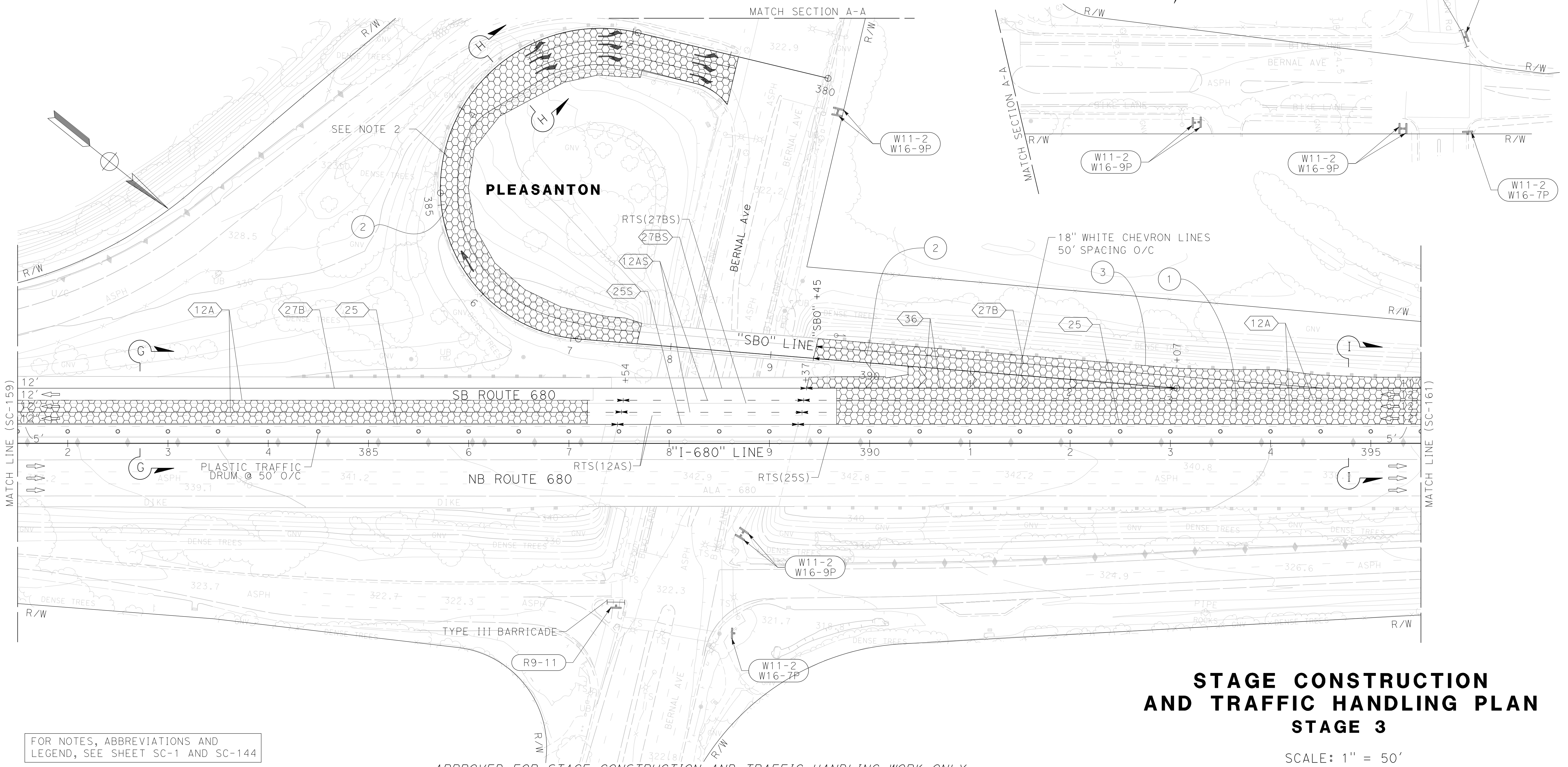

FOR NOTES, ABBREVIATIONS AND LEGEND, SEE SHEET SC-1 AND SC-144

APPROVED FOR STAGE CONSTRUCTION AND TRAFFIC HANDLING WORK ONLY

## STAGE CONSTRUCTION AND TRAFFIC HANDLING PLAN

### STAGE 3

SCALE: 1" = 50'

**SC-160**

LAST REVISION      DATE PLOTTED => 3/21/2022      09-29-21      TIME PLOTTED => 4:09:36 PM

Dist	COUNTY	ROUTE	POST MILES TOTAL PROJECT	SHEET No.	TOTAL SHEETS
04	Ala, CC	680	R11.0/R21.9, RO.0/RO.9	674	1710
			9-29-21		
REGISTERED CIVIL ENGINEER			DATE		
October 8, 2021			PLANS APPROVAL DATE		
WMH CORPORATION 55 South Market St Suite 1200 San Jose, CA 95113			ALAMEDA CTC 1111 Broadway Suite 800 Oakland, CA 94607		

NOTE:  
FOR ACCURATE RIGHT OF WAY DATA, CONTACT  
RIGHT OF WAY ENGINEERING AT THE DISTRICT OFFICE.

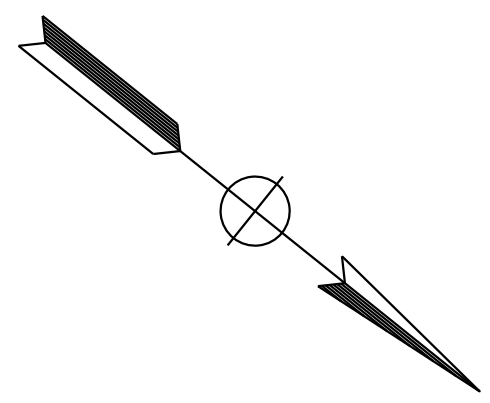

REVISOR	DATE	REVISION
JV	9-29-21	
CALCULATED/DESIGNED BY: JAMEY VALDIVIA CHECKED BY: ERIN MCPHERSON CONSULTANT SUPERVISOR: TIMOTHY J. LEE		

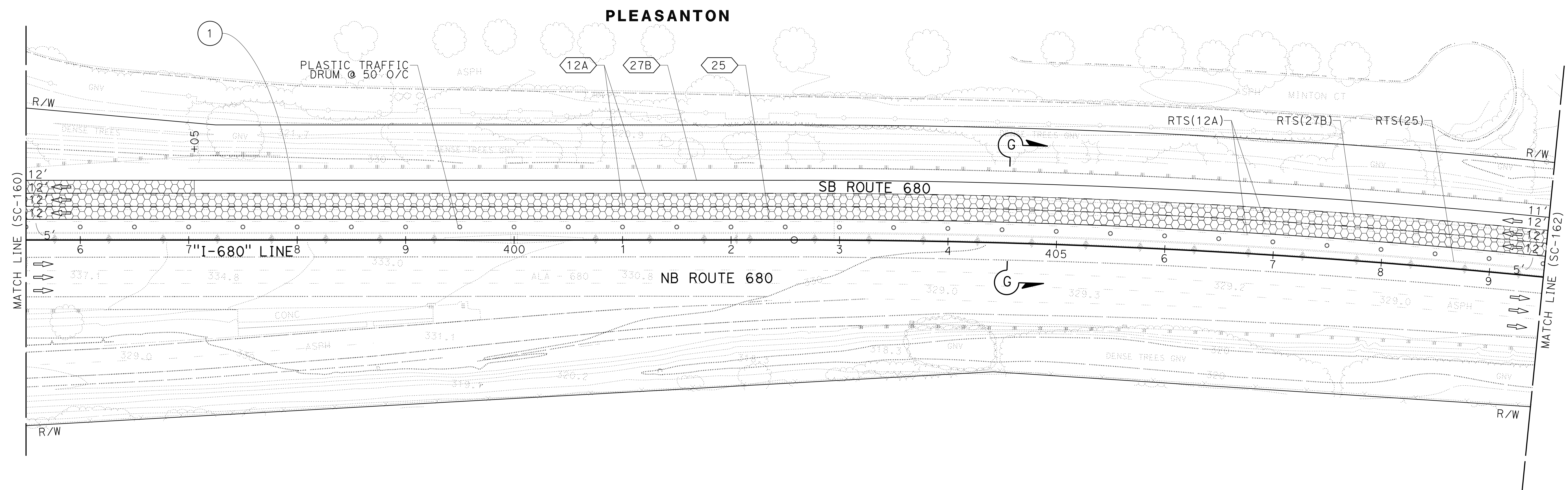

FOR NOTES, ABBREVIATIONS AND  
LEGEND, SEE SHEET SC-1 AND SC-144

APPROVED FOR STAGE CONSTRUCTION AND TRAFFIC HANDLING WORK ONLY

**STAGE CONSTRUCTION  
AND TRAFFIC HANDLING PLAN  
STAGE 3**

SCALE: 1" = 50'

**SC-161**

Dist	COUNTY	ROUTE	POST MILES TOTAL PROJECT	SHEET No.	TOTAL SHEETS
04	Ala, CC	680	R11.0/R21.9, R0.0/R0.9	675	1710
			9-29-21		
REGISTERED CIVIL ENGINEER			DATE		
			October 8, 2021		
			PLANS APPROVAL DATE		
<small>THE STATE OF CALIFORNIA OR ITS OFFICERS OR AGENTS SHALL NOT BE RESPONSIBLE FOR THE ACCURACY OR COMPLETENESS OF SCANNED COPIES OF THIS PLAN SHEET.</small>					
WMH CORPORATION 55 South Market St Suite 1200 San Jose, CA 95113			ALAMEDA CTC 1111 Broadway Suite 800 Oakland, CA 94607		

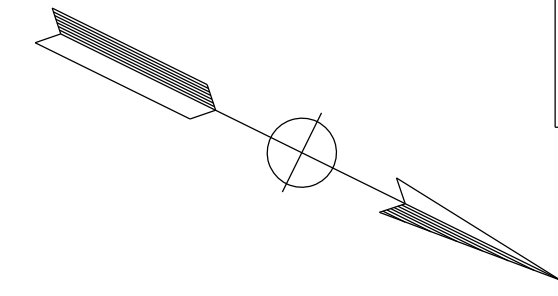
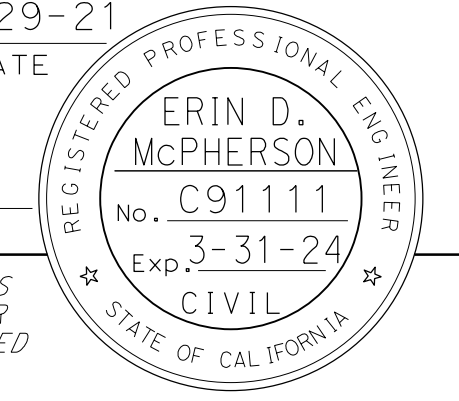

NOTE:  
FOR ACCURATE RIGHT OF WAY DATA, CONTACT  
RIGHT OF WAY ENGINEERING AT THE DISTRICT OFFICE.

DESIGNED BY	JAMEY VALDIVIA
CHECKED BY	ERIN MCPHERSON
FUNCTIONAL SUPERVISOR	TIMOTHY J. LEE
CONSULTANT	DEPARTMENT OF TRANSPORTATION
STATE OF CALIFORNIA	DEPARTMENT OF TRANSPORTATION

REVISOR	JV
DATE	9-29-21

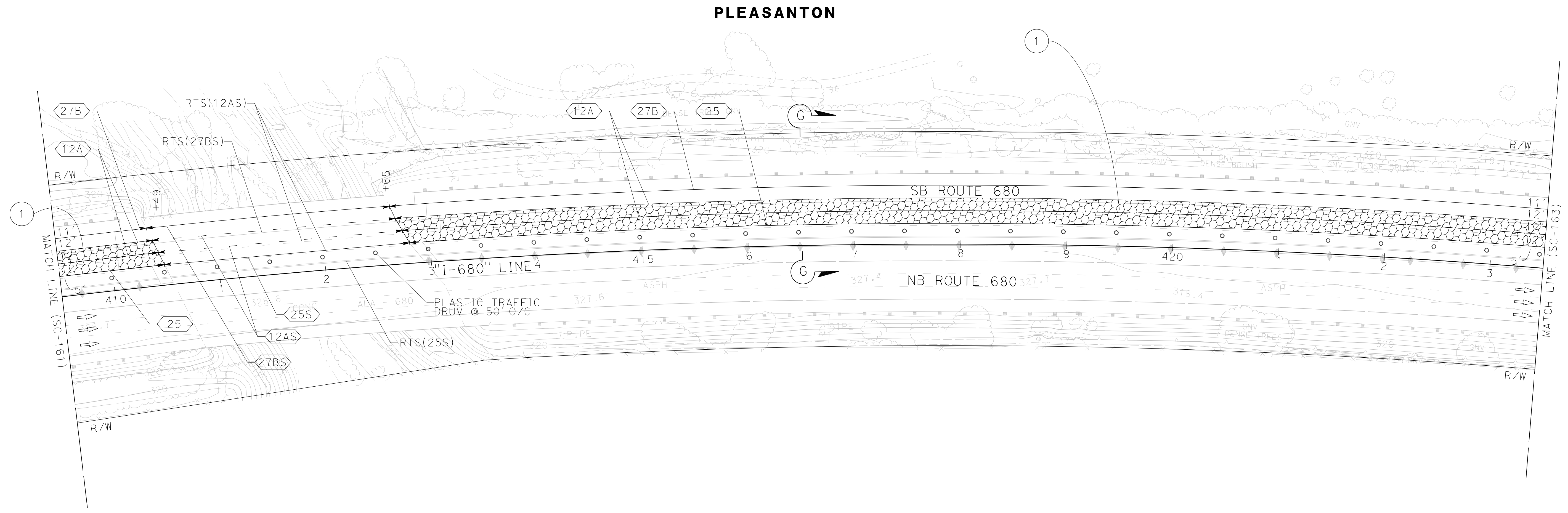

## STAGE CONSTRUCTION AND TRAFFIC HANDLING PLAN STAGE 3

SCALE: 1" = 50'

**SC-162**

FOR NOTES, ABBREVIATIONS AND  
LEGEND, SEE SHEET SC-1 AND SC-144

APPROVED FOR STAGE CONSTRUCTION AND TRAFFIC HANDLING WORK ONLY

X:\680\_SB\_EXPRESS\000\_CAD\Submittal\0420000235ma163.dgn  
 STATE OF CALIFORNIA - DEPARTMENT OF TRANSPORTATION  
 CONSULTANT FUNCTIONAL SUPERVISOR  
 JAMEY VALDIVIA  
 ERIN MCPHERSON  
 CHECKED BY  
 TIMOTHY J. LEE  
 REVISIONS  
 REVISED BY  
 DATE REVISED  
 JV  
 9-29-21

NOTE:  
 FOR ACCURATE RIGHT OF WAY DATA, CONTACT  
 RIGHT OF WAY ENGINEERING AT THE DISTRICT OFFICE.

Dist	COUNTY	ROUTE	POST MILES TOTAL PROJECT	SHEET No.	TOTAL SHEETS
04	Ala, CC	680	R11.0/R21.9, R0.0/R0.9	676	1710

REGISTERED CIVIL ENGINEER DATE 9-29-21  
 ERIN D. MCPHERSON  
 No. C91111  
 Exp. 3-31-24  
 CIVIL  
 STATE OF CALIFORNIA

October 8, 2021  
 PLANS APPROVAL DATE

THE STATE OF CALIFORNIA OR ITS OFFICERS  
 OR AGENTS SHALL NOT BE RESPONSIBLE FOR  
 THE ACCURACY OR COMPLETENESS OF SCANNED  
 COPIES OF THIS PLAN SHEET.

WMH CORPORATION 55 South Market St Suite 1200 San Jose, CA 95113	ALAMEDA CTC 1111 Broadway Suite 800 Oakland, CA 94607
---------------------------------------------------------------------------	----------------------------------------------------------------

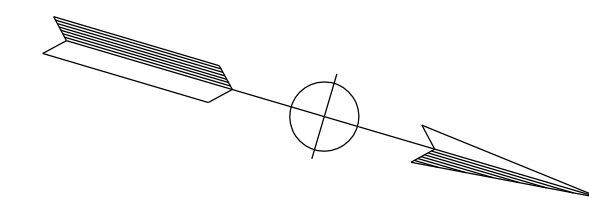

**PLEASANTON**

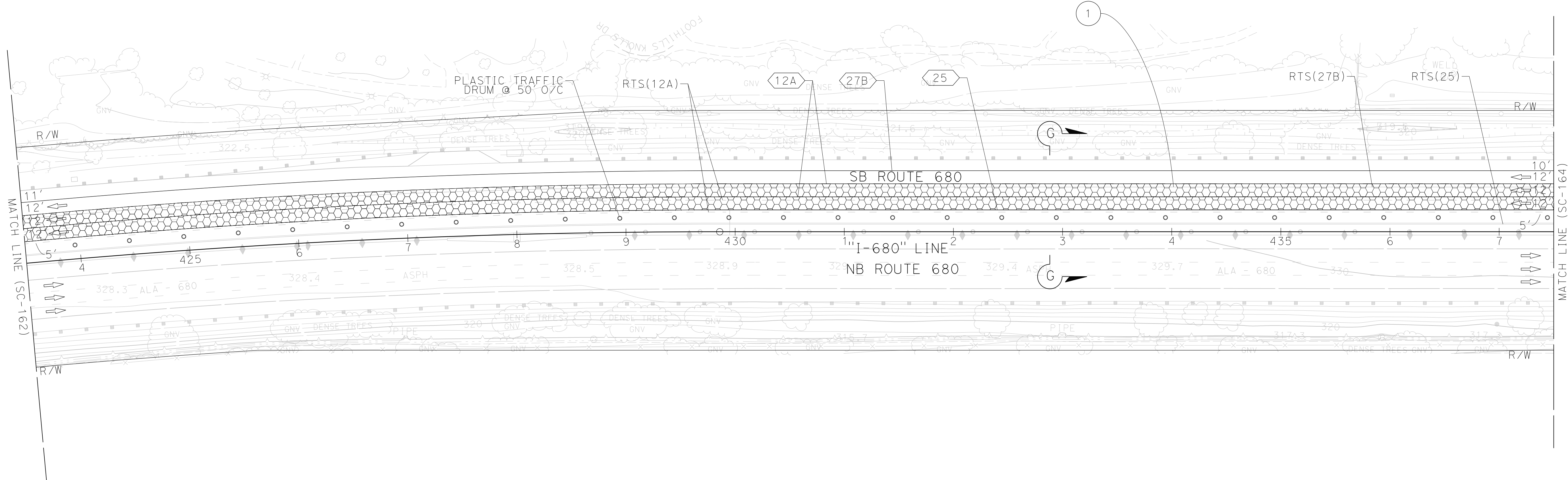

FOR NOTES, ABBREVIATIONS AND  
 LEGEND, SEE SHEET SC-1 AND SC-144

APPROVED FOR STAGE CONSTRUCTION AND TRAFFIC HANDLING WORK ONLY

**STAGE CONSTRUCTION  
 AND TRAFFIC HANDLING PLAN  
 STAGE 3**

SCALE: 1" = 50'

**SC-163**

LAST REVISION DATE PLOTTED => 3/21/2022  
 09-29-21 TIME PLOTTED => 4:09:48 PM

X:\680\_SB\_EXPRESS\000\_CAD\Submittal\0420000235ma164.dgn  
 STATE OF CALIFORNIA - DEPARTMENT OF TRANSPORTATION  
 CONSULTANT FUNCTIONAL SUPERVISOR  
 JAMEY VALDIVIA  
 ERIN MCPHERSON  
 TIMOTHY J. LEE  
 REVISIONS: 1, 2, 3, 4, 5, 6, 7, 8, 9, 10, 11, 12, 13, 14, 15, 16, 17, 18, 19, 20, 21, 22, 23, 24, 25, 26, 27, 28, 29, 30, 31, 32, 33, 34, 35, 36, 37, 38, 39, 40, 41, 42, 43, 44, 45, 46, 47, 48, 49, 50, 51, 52, 53, 54, 55, 56, 57, 58, 59, 60, 61, 62, 63, 64, 65, 66, 67, 68, 69, 70, 71, 72, 73, 74, 75, 76, 77, 78, 79, 80, 81, 82, 83, 84, 85, 86, 87, 88, 89, 90, 91, 92, 93, 94, 95, 96, 97, 98, 99, 100, 101, 102, 103, 104, 105, 106, 107, 108, 109, 110, 111, 112, 113, 114, 115, 116, 117, 118, 119, 120, 121, 122, 123, 124, 125, 126, 127, 128, 129, 130, 131, 132, 133, 134, 135, 136, 137, 138, 139, 140, 141, 142, 143, 144, 145, 146, 147, 148, 149, 150, 151, 152, 153, 154, 155, 156, 157, 158, 159, 160, 161, 162, 163, 164, 165, 166, 167, 168, 169, 170, 171, 172, 173, 174, 175, 176, 177, 178, 179, 180, 181, 182, 183, 184, 185, 186, 187, 188, 189, 190, 191, 192, 193, 194, 195, 196, 197, 198, 199, 200, 201, 202, 203, 204, 205, 206, 207, 208, 209, 210, 211, 212, 213, 214, 215, 216, 217, 218, 219, 220, 221, 222, 223, 224, 225, 226, 227, 228, 229, 230, 231, 232, 233, 234, 235, 236, 237, 238, 239, 240, 241, 242, 243, 244, 245, 246, 247, 248, 249, 250, 251, 252, 253, 254, 255, 256, 257, 258, 259, 260, 261, 262, 263, 264, 265, 266, 267, 268, 269, 270, 271, 272, 273, 274, 275, 276, 277, 278, 279, 280, 281, 282, 283, 284, 285, 286, 287, 288, 289, 290, 291, 292, 293, 294, 295, 296, 297, 298, 299, 300, 301, 302, 303, 304, 305, 306, 307, 308, 309, 310, 311, 312, 313, 314, 315, 316, 317, 318, 319, 320, 321, 322, 323, 324, 325, 326, 327, 328, 329, 330, 331, 332, 333, 334, 335, 336, 337, 338, 339, 340, 341, 342, 343, 344, 345, 346, 347, 348, 349, 350, 351, 352, 353, 354, 355, 356, 357, 358, 359, 360, 361, 362, 363, 364, 365, 366, 367, 368, 369, 370, 371, 372, 373, 374, 375, 376, 377, 378, 379, 380, 381, 382, 383, 384, 385, 386, 387, 388, 389, 390, 391, 392, 393, 394, 395, 396, 397, 398, 399, 400, 401, 402, 403, 404, 405, 406, 407, 408, 409, 410, 411, 412, 413, 414, 415, 416, 417, 418, 419, 420, 421, 422, 423, 424, 425, 426, 427, 428, 429, 430, 431, 432, 433, 434, 435, 436, 437, 438, 439, 440, 441, 442, 443, 444, 445, 446, 447, 448, 449, 450, 451, 452, 453, 454, 455, 456, 457, 458, 459, 460, 461, 462, 463, 464, 465, 466, 467, 468, 469, 470, 471, 472, 473, 474, 475, 476, 477, 478, 479, 480, 481, 482, 483, 484, 485, 486, 487, 488, 489, 490, 491, 492, 493, 494, 495, 496, 497, 498, 499, 500, 501, 502, 503, 504, 505, 506, 507, 508, 509, 510, 511, 512, 513, 514, 515, 516, 517, 518, 519, 520, 521, 522, 523, 524, 525, 526, 527, 528, 529, 530, 531, 532, 533, 534, 535, 536, 537, 538, 539, 540, 541, 542, 543, 544, 545, 546, 547, 548, 549, 550, 551, 552, 553, 554, 555, 556, 557, 558, 559, 560, 561, 562, 563, 564, 565, 566, 567, 568, 569, 570, 571, 572, 573, 574, 575, 576, 577, 578, 579, 580, 581, 582, 583, 584, 585, 586, 587, 588, 589, 590, 591, 592, 593, 594, 595, 596, 597, 598, 599, 600, 601, 602, 603, 604, 605, 606, 607, 608, 609, 610, 611, 612, 613, 614, 615, 616, 617, 618, 619, 620, 621, 622, 623, 624, 625, 626, 627, 628, 629, 630, 631, 632, 633, 634, 635, 636, 637, 638, 639, 640, 641, 642, 643, 644, 645, 646, 647, 648, 649, 650, 651, 652, 653, 654, 655, 656, 657, 658, 659, 660, 661, 662, 663, 664, 665, 666, 667, 668, 669, 670, 671, 672, 673, 674, 675, 676, 677, 678, 679, 680, 681, 682, 683, 684, 685, 686, 687, 688, 689, 690, 691, 692, 693, 694, 695, 696, 697, 698, 699, 700, 701, 702, 703, 704, 705, 706, 707, 708, 709, 710, 711, 712, 713, 714, 715, 716, 717, 718, 719, 720, 721, 722, 723, 724, 725, 726, 727, 728, 729, 730, 731, 732, 733, 734, 735, 736, 737, 738, 739, 740, 741, 742, 743, 744, 745, 746, 747, 748, 749, 750, 751, 752, 753, 754, 755, 756, 757, 758, 759, 760, 761, 762, 763, 764, 765, 766, 767, 768, 769, 770, 771, 772, 773, 774, 775, 776, 777, 778, 779, 780, 781, 782, 783, 784, 785, 786, 787, 788, 789, 790, 791, 792, 793, 794, 795, 796, 797, 798, 799, 800, 801, 802, 803, 804, 805, 806, 807, 808, 809, 810, 811, 812, 813, 814, 815, 816, 817, 818, 819, 820, 821, 822, 823, 824, 825, 826, 827, 828, 829, 830, 831, 832, 833, 834, 835, 836, 837, 838, 839, 840, 841, 842, 843, 844, 845, 846, 847, 848, 849, 850, 851, 852, 853, 854, 855, 856, 857, 858, 859, 860, 861, 862, 863, 864, 865, 866, 867, 868, 869, 870, 871, 872, 873, 874, 875, 876, 877, 878, 879, 880, 881, 882, 883, 884, 885, 886, 887, 888, 889, 890, 891, 892, 893, 894, 895, 896, 897, 898, 899, 900, 901, 902, 903, 904, 905, 906, 907, 908, 909, 910, 911, 912, 913, 914, 915, 916, 917, 918, 919, 920, 921, 922, 923, 924, 925, 926, 927, 928, 929, 930, 931, 932, 933, 934, 935, 936, 937, 938, 939, 940, 941, 942, 943, 944, 945, 946, 947, 948, 949, 950, 951, 952, 953, 954, 955, 956, 957, 958, 959, 960, 961, 962, 963, 964, 965, 966, 967, 968, 969, 970, 971, 972, 973, 974, 975, 976, 977, 978, 979, 980, 981, 982, 983, 984, 985, 986, 987, 988, 989, 990, 991, 992, 993, 994, 995, 996, 997, 998, 999, 1000

NOTE:  
 FOR ACCURATE RIGHT OF WAY DATA, CONTACT  
 RIGHT OF WAY ENGINEERING AT THE DISTRICT OFFICE.

Dist	COUNTY	ROUTE	POST MILES TOTAL PROJECT	SHEET No.	TOTAL SHEETS
04	Ala, CC	680	R11.0/R21.9, R0.0/R0.9	677	1710

ERIN D. McPHERSON  
 REGISTERED CIVIL ENGINEER  
 DATE: 9-29-21  
 October 8, 2021  
 PLANS APPROVAL DATE

ERIN D. McPHERSON  
 No. C91111  
 Exp. 3-31-24  
 CIVIL  
 STATE OF CALIFORNIA

THE STATE OF CALIFORNIA OR ITS OFFICERS  
 OR AGENTS SHALL NOT BE RESPONSIBLE FOR  
 THE ACCURACY OR COMPLETENESS OF SCANNED  
 COPIES OF THIS PLAN SHEET.

WMH CORPORATION 55 South Market St Suite 1200 San Jose, CA 95113	ALAMEDA CTC 1111 Broadway Suite 800 Oakland, CA 94607
---------------------------------------------------------------------------	----------------------------------------------------------------

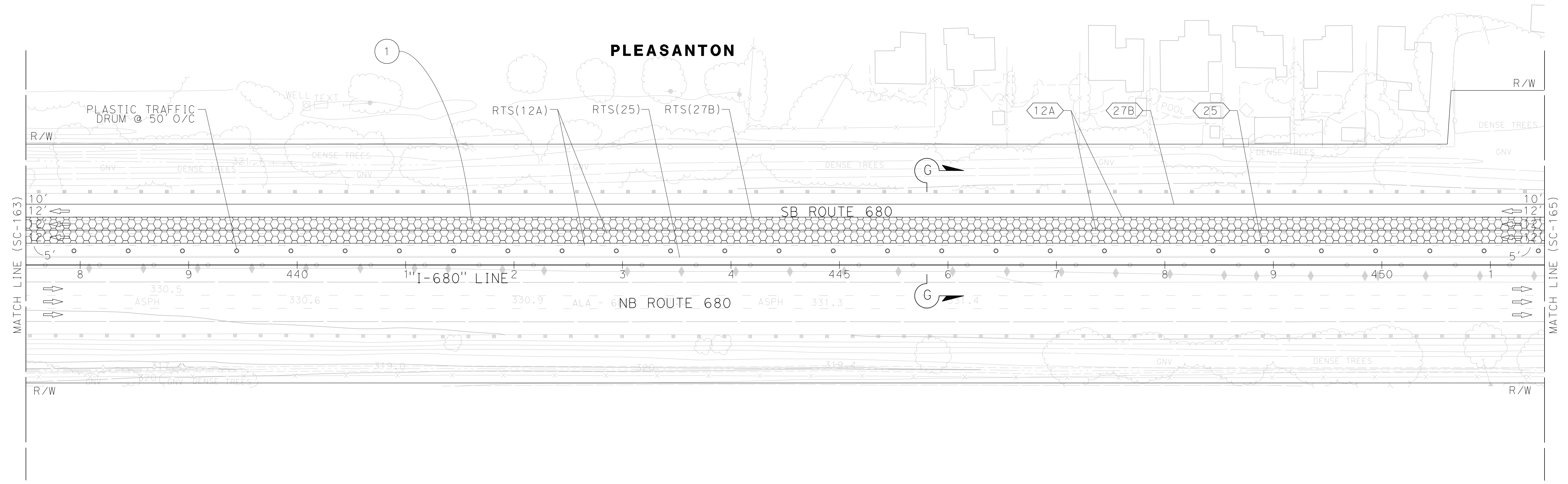
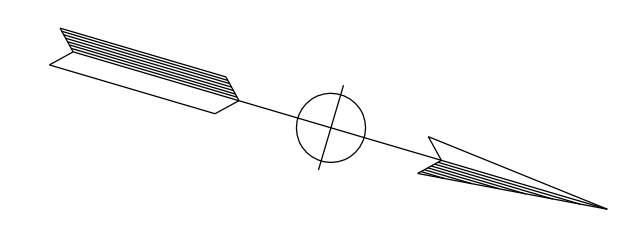

FOR NOTES, ABBREVIATIONS AND  
 LEGEND, SEE SHEET SC-1 AND SC-144

APPROVED FOR STAGE CONSTRUCTION AND TRAFFIC HANDLING WORK ONLY

**STAGE CONSTRUCTION  
 AND TRAFFIC HANDLING PLAN  
 STAGE 3**

SCALE: 1" = 50'

**SC-164**

LAST REVISION: 09-29-21  
 DATE PLOTTED => 3/21/2022  
 TIME PLOTTED => 4:09:53 PM

X:\680\_SB\_EXPRESS\000\_CAD\Submittal\0420000235ma165.dgn  
 STATE OF CALIFORNIA - DEPARTMENT OF TRANSPORTATION  
 CONSULTANT FUNCTIONAL SUPERVISOR  
 JAMEY VALDIVIA  
 ERIN MCPHERSON  
 TIMOTHY J. LEE  
 Calculated-Designed By  
 Checked By  
 Revised By  
 Date Revised  
 JV  
 9-29-21

NOTE:  
 FOR ACCURATE RIGHT OF WAY DATA, CONTACT  
 RIGHT OF WAY ENGINEERING AT THE DISTRICT OFFICE.

Dist	COUNTY	ROUTE	POST MILES TOTAL PROJECT	SHEET No.	TOTAL SHEETS
04	Ala, CC	680	R11.0/R21.9, R0.0/R0.9	678	1710

ERIN D. McPHERSON  
 REGISTERED CIVIL ENGINEER  
 DATE 9-29-21  
 October 8, 2021  
 PLANS APPROVAL DATE  
 No. C91111  
 Exp. 3-31-24  
 CIVIL  
 STATE OF CALIFORNIA

THE STATE OF CALIFORNIA OR ITS OFFICERS  
 OR AGENTS SHALL NOT BE RESPONSIBLE FOR  
 THE ACCURACY OR COMPLETENESS OF SCANNED  
 COPIES OF THIS PLAN SHEET.

WMH CORPORATION 55 South Market St Suite 1200 San Jose, CA 95113	ALAMEDA CTC 1111 Broadway Suite 800 Oakland, CA 94607
---------------------------------------------------------------------------	----------------------------------------------------------------

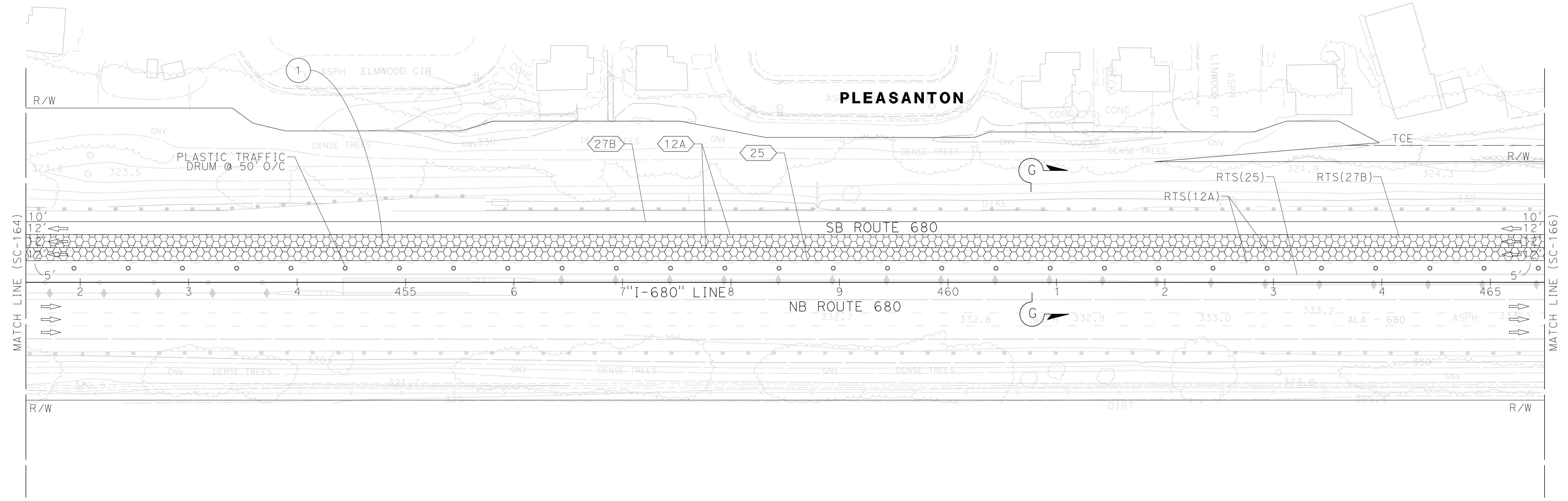
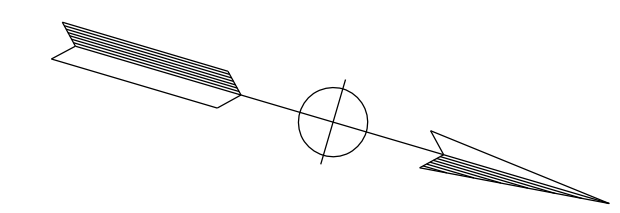

**STAGE CONSTRUCTION  
 AND TRAFFIC HANDLING PLAN  
 STAGE 3**

SCALE: 1" = 50'

**SC-165**

FOR NOTES, ABBREVIATIONS AND  
 LEGEND, SEE SHEET SC-1 AND SC-144

APPROVED FOR STAGE CONSTRUCTION AND TRAFFIC HANDLING WORK ONLY

LAST REVISION DATE PLOTTED => 3/21/2022  
 09-29-21 TIME PLOTTED => 4:09:57 PM

X:\680\_SB\_EXPRESS\000\_CAD\Submittal\0420000235ma166.dgn  
 STATE OF CALIFORNIA - DEPARTMENT OF TRANSPORTATION  
 CONSULTANT FUNCTIONAL SUPERVISOR  
 JAMEY VALDIVIA  
 ERIN MCPHERSON  
 TIMOTHY J. LEE  
 CHECKED BY  
 DESIGNED BY  
 REVISIONS  
 REVISED BY  
 DATE REVISED  
 JV  
 9-29-21

NOTE:  
 FOR ACCURATE RIGHT OF WAY DATA, CONTACT  
 RIGHT OF WAY ENGINEERING AT THE DISTRICT OFFICE.

Dist	COUNTY	ROUTE	POST MILES TOTAL PROJECT	SHEET No.	TOTAL SHEETS
04	Ala, CC	680	R11.0/R21.9, R0.0/R0.9	679	1710

ERIN D. McPHERSON  
 REGISTERED CIVIL ENGINEER  
 DATE 9-29-21  
 October 8, 2021  
 PLANS APPROVAL DATE  
 No. C91111  
 Exp. 3-31-24  
 CIVIL  
 STATE OF CALIFORNIA

THE STATE OF CALIFORNIA OR ITS OFFICERS  
 OR AGENTS SHALL NOT BE RESPONSIBLE FOR  
 THE ACCURACY OR COMPLETENESS OF SCANNED  
 COPIES OF THIS PLAN SHEET.

WMH CORPORATION 55 South Market St Suite 1200 San Jose, CA 95113	ALAMEDA CTC 1111 Broadway Suite 800 Oakland, CA 94607
---------------------------------------------------------------------------	----------------------------------------------------------------

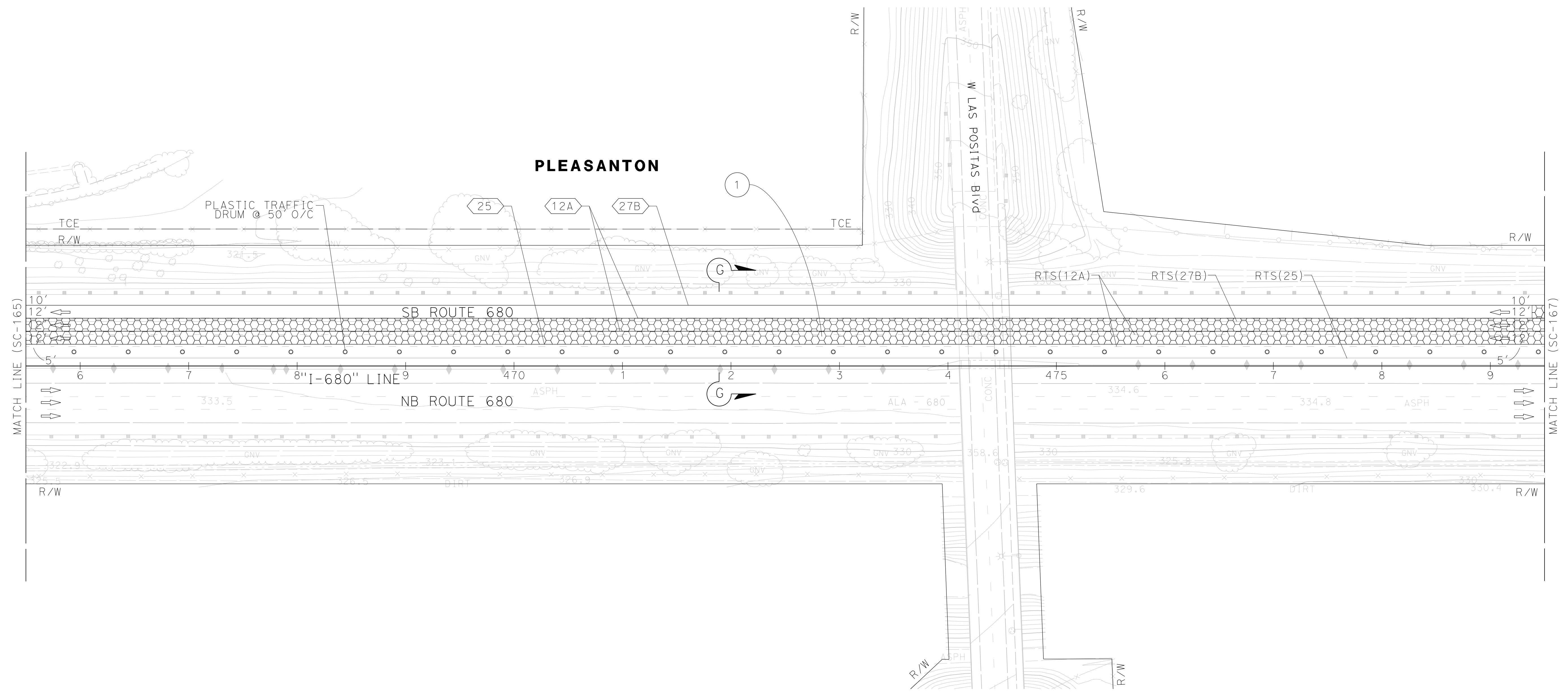
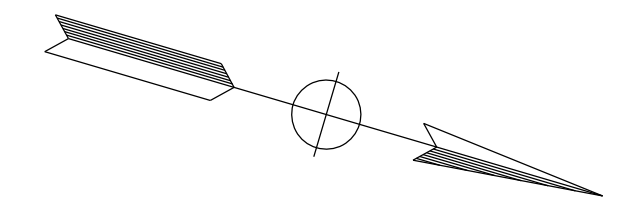

FOR NOTES, ABBREVIATIONS AND  
 LEGEND, SEE SHEET SC-1 AND SC-144

APPROVED FOR STAGE CONSTRUCTION AND TRAFFIC HANDLING WORK ONLY

**STAGE CONSTRUCTION  
 AND TRAFFIC HANDLING PLAN  
 STAGE 3**

SCALE: 1" = 50'

**SC-166**

LAST REVISION  
 DATE PLOTTED => 3/21/2022  
 09-29-21  
 TIME PLOTTED => 4:10:00 PM

X:\680\_SB\_EXPRESS\000\_CAD\Submittal\0420000235ma167.dgn  
 STATE OF CALIFORNIA - DEPARTMENT OF TRANSPORTATION  
**Caltrans**  
 CONSULTANT FUNCTIONAL SUPERVISOR: JIMMY J. LEE  
 CALCULATED/DESIGNED BY: JAMEY VALDIVIA  
 CHECKED BY: ERIN MCPHERSON  
 REVISED BY: J.V.  
 DATE REVISED: 9-29-21

NOTE:  
 FOR ACCURATE RIGHT OF WAY DATA, CONTACT  
 RIGHT OF WAY ENGINEERING AT THE DISTRICT OFFICE.

Dist	COUNTY	ROUTE	POST MILES TOTAL PROJECT	SHEET No.	TOTAL SHEETS
04	Ala, CC	680	R11.0/R21.9, R0.0/R0.9	680	1710

ERIN D. MCPHERSON  
 REGISTERED CIVIL ENGINEER  
 DATE: 9-29-21  
 PLANS APPROVAL DATE: October 8, 2021  
 No. C91111  
 Exp. 3-31-24  
 CIVIL  
 STATE OF CALIFORNIA

WMH CORPORATION  
 55 South Market St  
 Suite 1200  
 San Jose, CA 95113

ALAMEDA CTC  
 1111 Broadway  
 Suite 800  
 Oakland, CA 94607

THE STATE OF CALIFORNIA OR ITS OFFICERS OR AGENTS SHALL NOT BE RESPONSIBLE FOR THE ACCURACY OR COMPLETENESS OF SCANNED COPIES OF THIS PLAN SHEET.

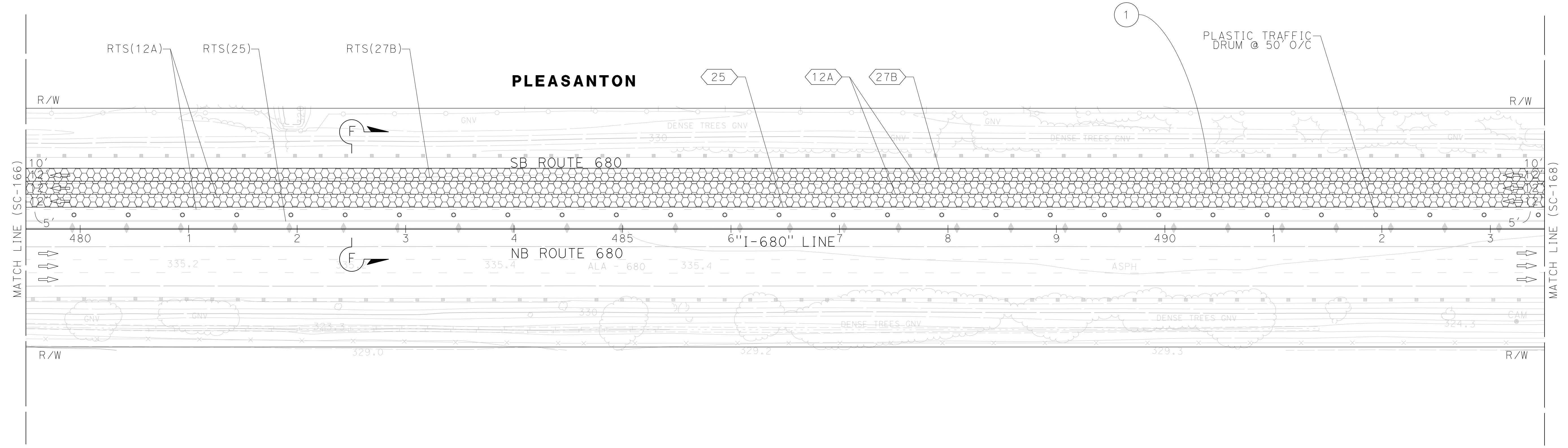
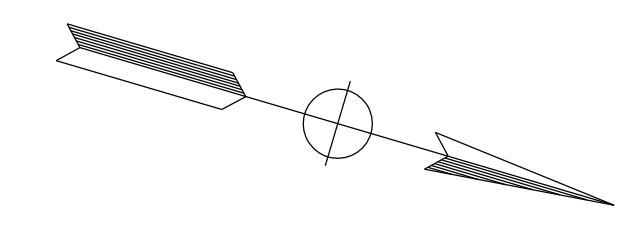

FOR NOTES, ABBREVIATIONS AND  
 LEGEND, SEE SHEET SC-1 AND SC-144

APPROVED FOR STAGE CONSTRUCTION AND TRAFFIC HANDLING WORK ONLY

## STAGE CONSTRUCTION AND TRAFFIC HANDLING PLAN STAGE 3

SCALE: 1" = 50'

**SC-167**

LAST REVISION: 09-29-21    DATE PLOTTED => 3/21/2022    TIME PLOTTED => 4:10:05 PM

X:\680\_SB\_EXPRESS\000\_CAD\Submittal\11\11\CADD\_submittal\0420000235ma168.dgn  
 STATE OF CALIFORNIA - DEPARTMENT OF TRANSPORTATION  
 CONSULTANT FUNCTIONAL SUPERVISOR  
 JAMEY VALDIVIA  
 ERIN MCPHERSON  
 TIMOTHY J. LEE  
 Calculated-Designed By  
 Checked By  
 Revised By  
 Date Revised  
 JV  
 9-29-21

NOTE:  
 FOR ACCURATE RIGHT OF WAY DATA, CONTACT  
 RIGHT OF WAY ENGINEERING AT THE DISTRICT OFFICE.

Dist	COUNTY	ROUTE	POST MILES TOTAL PROJECT	SHEET No.	TOTAL SHEETS
04	Ala, CC	680	R11.0/R21.9, R0.0/R0.9	681	1710

ERIN D. McPHERSON  
 REGISTERED CIVIL ENGINEER  
 DATE 9-29-21  
 October 8, 2021  
 PLANS APPROVAL DATE  
 No. C91111  
 Exp. 3-31-24  
 CIVIL  
 STATE OF CALIFORNIA

THE STATE OF CALIFORNIA OR ITS OFFICERS  
 OR AGENTS SHALL NOT BE RESPONSIBLE FOR  
 THE ACCURACY OR COMPLETENESS OF SCANNED  
 COPIES OF THIS PLAN SHEET.

WMH CORPORATION 55 South Market St Suite 1200 San Jose, CA 95113	ALAMEDA CTC 1111 Broadway Suite 800 Oakland, CA 94607
---------------------------------------------------------------------------	----------------------------------------------------------------

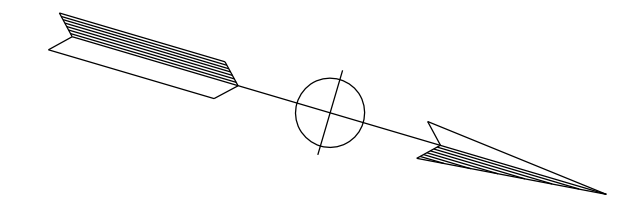

**PLEASANTON**

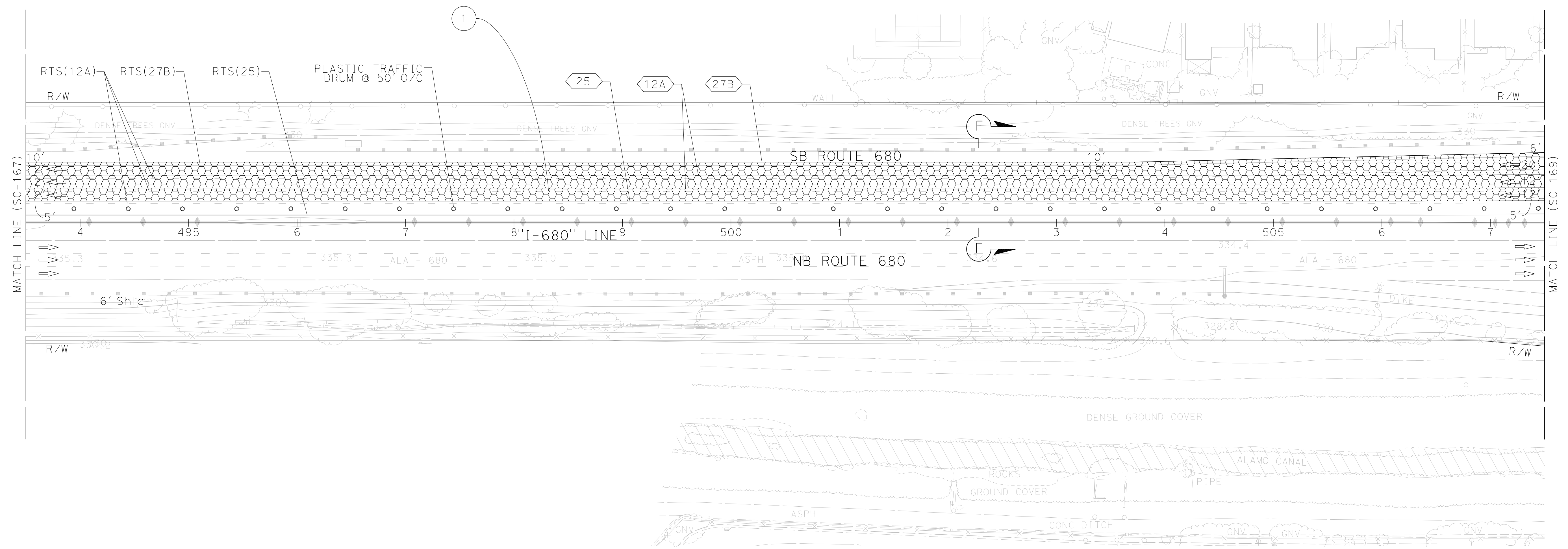

FOR NOTES, ABBREVIATIONS AND  
 LEGEND, SEE SHEET SC-1 AND SC-144

APPROVED FOR STAGE CONSTRUCTION AND TRAFFIC HANDLING WORK ONLY

**STAGE CONSTRUCTION  
 AND TRAFFIC HANDLING PLAN  
 STAGE 3**

SCALE: 1" = 50'

**SC-168**

LAST REVISION DATE PLOTTED => 3/21/2022  
 09-29-21 TIME PLOTTED => 4:10:09 PM

Dist	COUNTY	ROUTE	POST MILES TOTAL PROJECT	SHEET No.	TOTAL SHEETS
04	Ala, CC	680	R11.0/R21.9, RO.0/RO.9	682	1710
			9-29-21		
REGISTERED CIVIL ENGINEER			DATE		
October 8, 2021			PLANS APPROVAL DATE		
THE STATE OF CALIFORNIA OR ITS OFFICERS OR AGENTS SHALL NOT BE RESPONSIBLE FOR THE ACCURACY OR COMPLETENESS OF SCANNED COPIES OF THIS PLAN SHEET.					
WMH CORPORATION 55 South Market St Suite 1200 San Jose, CA 95113			ALAMEDA CTC 1111 Broadway Suite 800 Oakland, CA 94607		

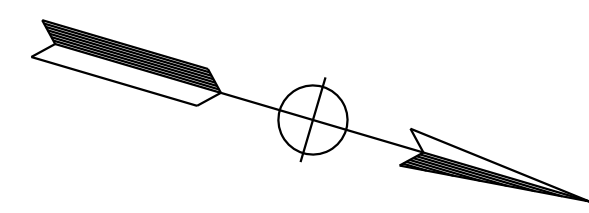

NOTE:  
FOR ACCURATE RIGHT OF WAY DATA, CONTACT  
RIGHT OF WAY ENGINEERING AT THE DISTRICT OFFICE.

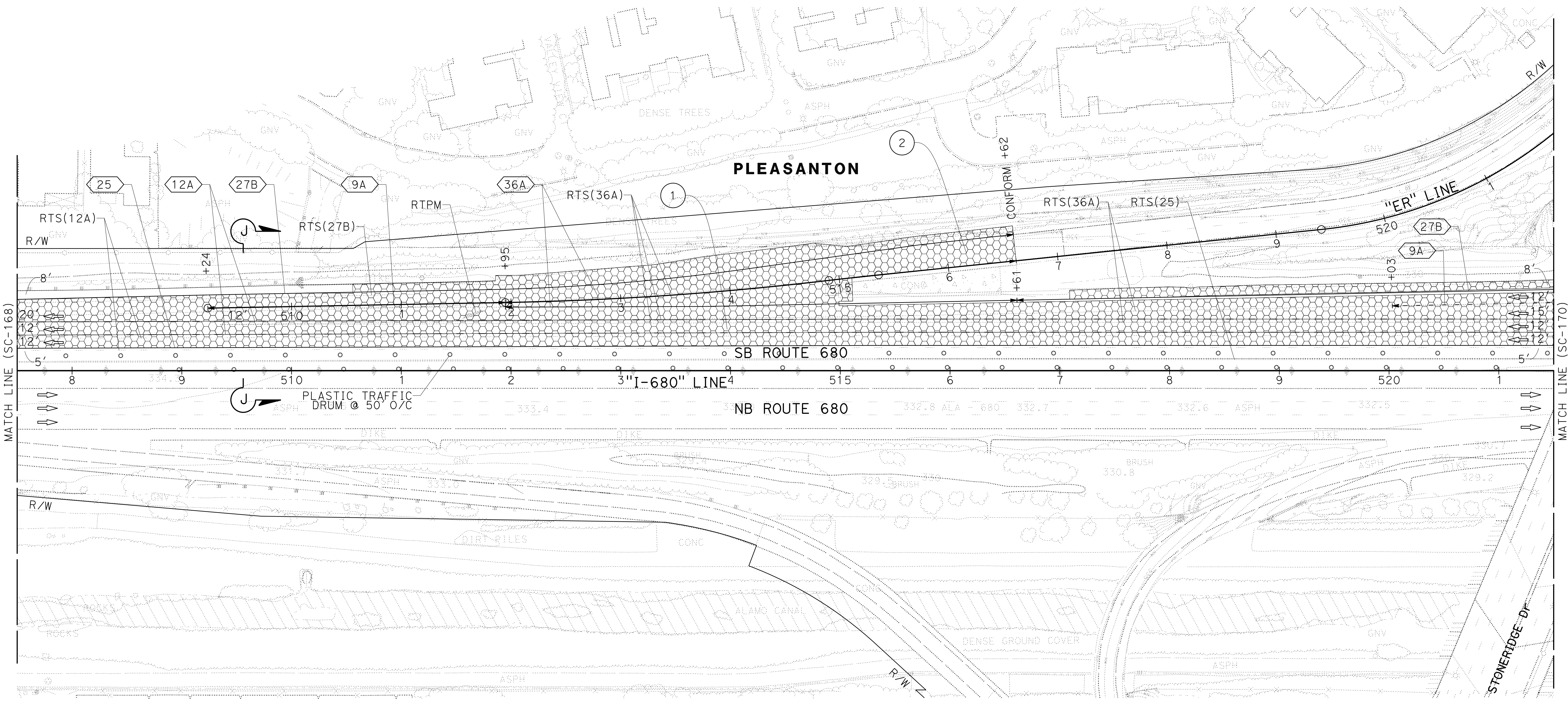

# STAGE CONSTRUCTION AND TRAFFIC HANDLING PLAN STAGE 3

SCALE: 1" = 50'

**SC-169**

FOR NOTES, ABBREVIATIONS AND  
LEGEND, SEE SHEET SC-1 AND SC-144

APPROVED FOR STAGE CONSTRUCTION AND TRAFFIC HANDLING WORK ONLY

DESIGNED BY	JAMEY VALDIVIA
CHECKED BY	ERIN MCPHERSON
CALCULATED/DESIGNED BY	
CONSULTANT FUNCTIONAL SUPERVISOR	TIMOTHY J. LEE
REVISOR	JV
DATE	9-29-21

LAST REVISION: DATE PLOTTED => 8-MAR-2022    TIME PLOTTED => 10:12

Dist	COUNTY	ROUTE	POST MILES TOTAL PROJECT	SHEET No.	TOTAL SHEETS
04	Ala, CC	680	R11.0/R21.9, RO.0/RO.9	683	1710
			9-29-21		
REGISTERED CIVIL ENGINEER			DATE		
			October 8, 2021		
			PLANS APPROVAL DATE		
<small>THE STATE OF CALIFORNIA OR ITS OFFICERS OR AGENTS SHALL NOT BE RESPONSIBLE FOR THE ACCURACY OR COMPLETENESS OF SCANNED COPIES OF THIS PLAN SHEET.</small>					
WMH CORPORATION 55 South Market St Suite 1200 San Jose, CA 95113			ALAMEDA CTC 1111 Broadway Suite 800 Oakland, CA 94607		



NOTE:  
FOR ACCURATE RIGHT OF WAY DATA, CONTACT  
RIGHT OF WAY ENGINEERING AT THE DISTRICT OFFICE.

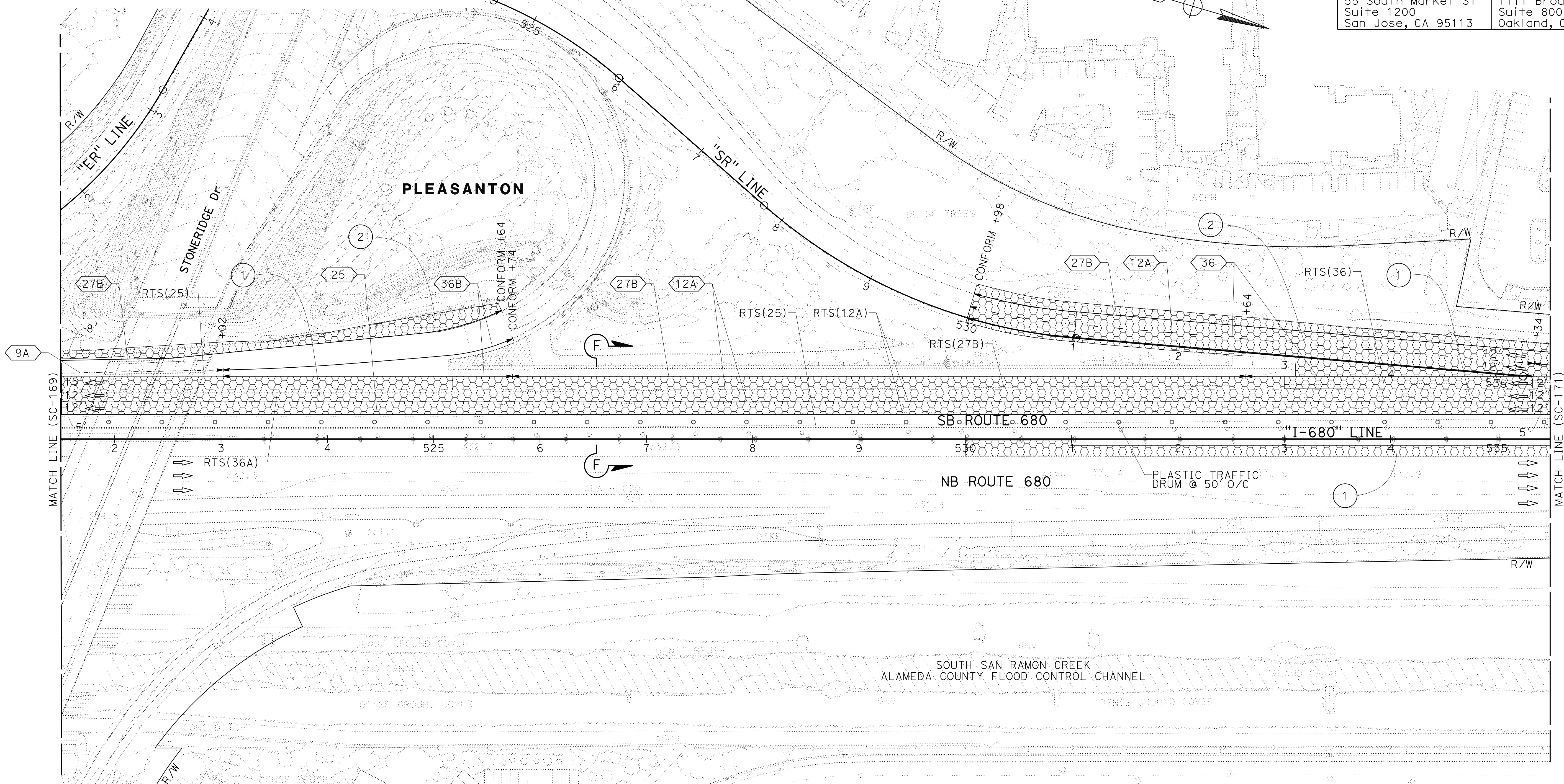

## STAGE CONSTRUCTION AND TRAFFIC HANDLING PLAN STAGE 3

SCALE: 1" = 50'

**SC-170**

APPROVED FOR STAGE CONSTRUCTION AND TRAFFIC HANDLING WORK ONLY

FOR NOTES, ABBREVIATIONS AND  
LEGEND, SEE SHEET SC-1 AND SC-144

STATE OF CALIFORNIA - DEPARTMENT OF TRANSPORTATION	CONSULTANT	FUNCTIONAL SUPERVISOR	CALCULATED-DESIGNED BY	REVISOR	DATE
	JAMEY VALDIVIA	TIMOTHY J. LEE	ERIN MCPHERSON	JV	9-29-21
	ERIN MCPHERSON				

O:\00300\DRAWING\FINAL\_P58E\0420000235ma171.dgn  
 STATE OF CALIFORNIA - DEPARTMENT OF TRANSPORTATION  
 Erwin  
 JAMES VALDIVIA  
 ERIN MCPHERSON  
 TIMOTHY J. LEE

NOTE:  
 FOR ACCURATE RIGHT OF WAY DATA, CONTACT  
 RIGHT OF WAY ENGINEERING AT THE DISTRICT OFFICE.

Dist	COUNTY	ROUTE	POST MILES TOTAL PROJECT	SHEET No.	TOTAL SHEETS
04	Ala, CC	680	R11.0/R21.9, RO.0/RO.9	684	1710
			9-29-21		
REGISTERED CIVIL ENGINEER			DATE		
October 8, 2021			PLANS APPROVAL DATE		
WMH CORPORATION 55 South Market St Suite 1200 San Jose, CA 95113			ALAMEDA CTC 1111 Broadway Suite 800 Oakland, CA 94607		

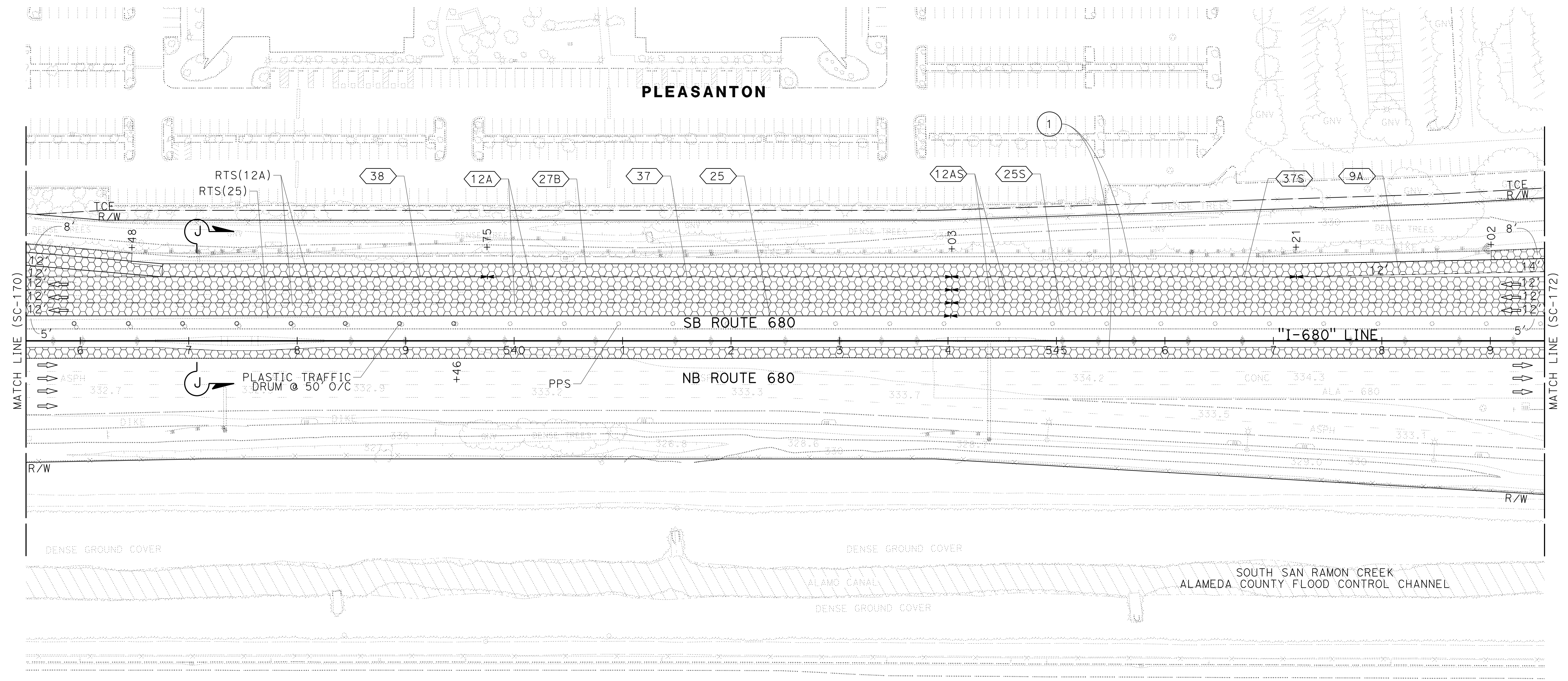
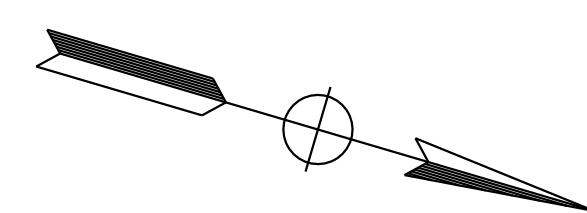

FOR NOTES, ABBREVIATIONS AND  
 LEGEND, SEE SHEET SC-1 AND SC-144

APPROVED FOR STAGE CONSTRUCTION AND TRAFFIC HANDLING WORK ONLY

## STAGE CONSTRUCTION AND TRAFFIC HANDLING PLAN STAGE 3

SCALE: 1" = 50'

SC-171

LAST REVISION DATE PLOTTED => 8-MAR-2022  
 09-29-21 TIME PLOTTED => 10:12

0:\0030\UDRAFTING\FINAL\_P58E\0420000235m172.dgn  
 STATE OF CALIFORNIA - DEPARTMENT OF TRANSPORTATION  
 Et Caltrans®  
 CONSULTANT: FUNCTIONAL SUPERVISOR: TIMOTHY J. LEE  
 CALCULATED/DESIGNED BY: CHECKED BY:  
 JAMEY VALDIVIA ERIN MCPHERSON  
 REVISED BY: DATE REVISED: 9-29-21  
 JV

NOTE:  
 FOR ACCURATE RIGHT OF WAY DATA, CONTACT  
 RIGHT OF WAY ENGINEERING AT THE DISTRICT OFFICE.

Dist	COUNTY	ROUTE	POST MILES TOTAL PROJECT	SHEET No.	TOTAL SHEETS
04	Ala, CC	680	R11.0/R21.9, RO.0/RO.9	685	1710

Erin D. McPherson  
 REGISTERED CIVIL ENGINEER 9-29-21  
 DATE

October 8, 2021  
 PLANS APPROVAL DATE

ERIN D. MCPHERSON  
 No. C91111  
 Exp. 3-31-24  
 CIVIL  
 STATE OF CALIFORNIA

WMH CORPORATION  
 55 South Market St  
 Suite 1200  
 San Jose, CA 95113

ALAMEDA CTC  
 1111 Broadway  
 Suite 800  
 Oakland, CA 94607

THE STATE OF CALIFORNIA OR ITS OFFICERS OR AGENTS SHALL NOT BE RESPONSIBLE FOR THE ACCURACY OR COMPLETENESS OF SCANNED COPIES OF THIS PLAN SHEET.

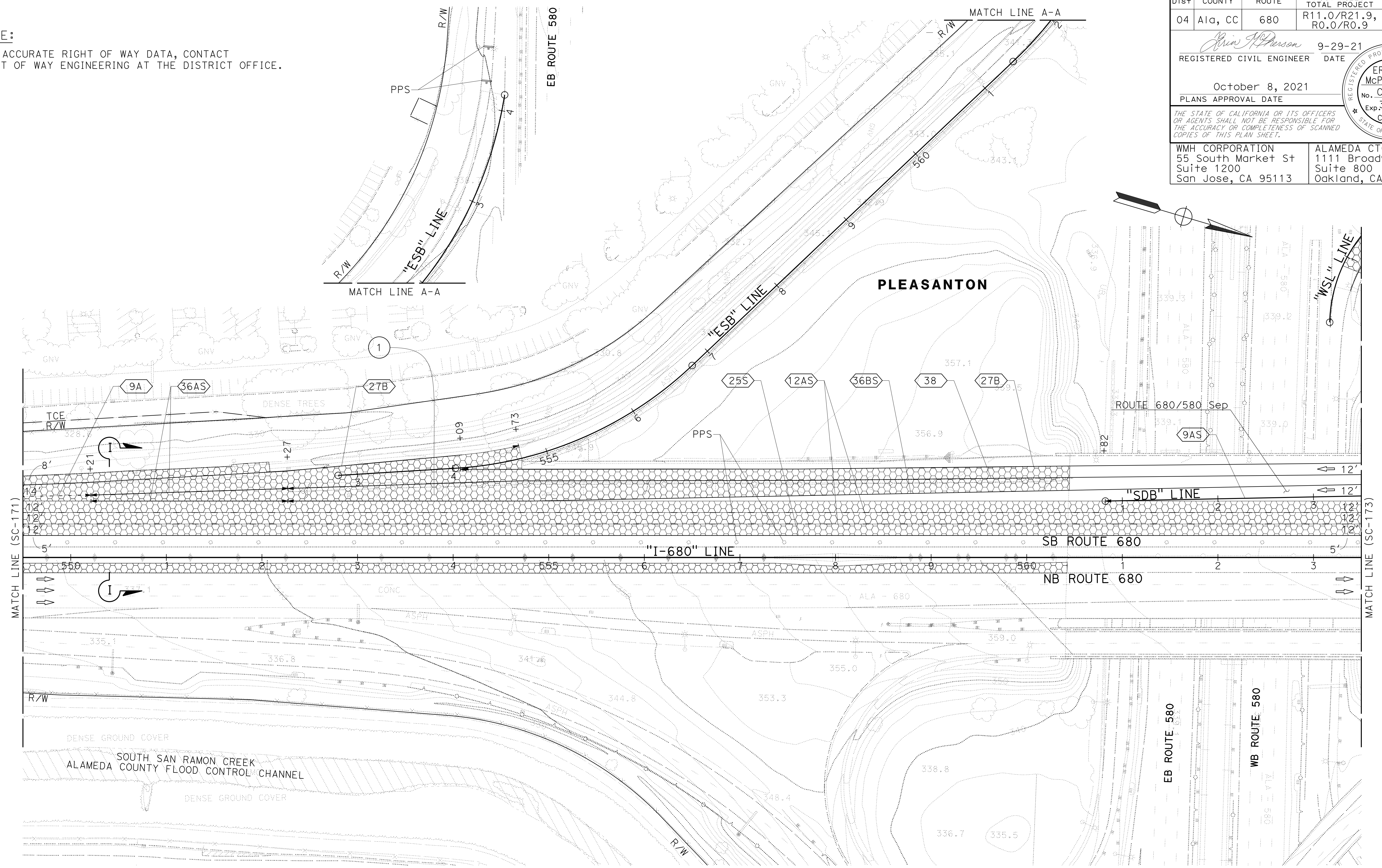

**STAGE CONSTRUCTION  
 AND TRAFFIC HANDLING PLAN  
 STAGE 3**

SCALE: 1" = 50'

**SC-172**

FOR NOTES, ABBREVIATIONS AND  
 LEGEND, SEE SHEET SC-1 AND SC-144

APPROVED FOR STAGE CONSTRUCTION AND TRAFFIC HANDLING WORK ONLY

X:\680\_SB\_EXPRESS\000\_CAD\Submittal\0420000235ma173.dgn  
 STATE OF CALIFORNIA - DEPARTMENT OF TRANSPORTATION  
 CONSULTANT FUNCTIONAL SUPERVISOR: TIMOTHY J. LEE  
 CALCULATED/DESIGNED BY: JAMEY VALDIVIA  
 CHECKED BY: ERIN MCPHERSON  
 REVISED BY: J.V.  
 DATE REVISED: 9-29-21  
 ErCaltans®

**NOTES:**  
 1. FOR ACCURATE RIGHT OF WAY DATA, CONTACT RIGHT OF WAY ENGINEERING AT THE DISTRICT OFFICE.  
 2. PLACE FINAL PAVEMENT DELINEATION FOR RAMP, AFTER WIDENING AND OVERLAY COMPLETION. FOR DETAILS SEE PD SHEETS

Dist	COUNTY	ROUTE	POST MILES TOTAL PROJECT	SHEET No.	TOTAL SHEETS
04	Ala, CC	680	R11.0/R21.9, RO.0/RO.9	686	1710
			9-29-21		
			DATE		
			October 8, 2021		
			PLANS APPROVAL DATE		
<small>THE STATE OF CALIFORNIA OR ITS OFFICERS OR AGENTS SHALL NOT BE RESPONSIBLE FOR THE ACCURACY OR COMPLETENESS OF SCANNED COPIES OF THIS PLAN SHEET.</small>					
WMH CORPORATION 55 South Market St Suite 1200 San Jose, CA 95113			ALAMEDA CTC 1111 Broadway Suite 800 Oakland, CA 94607		

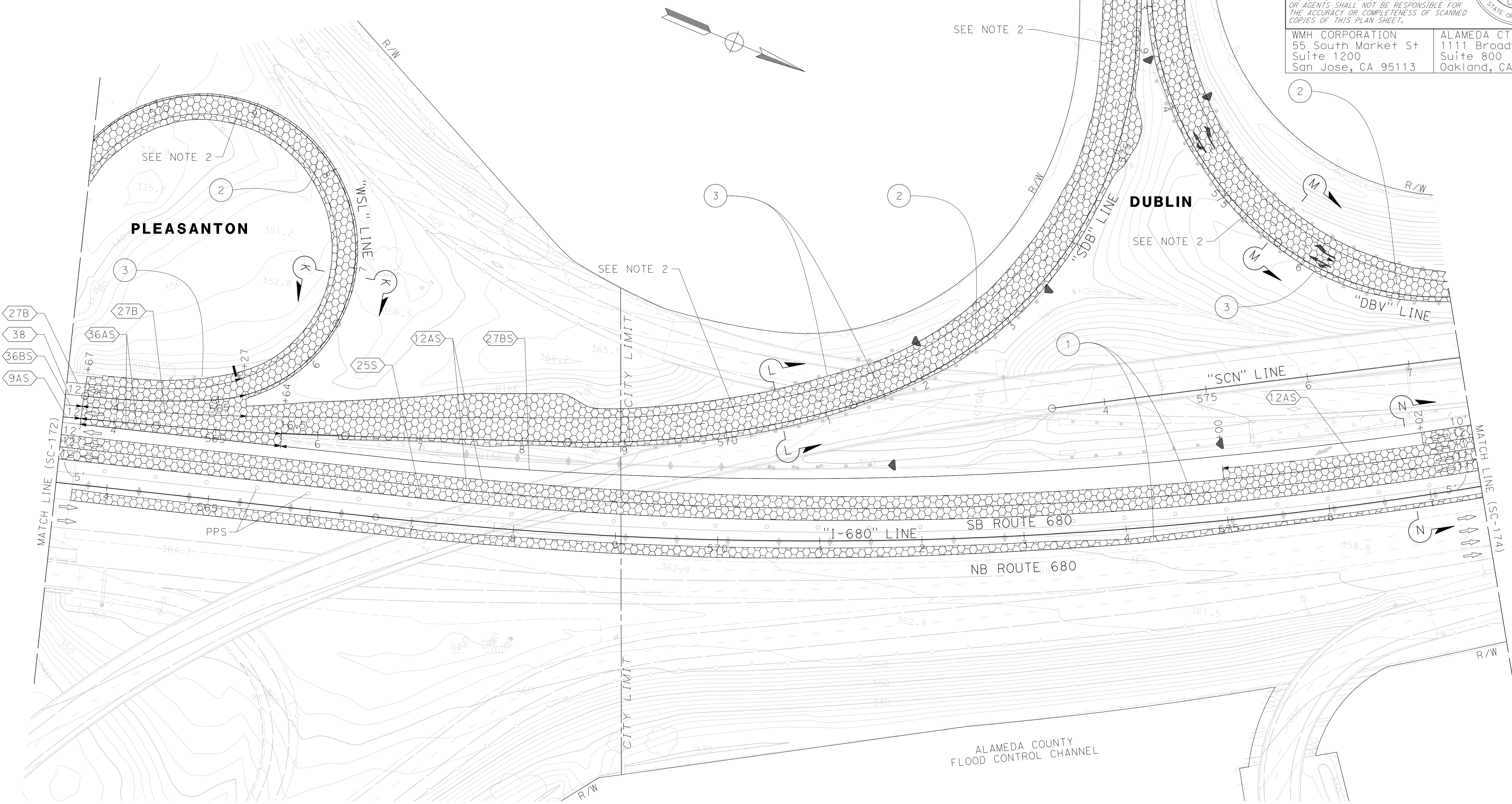
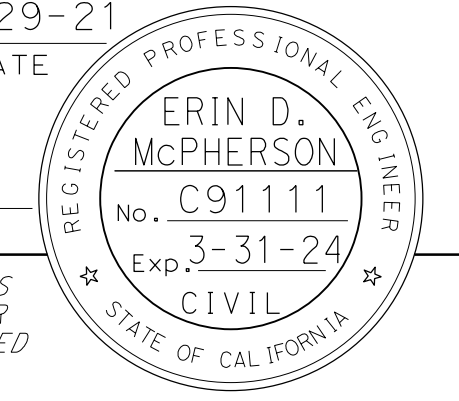

FOR NOTES, ABBREVIATIONS AND LEGEND, SEE SHEET SC-1 AND SC-144

APPROVED FOR STAGE CONSTRUCTION AND TRAFFIC HANDLING WORK ONLY

**STAGE CONSTRUCTION AND TRAFFIC HANDLING PLAN  
 STAGE 3**

SCALE: 1" = 50'

**SC-173**

Dist	COUNTY	ROUTE	POST MILES TOTAL PROJECT	SHEET No.	TOTAL SHEETS
04	Ala, CC	680	R11.0/R21.9, RO.0/RO.9	687	1710
			9-29-21		
REGISTERED CIVIL ENGINEER			DATE		
October 8, 2021			PLANS APPROVAL DATE		
WMH CORPORATION 55 South Market St Suite 1200 San Jose, CA 95113			ALAMEDA CTC 1111 Broadway Suite 800 Oakland, CA 94607		

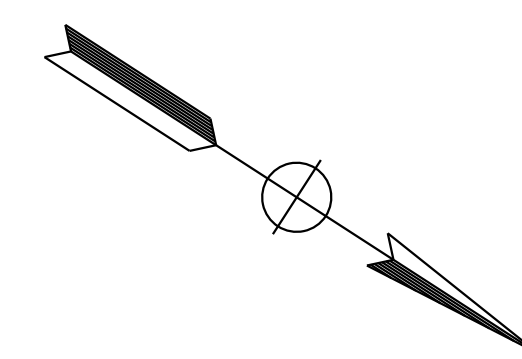

NOTE:  
FOR ACCURATE RIGHT OF WAY DATA, CONTACT  
RIGHT OF WAY ENGINEERING AT THE DISTRICT OFFICE.

DESIGNED BY	JAMEY VALDIVIA
CHECKED BY	ERIN MCPHERSON
REVISIONS	
DATE	9-29-21
BY	JV
REVISIONS	
DATE	
BY	
DESIGNED BY	TIMOTHY J. LEE
CHECKED BY	
REVISIONS	
DATE	
BY	
DESIGNED BY	
CHECKED BY	
REVISIONS	
DATE	
BY	

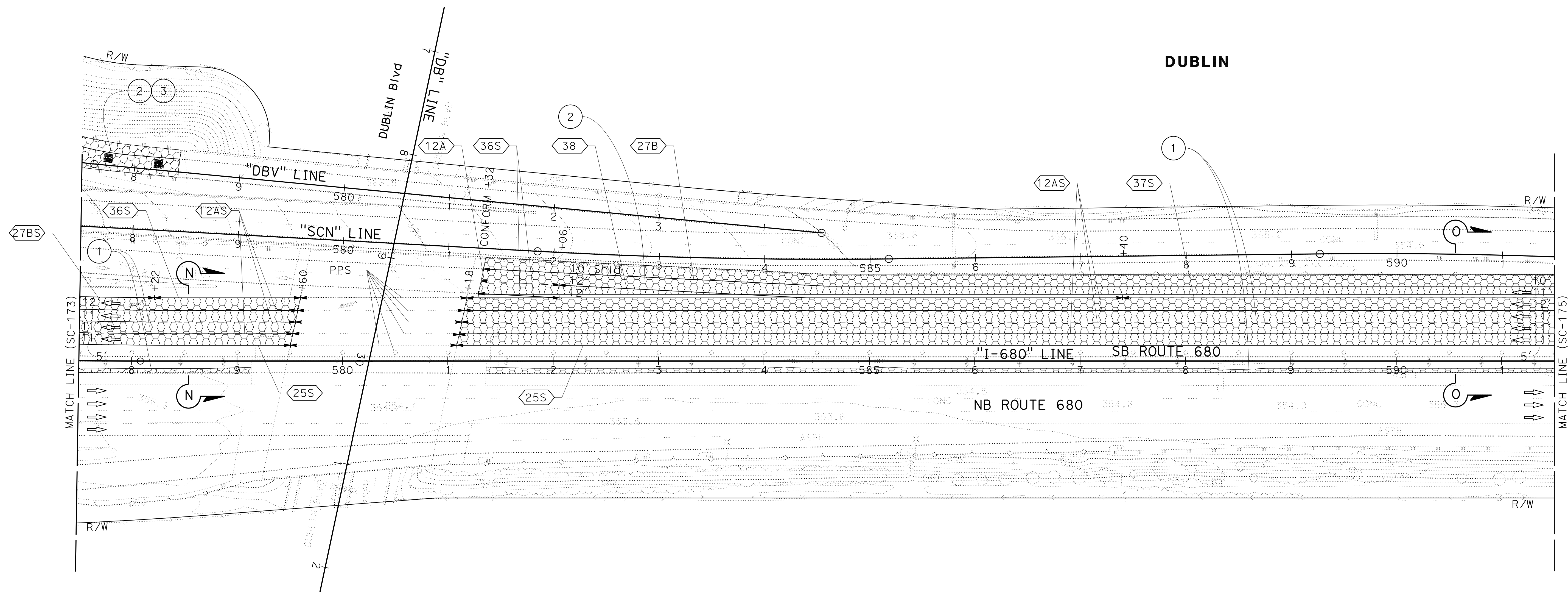

## STAGE CONSTRUCTION AND TRAFFIC HANDLING PLAN STAGE 3

SCALE: 1" = 50'

**SC-174**

FOR NOTES, ABBREVIATIONS AND  
LEGEND, SEE SHEET SC-1 AND SC-144

APPROVED FOR STAGE CONSTRUCTION AND TRAFFIC HANDLING WORK ONLY

0:\00300\DRAWING\FINAL\_P5&E\0420000235ma174.dgn

LAST REVISION: DATE PLOTTED => 8-MAR-2022  
09-29-21 TIME PLOTTED => 10:13

X:\680\_SB\_EXPRESS\000\_CAD\Submittal\0420000235ma175.dgn  
 STATE OF CALIFORNIA - DEPARTMENT OF TRANSPORTATION  
 CONSULTANT FUNCTIONAL SUPERVISOR: TIMOTHY J. LEE  
 CALCULATED/DESIGNED BY: JAMEY VALDIVIA  
 CHECKED BY: ERIN MCPHERSON  
 REVISED BY: JV  
 DATE REVISED: 9-29-21

NOTE:  
 FOR ACCURATE RIGHT OF WAY DATA, CONTACT  
 RIGHT OF WAY ENGINEERING AT THE DISTRICT OFFICE.

Dist	COUNTY	ROUTE	POST MILES TOTAL PROJECT	SHEET No.	TOTAL SHEETS
04	Ala, CC	680	R11.0/R21.9, R0.0/R0.9	688	1710

REGISTERED CIVIL ENGINEER: *Erin D. McPherson* 9-29-21  
 DATE: 9-29-21  
 PLANS APPROVAL DATE: October 8, 2021

ERIN D. MCPHERSON  
 No. C91111  
 Exp. 3-31-24  
 CIVIL  
 STATE OF CALIFORNIA

THE STATE OF CALIFORNIA OR ITS OFFICERS  
 OR AGENTS SHALL NOT BE RESPONSIBLE FOR  
 THE ACCURACY OR COMPLETENESS OF SCANNED  
 COPIES OF THIS PLAN SHEET.

WMH CORPORATION  
 55 South Market St  
 Suite 1200  
 San Jose, CA 95113

ALAMEDA CTC  
 1111 Broadway  
 Suite 800  
 Oakland, CA 94607

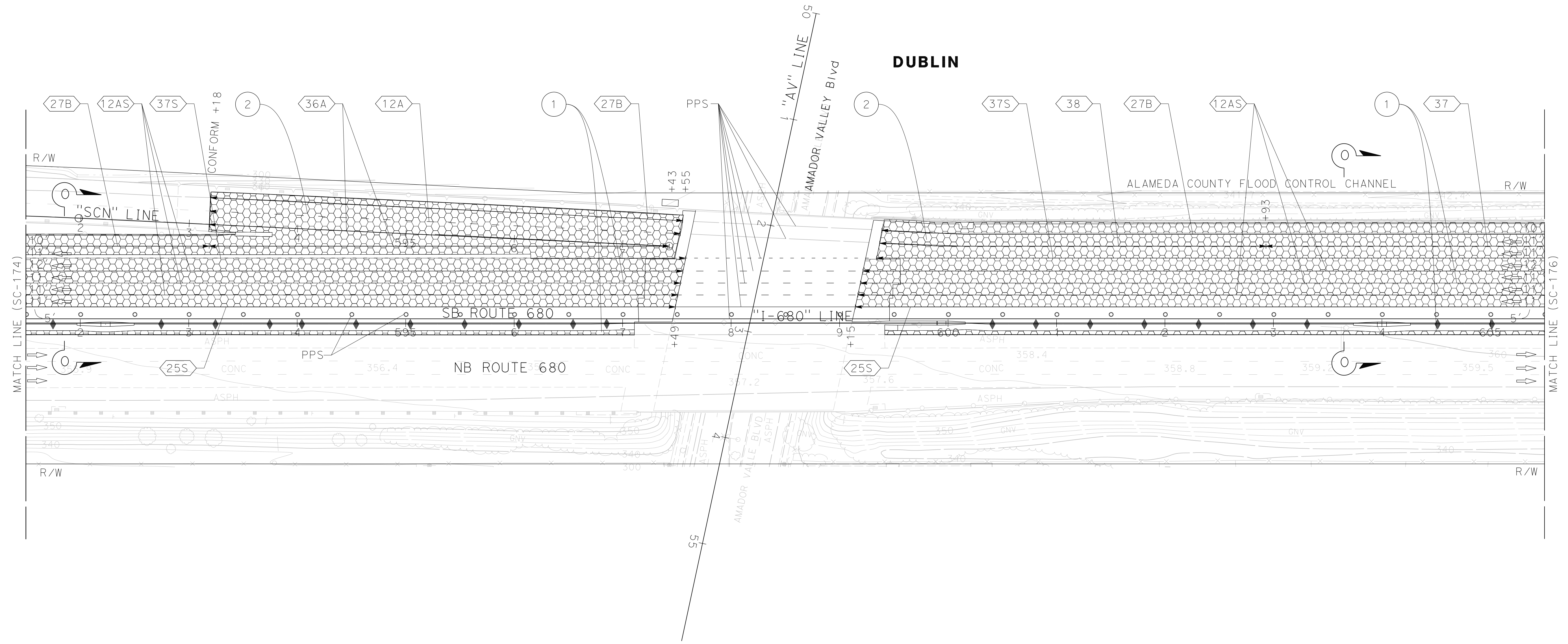
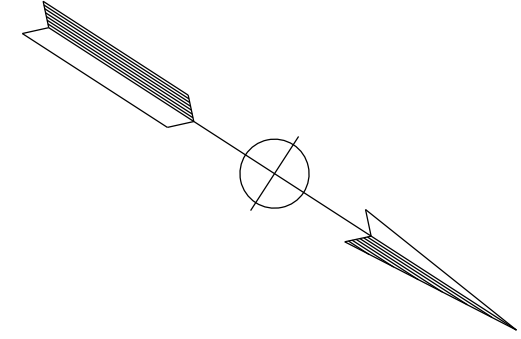

FOR NOTES, ABBREVIATIONS AND  
 LEGEND, SEE SHEET SC-1 AND SC-144

APPROVED FOR STAGE CONSTRUCTION AND TRAFFIC HANDLING WORK ONLY

**STAGE CONSTRUCTION  
 AND TRAFFIC HANDLING PLAN  
 STAGE 3**

SCALE: 1" = 50'

**SC-175**

LAST REVISION: DATE PLOTTED => 3/18/2022  
 09-29-21 TIME PLOTTED => 4:40:12 PM

STATE OF CALIFORNIA - DEPARTMENT OF TRANSPORTATION  
 Et Caltrans®  
 CONSULTANT: FUNCTIONAL SUPERVISOR: JAMEY VALDIVIA  
 CHECKED BY: ERIN McPHERSON  
 DESIGNED BY: ERIN McPHERSON  
 SUPERVISOR: TIMOTHY J. LEE  
 REVISIONS:  
 9-29-21 JV  
 9-29-21

NOTE:  
 FOR ACCURATE RIGHT OF WAY DATA, CONTACT  
 RIGHT OF WAY ENGINEERING AT THE DISTRICT OFFICE.

Dist	COUNTY	ROUTE	POST MILES TOTAL PROJECT	SHEET No.	TOTAL SHEETS
04	Ala, CC	680	R11.0/R21.9, R0.0/R0.9	689	1710

ERIN D. McPHERSON  
 REGISTERED CIVIL ENGINEER  
 No. C91111  
 Exp. 3-31-24  
 CIVIL  
 STATE OF CALIFORNIA

9-29-21  
 DATE  
 REGISTERED CIVIL ENGINEER

October 8, 2021  
 PLANS APPROVAL DATE

THE STATE OF CALIFORNIA OR ITS OFFICERS OR AGENTS SHALL NOT BE RESPONSIBLE FOR THE ACCURACY OR COMPLETENESS OF SCANNED COPIES OF THIS PLAN SHEET.

WMH CORPORATION  
 55 South Market St  
 Suite 1200  
 San Jose, CA 95113

ALAMEDA CTC  
 1111 Broadway  
 Suite 800  
 Oakland, CA 94607

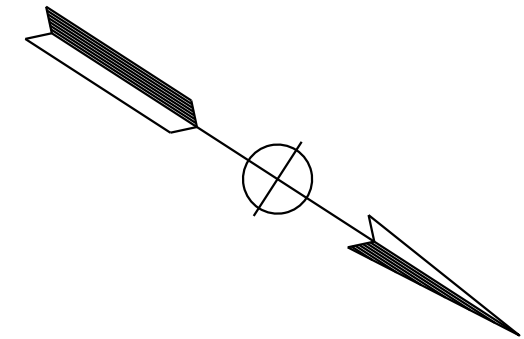

DUBLIN

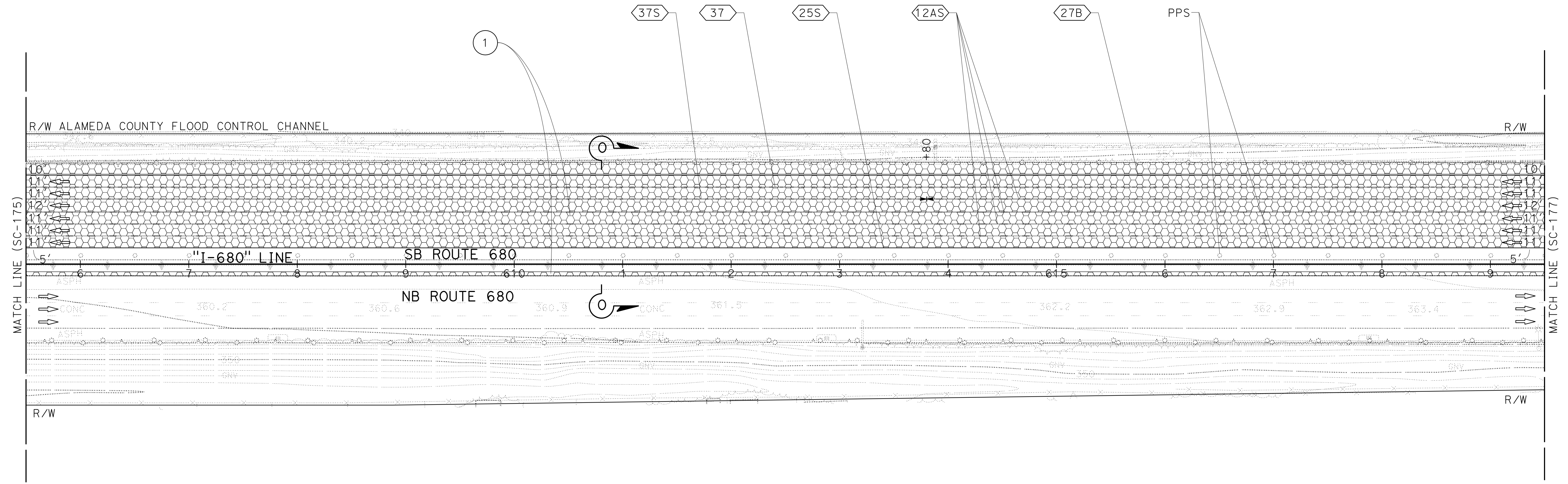

FOR NOTES, ABBREVIATIONS AND LEGEND, SEE SHEET SC-1 AND SC-144

APPROVED FOR STAGE CONSTRUCTION AND TRAFFIC HANDLING WORK ONLY

STAGE CONSTRUCTION AND TRAFFIC HANDLING PLAN  
 STAGE 3

SCALE: 1" = 50'

SC-176

LAST REVISION: 09-29-21  
 DATE PLOTTED => 8-MAR-2022  
 TIME PLOTTED => 10:13

Dist	COUNTY	ROUTE	POST MILES TOTAL PROJECT	SHEET No.	TOTAL SHEETS
04	Ala, CC	680	R11.0/R21.9, RO.0/RO.9	690	1710
			9-29-21		
REGISTERED CIVIL ENGINEER			DATE		
October 8, 2021			PLANS APPROVAL DATE		
WMH CORPORATION 55 South Market St Suite 1200 San Jose, CA 95113			ALAMEDA CTC 1111 Broadway Suite 800 Oakland, CA 94607		

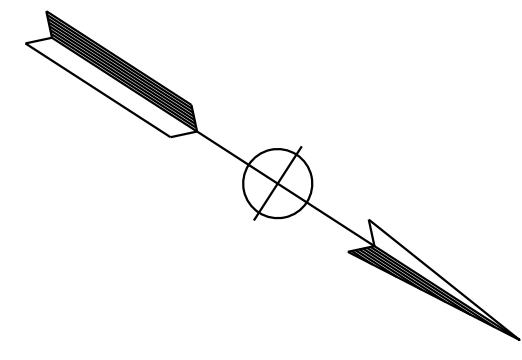

NOTE:  
FOR ACCURATE RIGHT OF WAY DATA, CONTACT  
RIGHT OF WAY ENGINEERING AT THE DISTRICT OFFICE.

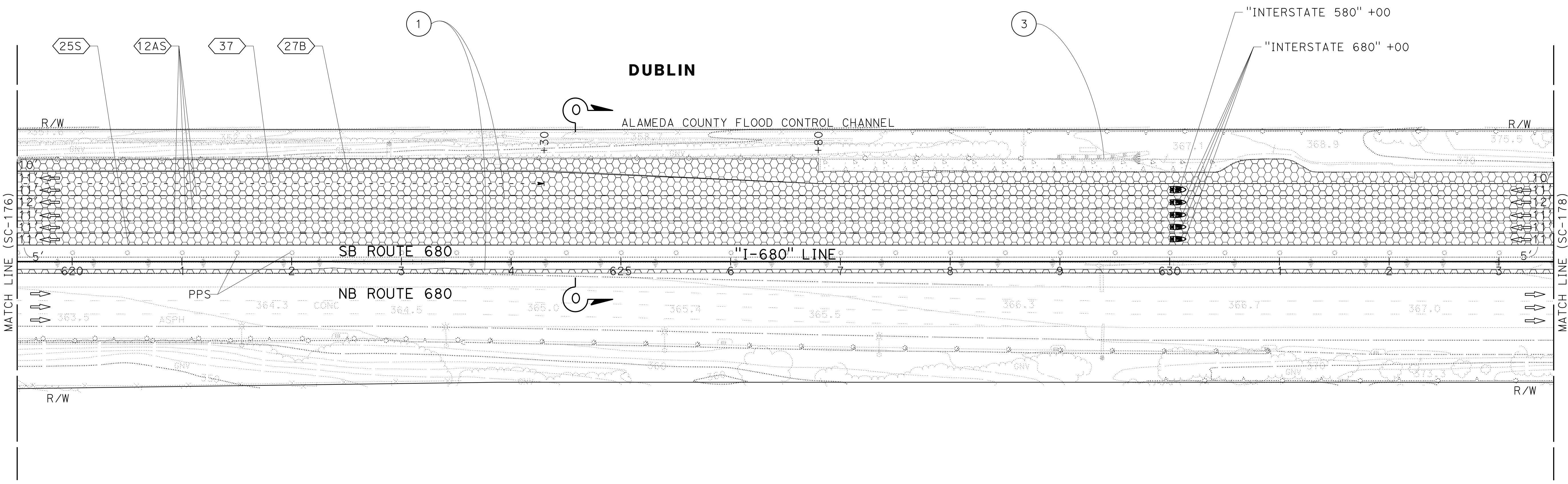

## STAGE CONSTRUCTION AND TRAFFIC HANDLING PLAN STAGE 3

SCALE: 1" = 50'

**SC-177**

FOR NOTES, ABBREVIATIONS AND  
LEGEND, SEE SHEET SC-1 AND SC-144

APPROVED FOR STAGE CONSTRUCTION AND TRAFFIC HANDLING WORK ONLY

O:\00300\DRAWING\FINAL\_P5&E\0420000235ma177.dgn  
 STATE OF CALIFORNIA - DEPARTMENT OF TRANSPORTATION  
 Et Caltrans®  
 CONSULTANT: FUNCTIONAL SUPERVISOR: JAMES VALDIVIA  
 CHECKED BY: ERIN MCPHERSON  
 REVISIONS: REVISED BY: JAMES VALDIVIA, DATE: 9-29-21  
 DESIGNED BY: ERIN MCPHERSON  
 SUPERVISOR: TIMOTHY J. LEE  
 USERNAME => p302438  
 DGN FILE => 0420000235ma177.dgn

Dist	COUNTY	ROUTE	POST MILES TOTAL PROJECT	SHEET No.	TOTAL SHEETS
04	Ala, CC	680	R11.0/R21.9, R0.0/R0.9	691	1710

<i>Erin D. McPherson</i>	9-29-21
REGISTERED CIVIL ENGINEER	DATE

October 8, 2021
PLANS APPROVAL DATE

ERIN D. McPHERSON No. C91111 Exp. 3-31-24 CIVIL STATE OF CALIFORNIA
------------------------------------------------------------------------------------

WMH CORPORATION 55 South Market St Suite 1200 San Jose, CA 95113	ALAMEDA CTC 1111 Broadway Suite 800 Oakland, CA 94607
---------------------------------------------------------------------------	----------------------------------------------------------------

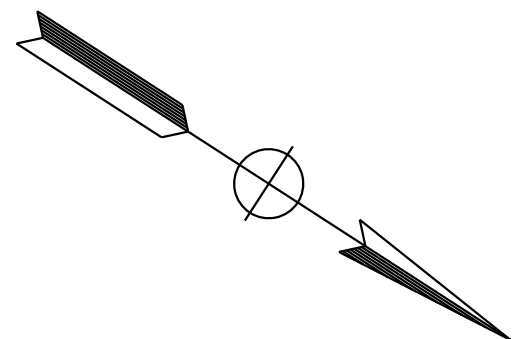

NOTE:  
FOR ACCURATE RIGHT OF WAY DATA, CONTACT  
RIGHT OF WAY ENGINEERING AT THE DISTRICT OFFICE.

STATE OF CALIFORNIA - DEPARTMENT OF TRANSPORTATION	CONSULTANT	FUNCTIONAL SUPERVISOR	CALCULATED- DESIGNED BY	CHECKED BY	JAMEY VALDIVIA	REVISOR	DATE
Er Caltrans®	TIMOTHY J. LEE	JV	ERIN MCPHERSON	9-29-21			

DUBLIN

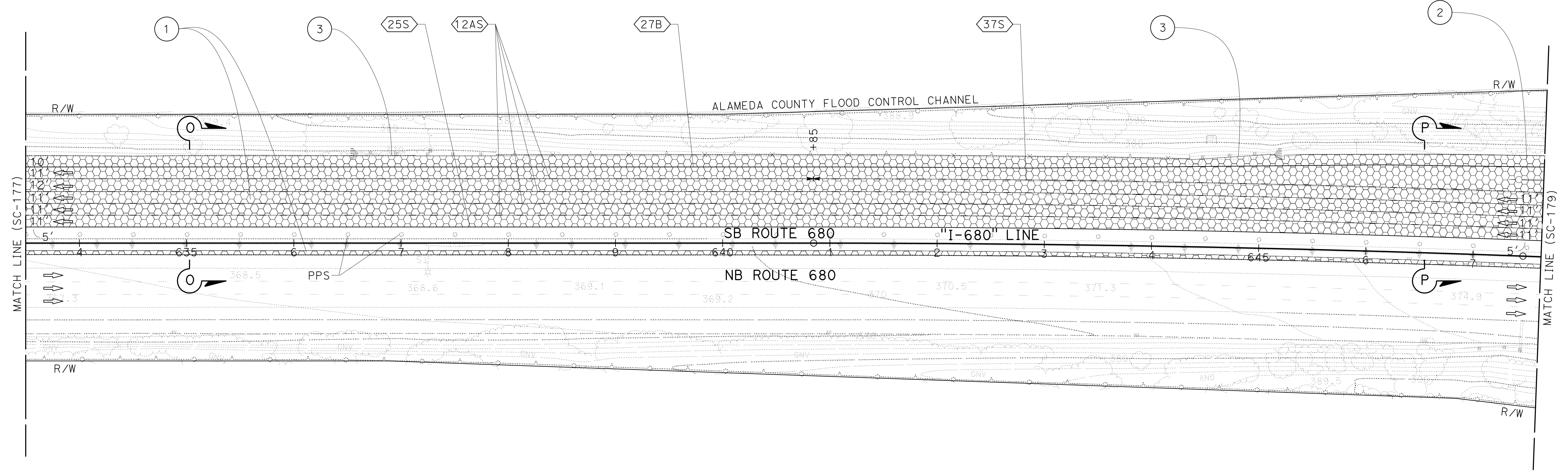

**STAGE CONSTRUCTION  
AND TRAFFIC HANDLING PLAN  
STAGE 3**

SCALE: 1" = 50'

**SC-178**

FOR NOTES, ABBREVIATIONS AND  
LEGEND, SEE SHEET SC-1 AND SC-144

APPROVED FOR STAGE CONSTRUCTION AND TRAFFIC HANDLING WORK ONLY

LAST REVISION: 09-29-21 DATE PLOTTED => 8-MAR-2022 TIME PLOTTED => 10:13

Dist	COUNTY	ROUTE	POST MILES TOTAL PROJECT	SHEET No.	TOTAL SHEETS
04	Ala, CC	680	R11.0/R21.9, R0.0/R0.9	692	1710
			9-29-21		
REGISTERED CIVIL ENGINEER			DATE		
October 8, 2021			PLANS APPROVAL DATE		
<small>THE STATE OF CALIFORNIA OR ITS OFFICERS OR AGENTS SHALL NOT BE RESPONSIBLE FOR THE ACCURACY OR COMPLETENESS OF SCANNED COPIES OF THIS PLAN SHEET.</small>					
WMH CORPORATION 55 South Market St Suite 1200 San Jose, CA 95113			ALAMEDA CTC 1111 Broadway Suite 800 Oakland, CA 94607		



**NOTES:**  
 1. FOR ACCURATE RIGHT OF WAY DATA, CONTACT RIGHT OF WAY ENGINEERING AT THE DISTRICT OFFICE.  
 2. PLACE FINAL PAVEMENT DELINEATION FOR RAMPS, AFTER WIDENING AND OVERLAY COMPLETION. FOR DETAILS SEE PD SHEETS

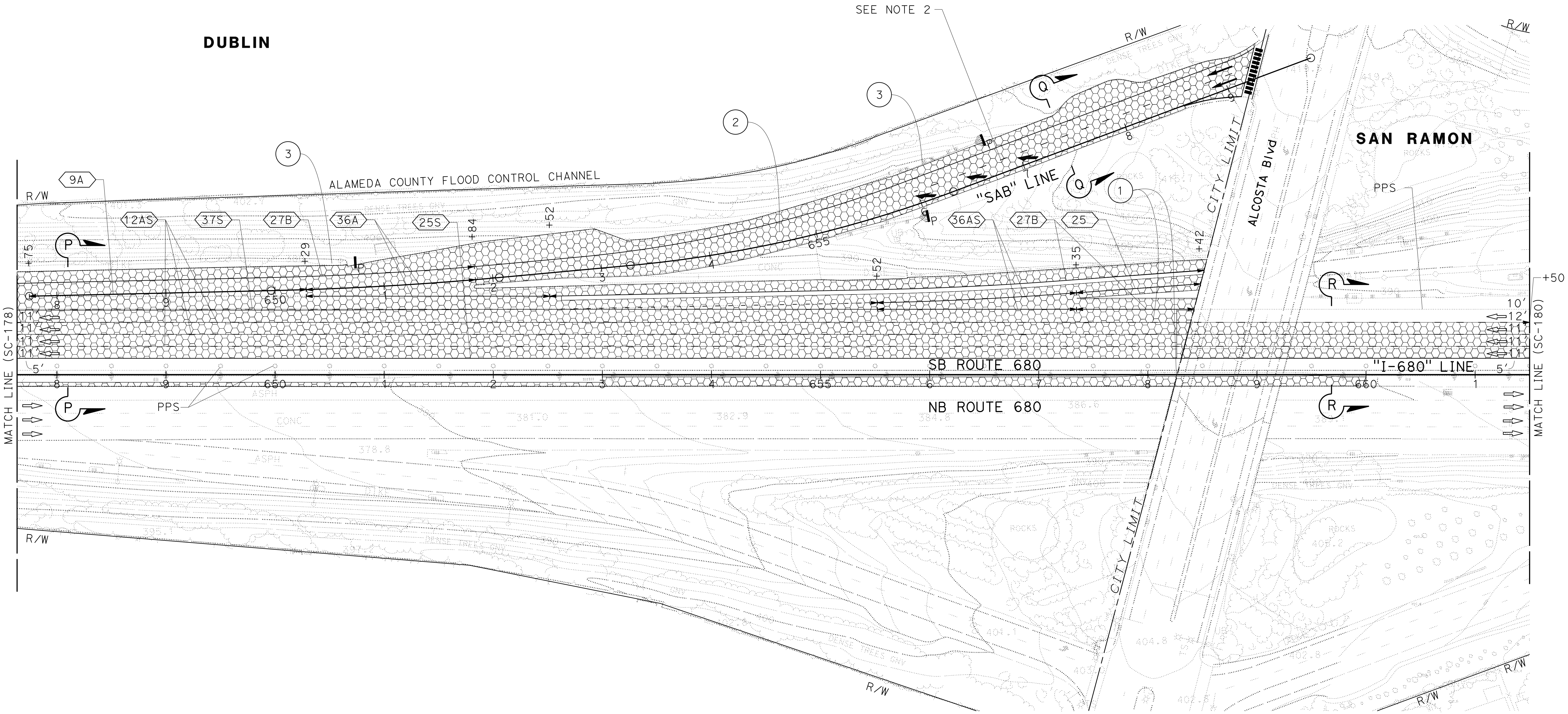
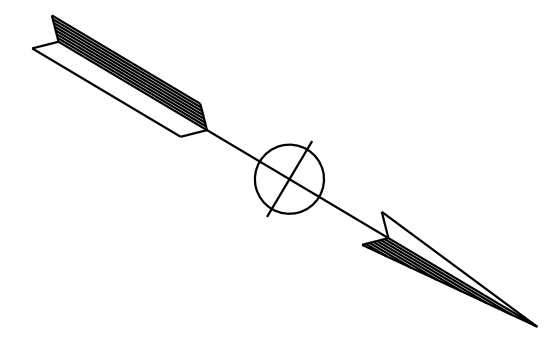

**STAGE CONSTRUCTION  
AND TRAFFIC HANDLING PLAN  
STAGE 3**

SCALE: 1" = 50'

**SC-179**

FOR NOTES, ABBREVIATIONS AND LEGEND, SEE SHEET SC-1 AND SC-144

APPROVED FOR STAGE CONSTRUCTION AND TRAFFIC HANDLING WORK ONLY

STATE OF CALIFORNIA - DEPARTMENT OF TRANSPORTATION	CONSULTANT FUNCTIONAL SUPERVISOR	CALCULATED-DESIGNED BY	REVISOR	DATE
	TIMOTHY J. LEE	JAMEY VALDIVIA	JV	9-29-21
		ERIN McPHERSON		

O:\0030\UDRAFT\ING\FINAL\_P58E\0420000235ma179.dgn

LAST REVISION: DATE PLOTTED => 8-MAR-2022  
09-29-21 TIME PLOTTED => 10:13

Dist	COUNTY	ROUTE	POST MILES TOTAL PROJECT	SHEET No.	TOTAL SHEETS
04	Ala, CC	680	R11.0/R21.9, RO.0/RO.9	693	1710
			9-29-21		
REGISTERED CIVIL ENGINEER			DATE		
October 8, 2021			PLANS APPROVAL DATE		
<small>THE STATE OF CALIFORNIA OR ITS OFFICERS OR AGENTS SHALL NOT BE RESPONSIBLE FOR THE ACCURACY OR COMPLETENESS OF SCANNED COPIES OF THIS PLAN SHEET.</small>					
WMH CORPORATION 55 South Market St Suite 1200 San Jose, CA 95113			ALAMEDA CTC 1111 Broadway Suite 800 Oakland, CA 94607		

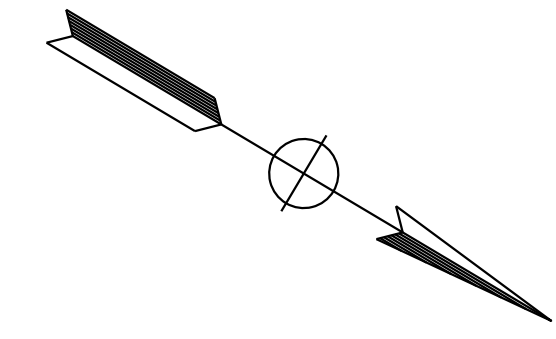

NOTE:  
FOR ACCURATE RIGHT OF WAY DATA, CONTACT  
RIGHT OF WAY ENGINEERING AT THE DISTRICT OFFICE.

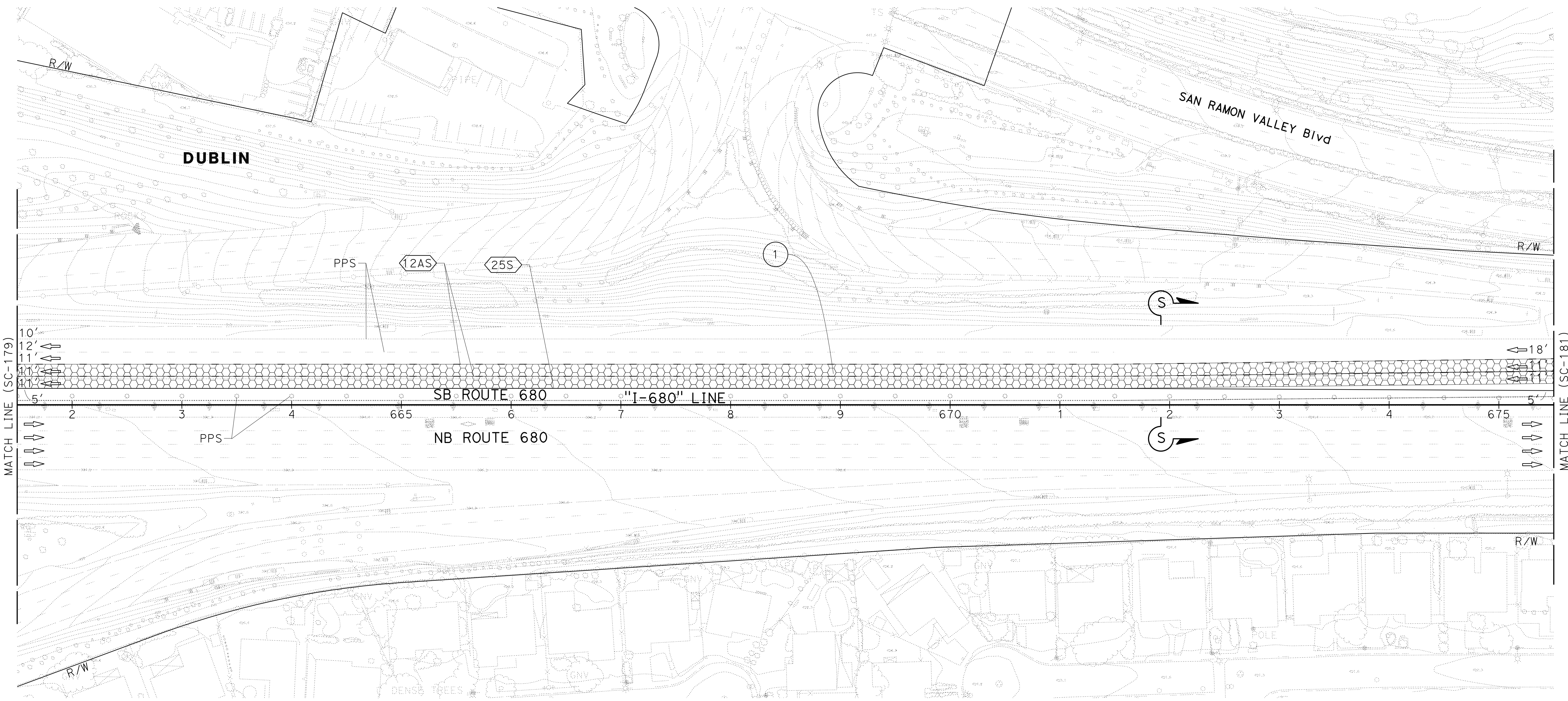

**STAGE CONSTRUCTION  
AND TRAFFIC HANDLING PLAN  
STAGE 3**

SCALE: 1" = 50'

**SC-180**

FOR NOTES, ABBREVIATIONS AND  
LEGEND, SEE SHEET SC-1 AND SC-144

APPROVED FOR STAGE CONSTRUCTION AND TRAFFIC HANDLING WORK ONLY

STATE OF CALIFORNIA - DEPARTMENT OF TRANSPORTATION	CALCULATED/DESIGNED BY	REVISOR	DATE
Erwin McPherson	JAMIEY VALDIVIA	JV	9-29-21
Erwin McPherson	ERIN MCPHERSON		
Timothy J. Lee			

Dist	COUNTY	ROUTE	POST MILES TOTAL PROJECT	SHEET No.	TOTAL SHEETS
04	Ala, CC	680	R11.0/R21.9, R0.0/R0.9	694	1710
			9-29-21		
REGISTERED CIVIL ENGINEER			DATE		
October 8, 2021			PLANS APPROVAL DATE		
WMH CORPORATION 55 South Market St Suite 1200 San Jose, CA 95113			ALAMEDA CTC 1111 Broadway Suite 800 Oakland, CA 94607		

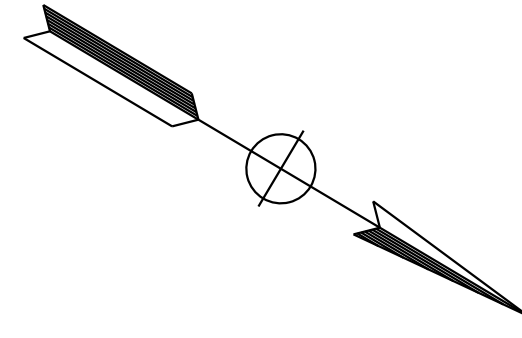

NOTE:  
FOR ACCURATE RIGHT OF WAY DATA, CONTACT  
RIGHT OF WAY ENGINEERING AT THE DISTRICT OFFICE.

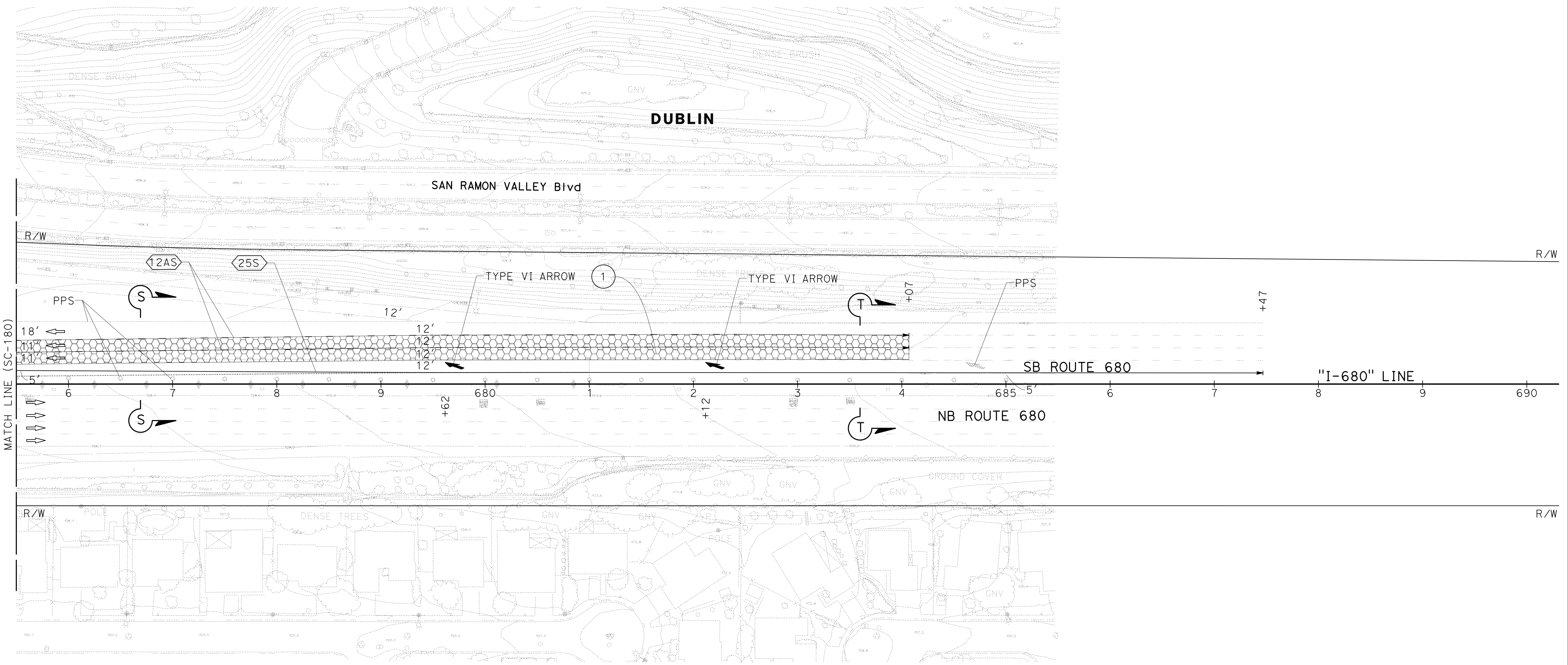

**STAGE CONSTRUCTION  
AND TRAFFIC HANDLING PLAN  
STAGE 3**

SCALE: 1" = 50'

**SC-181**

FOR NOTES, ABBREVIATIONS AND  
LEGEND, SEE SHEET SC-1 AND SC-144

APPROVED FOR STAGE CONSTRUCTION AND TRAFFIC HANDLING WORK ONLY

STATE OF CALIFORNIA - DEPARTMENT OF TRANSPORTATION	CONSULTANT - FUNCTIONAL SUPERVISOR	DESIGNED BY	REVISOR	DATE
	TIMOTHY J. LEE	ERIN MCPHERSON	JV	9-29-21
		JAMEY VALDIVIA		

LAST REVISION: 09-29-21 DATE PLOTTED => 8-MAR-2022 TIME PLOTTED => 10:14

Dist	COUNTY	ROUTE	POST MILES TOTAL PROJECT	SHEET No.	TOTAL SHEETS
04	Ala, CC	680	R11.0/R21.9, RO.0/RO.9	695	1710
			9-29-21		
REGISTERED CIVIL ENGINEER			DATE		
			October 8, 2021		
			PLANS APPROVAL DATE		
<small>THE STATE OF CALIFORNIA OR ITS OFFICERS OR AGENTS SHALL NOT BE RESPONSIBLE FOR THE ACCURACY OR COMPLETENESS OF SCANNED COPIES OF THIS PLAN SHEET.</small>					
WMH CORPORATION 55 South Market St Suite 1200 San Jose, CA 95113			ALAMEDA CTC 1111 Broadway Suite 800 Oakland, CA 94607		

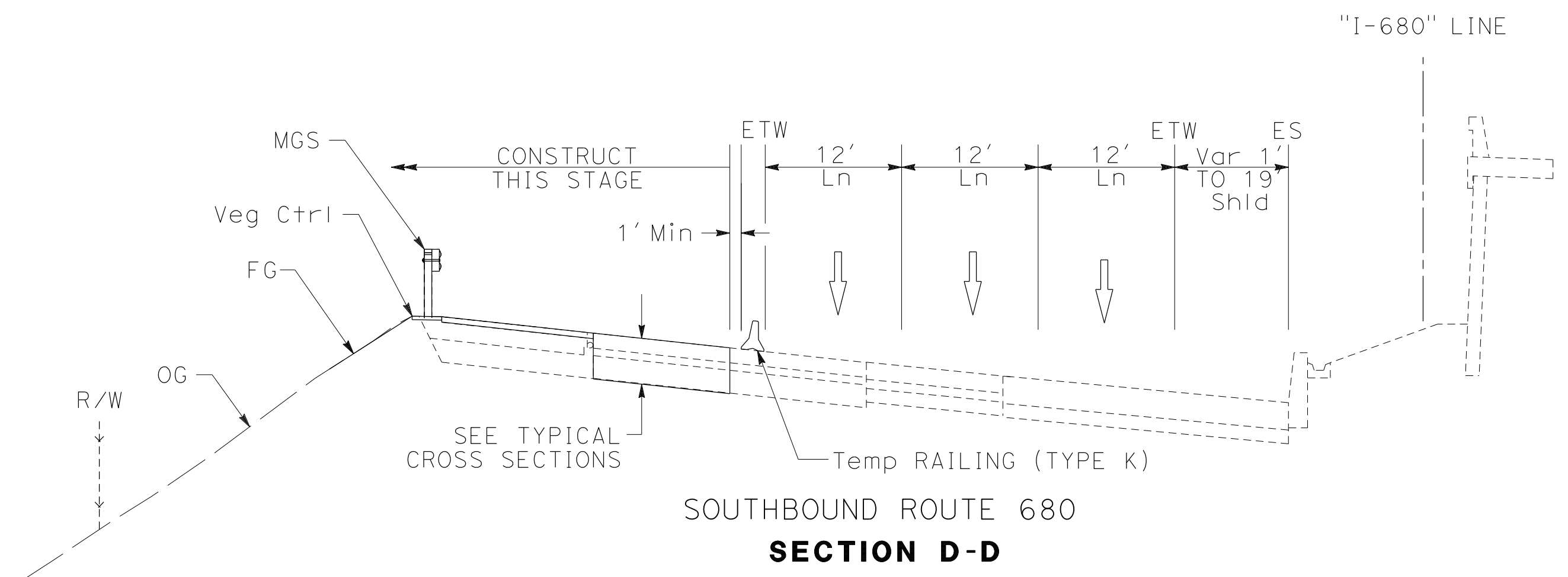
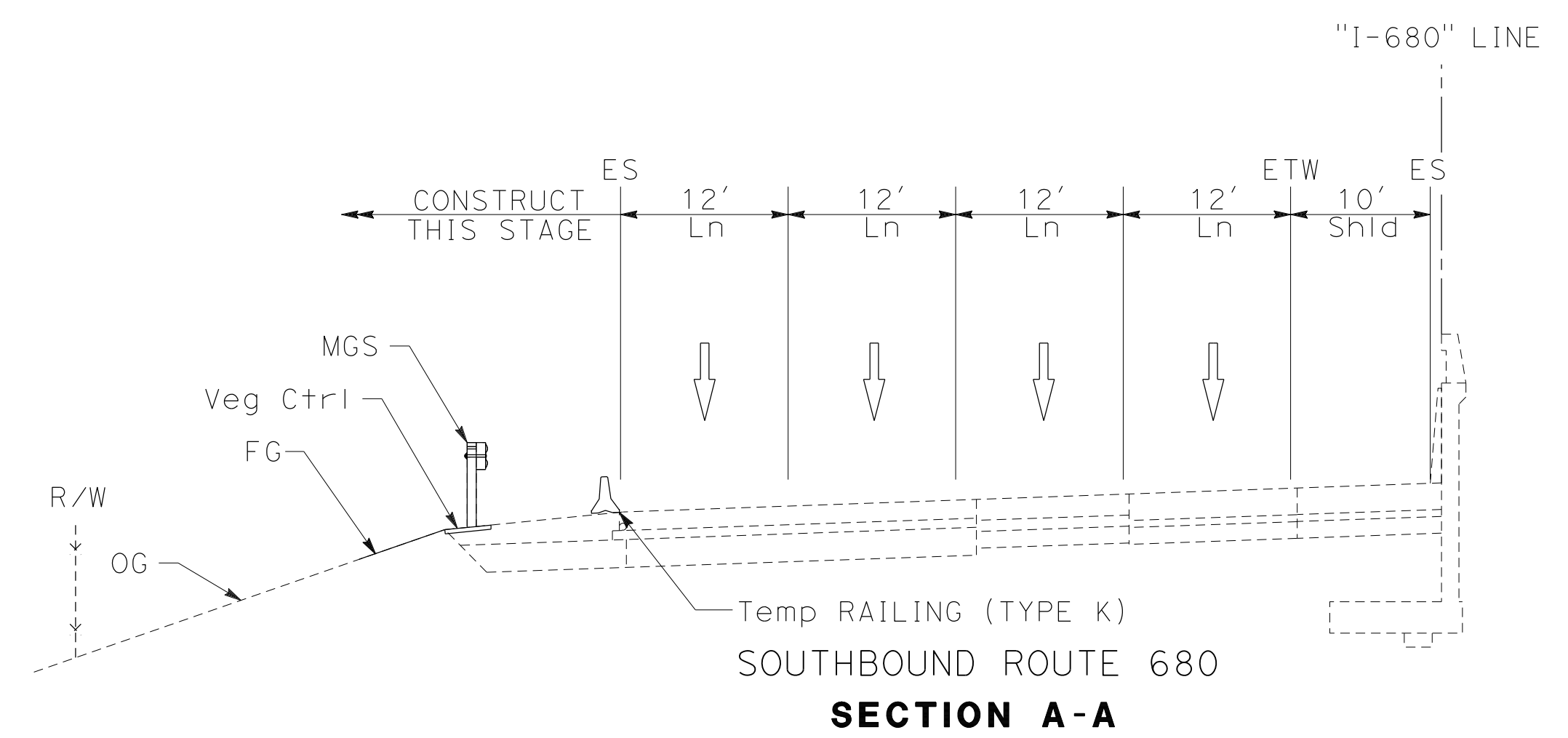
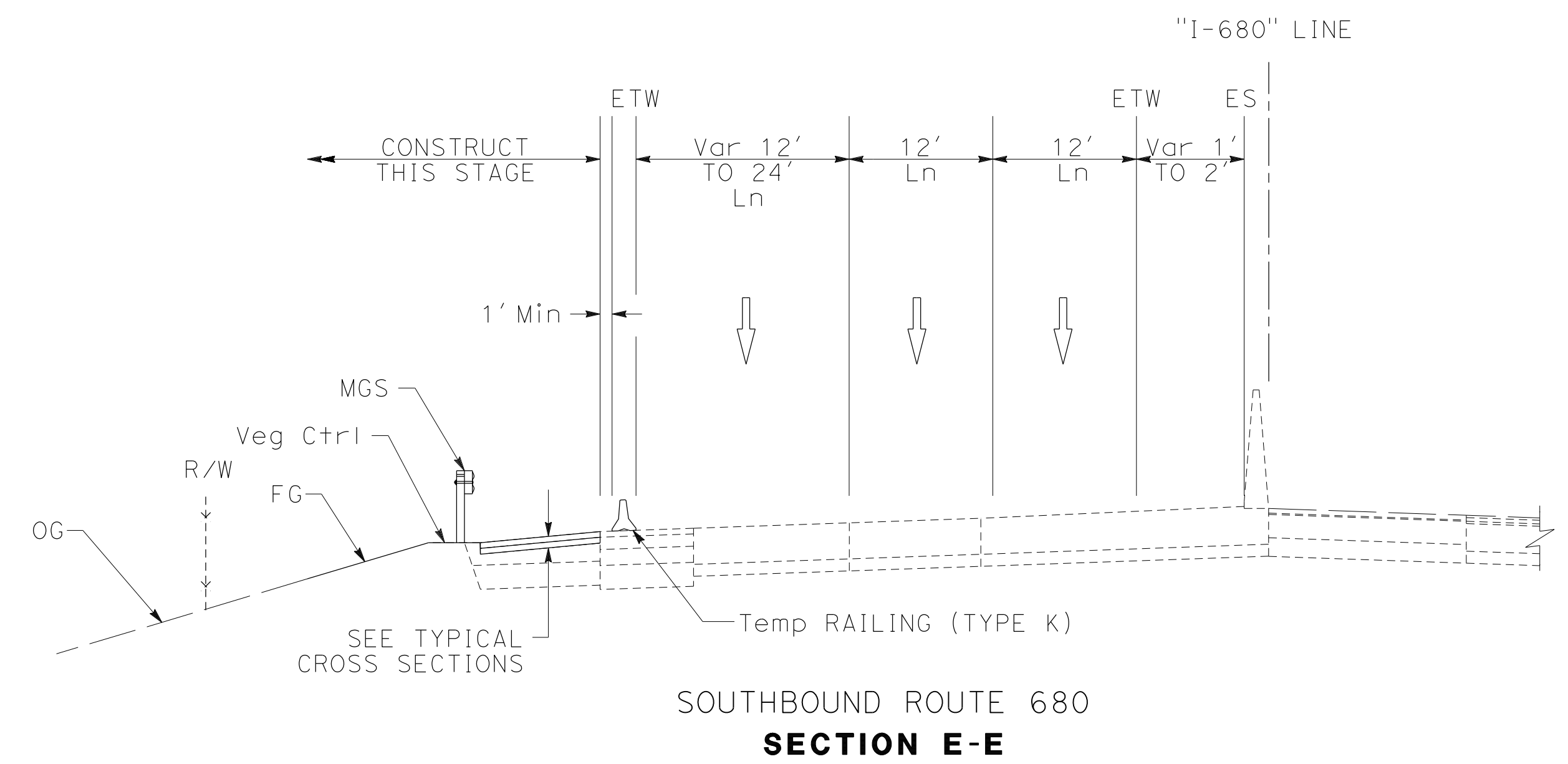
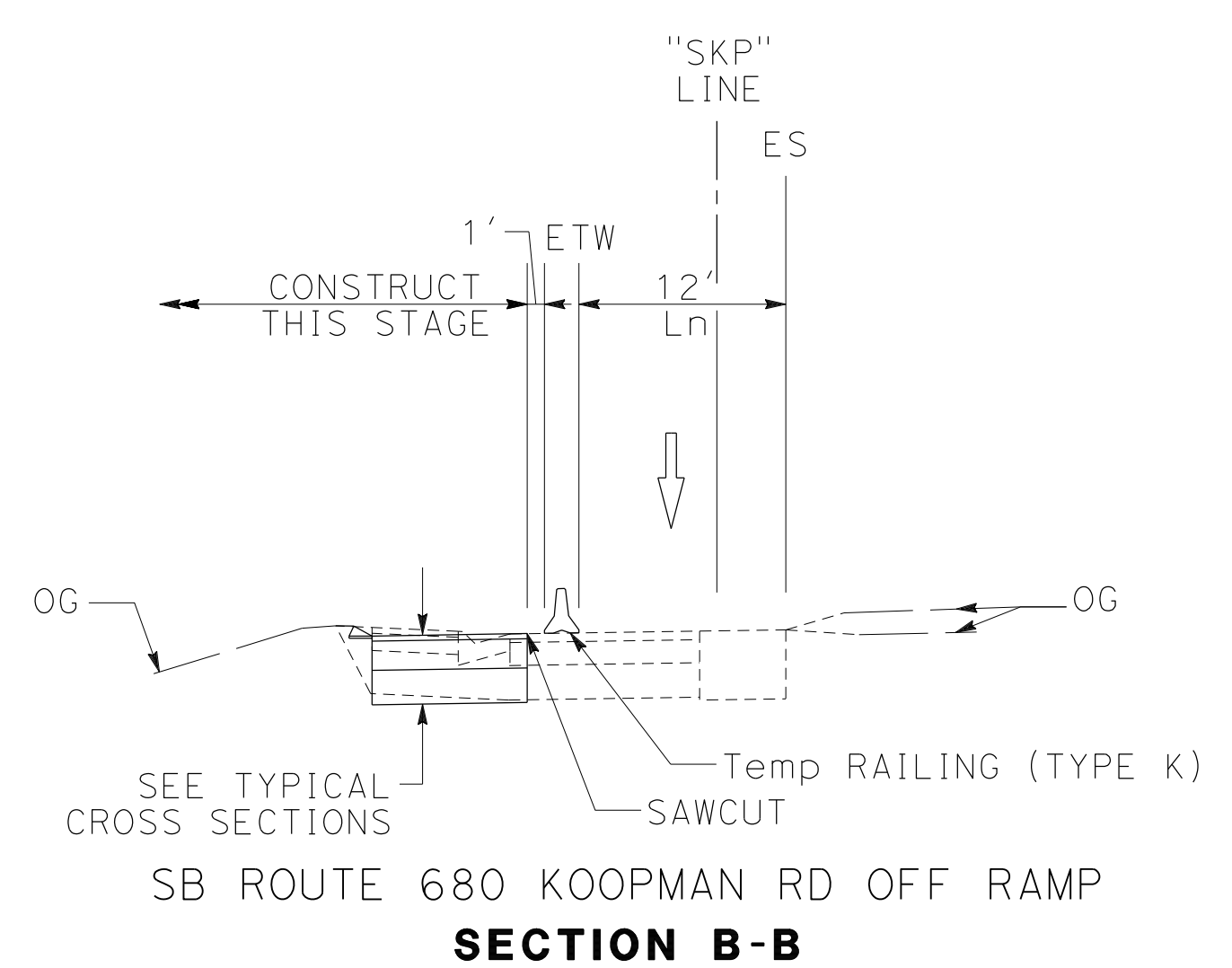
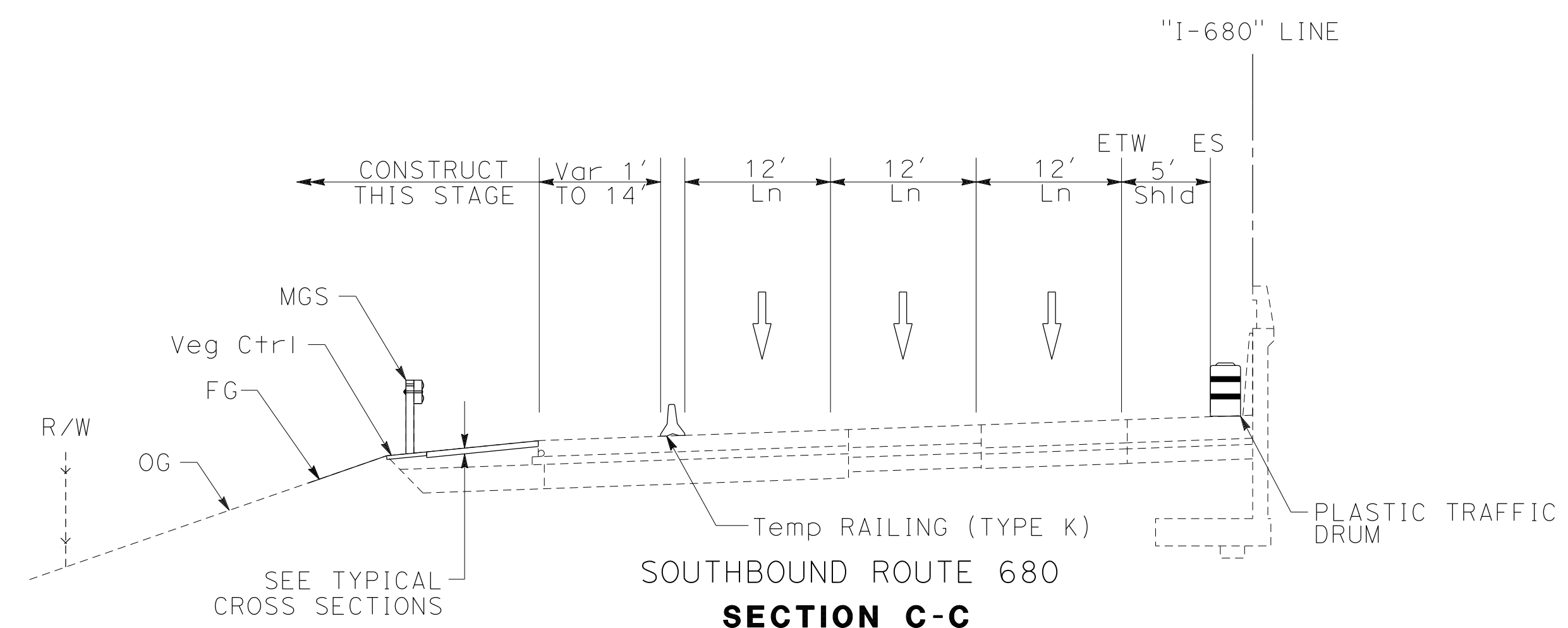
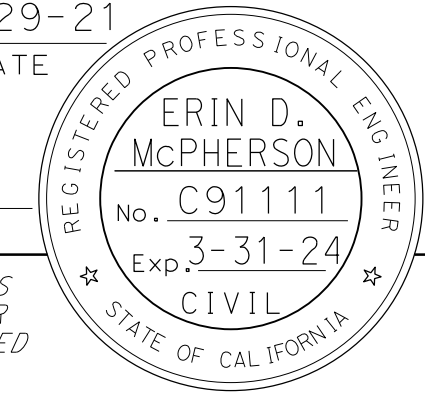

**STAGE CONSTRUCTION AND TRAFFIC HANDLING PLAN**  
**STAGE 4**

NO SCALE

**SC-182**

FOR NOTES, ABBREVIATIONS AND LEGEND, SEE SHEET SC-1 AND SC-186

X:\680\_SB\_GAP\_EXPRESS\000\_CAD\Submittal\CADD\_submittal\0420000235ma182.dgn  
 STATE OF CALIFORNIA - DEPARTMENT OF TRANSPORTATION  
 CONSULTANT FUNCTIONAL SUPERVISOR  
 CONSULTANT  
 JAMEY VALDIVIA  
 ERIN MCPHERSON  
 REVISIONS  
 REVISION NO. DATE REVISION BY DATE REVISION BY  
 1 9-29-21 J.V.  
 2  
 3  
 4  
 5  
 6  
 7  
 8  
 9  
 10  
 11  
 12  
 13  
 14  
 15  
 16  
 17  
 18  
 19  
 20  
 21  
 22  
 23  
 24  
 25  
 26  
 27  
 28  
 29  
 30  
 31  
 32  
 33  
 34  
 35  
 36  
 37  
 38  
 39  
 40  
 41  
 42  
 43  
 44  
 45  
 46  
 47  
 48  
 49  
 50  
 51  
 52  
 53  
 54  
 55  
 56  
 57  
 58  
 59  
 60  
 61  
 62  
 63  
 64  
 65  
 66  
 67  
 68  
 69  
 70  
 71  
 72  
 73  
 74  
 75  
 76  
 77  
 78  
 79  
 80  
 81  
 82  
 83  
 84  
 85  
 86  
 87  
 88  
 89  
 90  
 91  
 92  
 93  
 94  
 95  
 96  
 97  
 98  
 99  
 100  
 101  
 102  
 103  
 104  
 105  
 106  
 107  
 108  
 109  
 110  
 111  
 112  
 113  
 114  
 115  
 116  
 117  
 118  
 119  
 120  
 121  
 122  
 123  
 124  
 125  
 126  
 127  
 128  
 129  
 130  
 131  
 132  
 133  
 134  
 135  
 136  
 137  
 138  
 139  
 140  
 141  
 142  
 143  
 144  
 145  
 146  
 147  
 148  
 149  
 150  
 151  
 152  
 153  
 154  
 155  
 156  
 157  
 158  
 159  
 160  
 161  
 162  
 163  
 164  
 165  
 166  
 167  
 168  
 169  
 170  
 171  
 172  
 173  
 174  
 175  
 176  
 177  
 178  
 179  
 180  
 181  
 182  
 183  
 184  
 185  
 186  
 187  
 188  
 189  
 190  
 191  
 192  
 193  
 194  
 195  
 196  
 197  
 198  
 199  
 200  
 201  
 202  
 203  
 204  
 205  
 206  
 207  
 208  
 209  
 210  
 211  
 212  
 213  
 214  
 215  
 216  
 217  
 218  
 219  
 220  
 221  
 222  
 223  
 224  
 225  
 226  
 227  
 228  
 229  
 230  
 231  
 232  
 233  
 234  
 235  
 236  
 237  
 238  
 239  
 240  
 241  
 242  
 243  
 244  
 245  
 246  
 247  
 248  
 249  
 250  
 251  
 252  
 253  
 254  
 255  
 256  
 257  
 258  
 259  
 260  
 261  
 262  
 263  
 264  
 265  
 266  
 267  
 268  
 269  
 270  
 271  
 272  
 273  
 274  
 275  
 276  
 277  
 278  
 279  
 280  
 281  
 282  
 283  
 284  
 285  
 286  
 287  
 288  
 289  
 290  
 291  
 292  
 293  
 294  
 295  
 296  
 297  
 298  
 299  
 300  
 301  
 302  
 303  
 304  
 305  
 306  
 307  
 308  
 309  
 310  
 311  
 312  
 313  
 314  
 315  
 316  
 317  
 318  
 319  
 320  
 321  
 322  
 323  
 324  
 325  
 326  
 327  
 328  
 329  
 330  
 331  
 332  
 333  
 334  
 335  
 336  
 337  
 338  
 339  
 340  
 341  
 342  
 343  
 344  
 345  
 346  
 347  
 348  
 349  
 350  
 351  
 352  
 353  
 354  
 355  
 356  
 357  
 358  
 359  
 360  
 361  
 362  
 363  
 364  
 365  
 366  
 367  
 368  
 369  
 370  
 371  
 372  
 373  
 374  
 375  
 376  
 377  
 378  
 379  
 380  
 381  
 382  
 383  
 384  
 385  
 386  
 387  
 388  
 389  
 390  
 391  
 392  
 393  
 394  
 395  
 396  
 397  
 398  
 399  
 400  
 401  
 402  
 403  
 404  
 405  
 406  
 407  
 408  
 409  
 410  
 411  
 412  
 413  
 414  
 415  
 416  
 417  
 418  
 419  
 420  
 421  
 422  
 423  
 424  
 425  
 426  
 427  
 428  
 429  
 430  
 431  
 432  
 433  
 434  
 435  
 436  
 437  
 438  
 439  
 440  
 441  
 442  
 443  
 444  
 445  
 446  
 447  
 448  
 449  
 450  
 451  
 452  
 453  
 454  
 455  
 456  
 457  
 458  
 459  
 460  
 461  
 462  
 463  
 464  
 465  
 466  
 467  
 468  
 469  
 470  
 471  
 472  
 473  
 474  
 475  
 476  
 477  
 478  
 479  
 480  
 481  
 482  
 483  
 484  
 485  
 486  
 487  
 488  
 489  
 490  
 491  
 492  
 493  
 494  
 495  
 496  
 497  
 498  
 499  
 500  
 501  
 502  
 503  
 504  
 505  
 506  
 507  
 508  
 509  
 510  
 511  
 512  
 513  
 514  
 515  
 516  
 517  
 518  
 519  
 520  
 521  
 522  
 523  
 524  
 525  
 526  
 527  
 528  
 529  
 530  
 531  
 532  
 533  
 534  
 535  
 536  
 537  
 538  
 539  
 540  
 541  
 542  
 543  
 544  
 545  
 546  
 547  
 548  
 549  
 550  
 551  
 552  
 553  
 554  
 555  
 556  
 557  
 558  
 559  
 560  
 561  
 562  
 563  
 564  
 565  
 566  
 567  
 568  
 569  
 570  
 571  
 572  
 573  
 574  
 575  
 576  
 577  
 578  
 579  
 580  
 581  
 582  
 583  
 584  
 585  
 586  
 587  
 588  
 589  
 590  
 591  
 592  
 593  
 594  
 595  
 596  
 597  
 598  
 599  
 600  
 601  
 602  
 603  
 604  
 605  
 606  
 607  
 608  
 609  
 610  
 611  
 612  
 613  
 614  
 615  
 616  
 617  
 618  
 619  
 620  
 621  
 622  
 623  
 624  
 625  
 626  
 627  
 628  
 629  
 630  
 631  
 632  
 633  
 634  
 635  
 636  
 637  
 638  
 639  
 640  
 641  
 642  
 643  
 644  
 645  
 646  
 647  
 648  
 649  
 650  
 651  
 652  
 653  
 654  
 655  
 656  
 657  
 658  
 659  
 660  
 661  
 662  
 663  
 664  
 665  
 666  
 667  
 668  
 669  
 670  
 671  
 672  
 673  
 674  
 675  
 676  
 677  
 678  
 679  
 680  
 681  
 682  
 683  
 684  
 685  
 686  
 687  
 688  
 689  
 690  
 691  
 692  
 693  
 694  
 695  
 696  
 697  
 698  
 699  
 700  
 701  
 702  
 703  
 704  
 705  
 706  
 707  
 708  
 709  
 710  
 711  
 712  
 713  
 714  
 715  
 716  
 717  
 718  
 719  
 720  
 721  
 722  
 723  
 724  
 725  
 726  
 727  
 728  
 729  
 730  
 731  
 732  
 733  
 734  
 735  
 736  
 737  
 738  
 739  
 740  
 741  
 742  
 743  
 744  
 745  
 746  
 747  
 748  
 749  
 750  
 751  
 752  
 753  
 754  
 755  
 756  
 757  
 758  
 759  
 760  
 761  
 762  
 763  
 764  
 765  
 766  
 767  
 768  
 769  
 770  
 771  
 772  
 773  
 774  
 775  
 776  
 777  
 778  
 779  
 780  
 781  
 782  
 783  
 784  
 785  
 786  
 787  
 788  
 789  
 790  
 791  
 792  
 793  
 794  
 795  
 796  
 797  
 798  
 799  
 800  
 801  
 802  
 803  
 804  
 805  
 806  
 807  
 808  
 809  
 810  
 811  
 812  
 813  
 814  
 815  
 816  
 817  
 818  
 819  
 820  
 821  
 822  
 823  
 824  
 825  
 826  
 827  
 828  
 829  
 830  
 831  
 832  
 833  
 834  
 835  
 836  
 837  
 838  
 839  
 840  
 841  
 842  
 843  
 844  
 845  
 846  
 847  
 848  
 849  
 850  
 851  
 852  
 853  
 854  
 855  
 856  
 857  
 858  
 859  
 860  
 861  
 862  
 863  
 864  
 865  
 866  
 867  
 868  
 869  
 870  
 871  
 872  
 873  
 874  
 875  
 876  
 877  
 878  
 879  
 880  
 881  
 882  
 883  
 884  
 885  
 886  
 887  
 888  
 889  
 890  
 891  
 892  
 893  
 894  
 895  
 896  
 897  
 898  
 899  
 900  
 901  
 902  
 903  
 904  
 905  
 906  
 907  
 908  
 909  
 910  
 911  
 912  
 913  
 914  
 915  
 916  
 917  
 918  
 919  
 920  
 921  
 922  
 923  
 924  
 925  
 926  
 927  
 928  
 929  
 930  
 931  
 932  
 933  
 934  
 935  
 936  
 937  
 938  
 939  
 940  
 941  
 942  
 943  
 944  
 945  
 946  
 947  
 948  
 949  
 950  
 951  
 952  
 953  
 954  
 955  
 956  
 957  
 958  
 959  
 960  
 961  
 962  
 963  
 964  
 965  
 966  
 967  
 968  
 969  
 970  
 971  
 972  
 973  
 974  
 975  
 976  
 977  
 978  
 979  
 980  
 981  
 982  
 983  
 984  
 985  
 986  
 987  
 988  
 989  
 990  
 991  
 992  
 993  
 994  
 995  
 996  
 997  
 998  
 999  
 1000

Dist	COUNTY	ROUTE	POST MILES TOTAL PROJECT	SHEET No.	TOTAL SHEETS
04	Ala, CC	680	R11.0/R21.9, RO.0/RO.9	696	1710
 REGISTERED CIVIL ENGINEER			9-29-21	DATE	
October 8, 2021			PLANS APPROVAL DATE		
THE STATE OF CALIFORNIA OR ITS OFFICERS OR AGENTS SHALL NOT BE RESPONSIBLE FOR THE ACCURACY OR COMPLETENESS OF SCANNED COPIES OF THIS PLAN SHEET.					
WMH CORPORATION 55 South Market St Suite 1200 San Jose, CA 95113			ALAMEDA CTC 1111 Broadway Suite 800 Oakland, CA 94607		

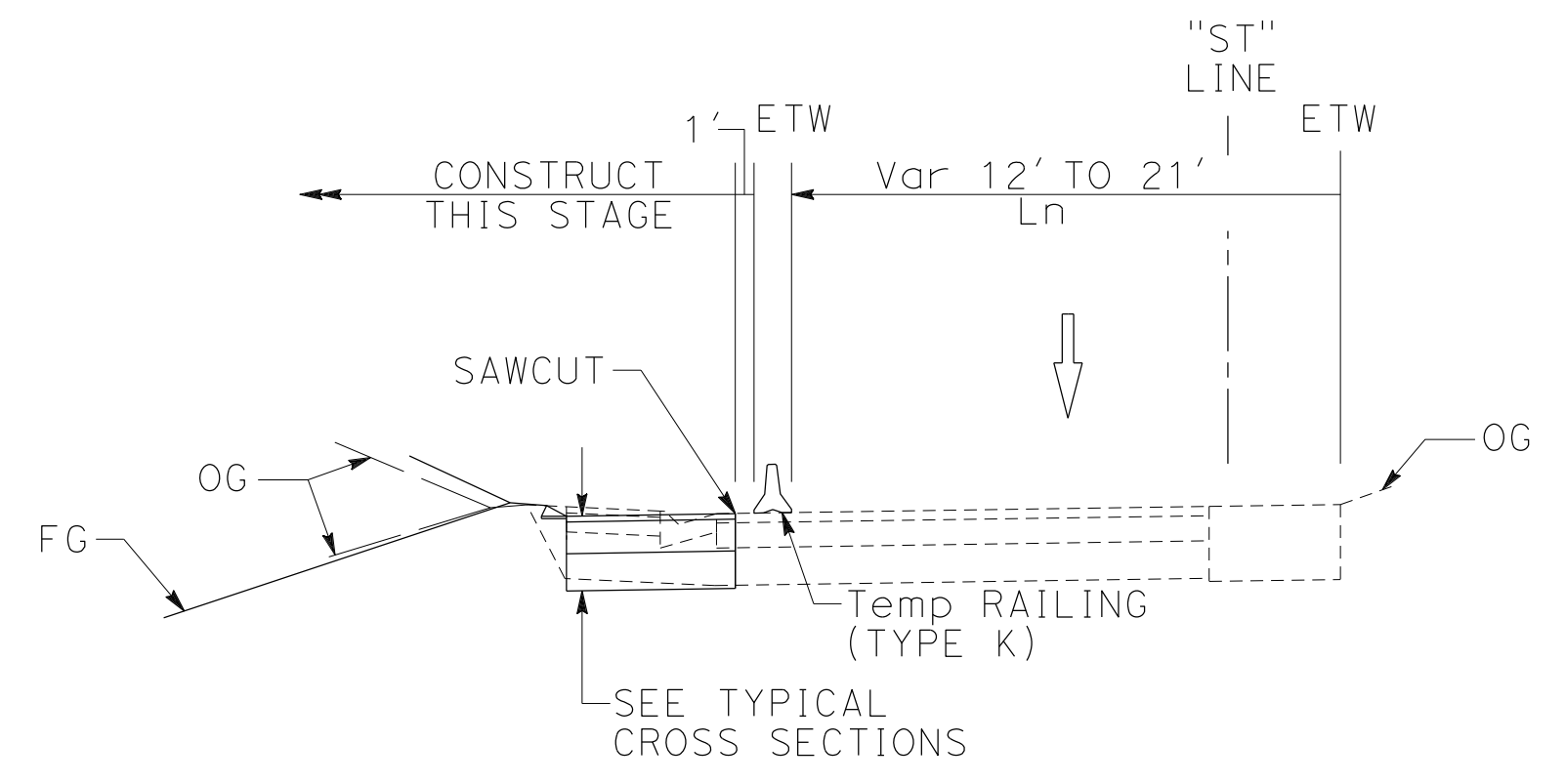

SB ROUTE 680 SUNOL BLVD OFF RAMP  
**SECTION H-H**

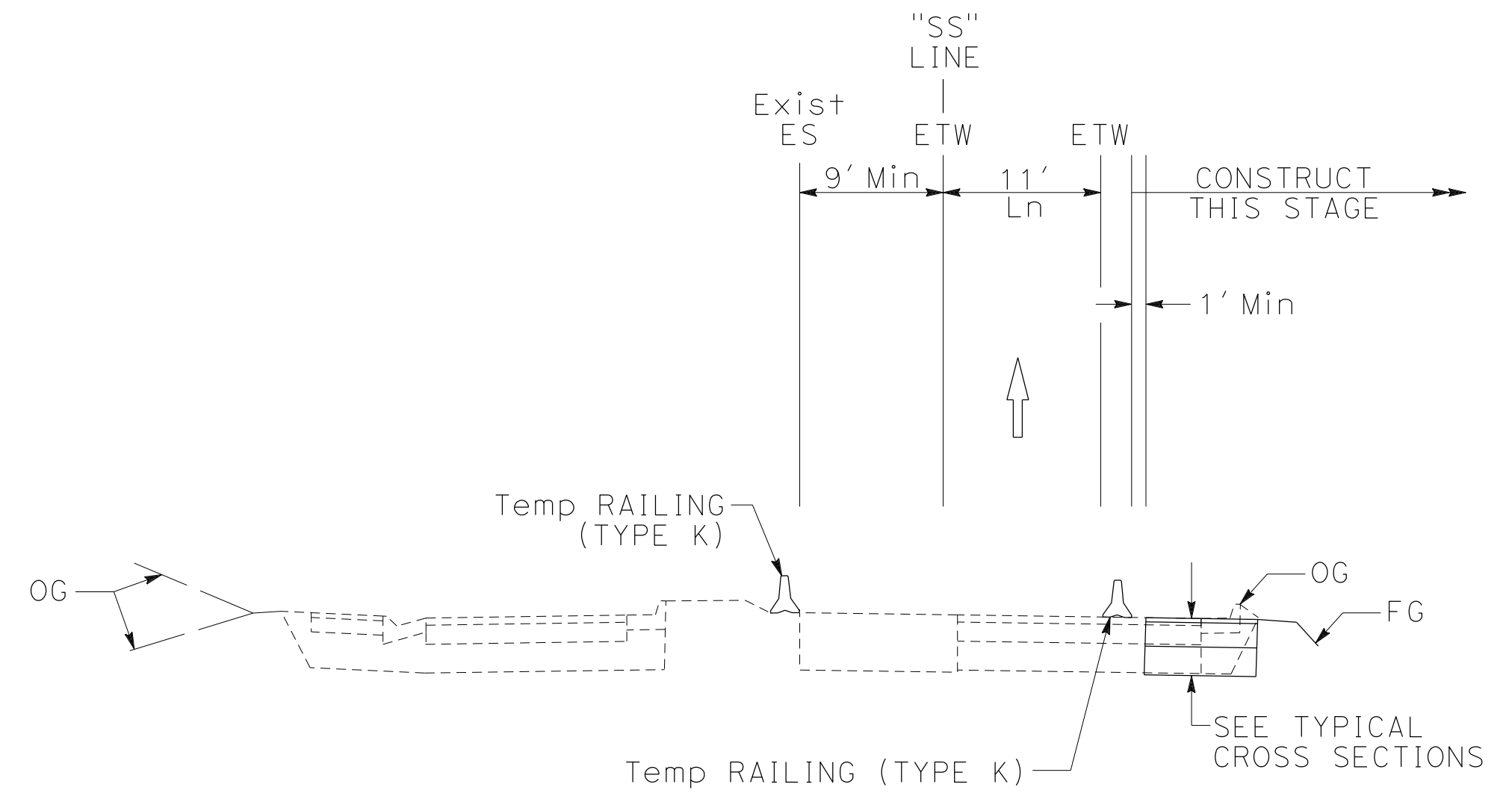

SB ROUTE 680 SUNOL BLVD ON RAMP  
**SECTION G-G**

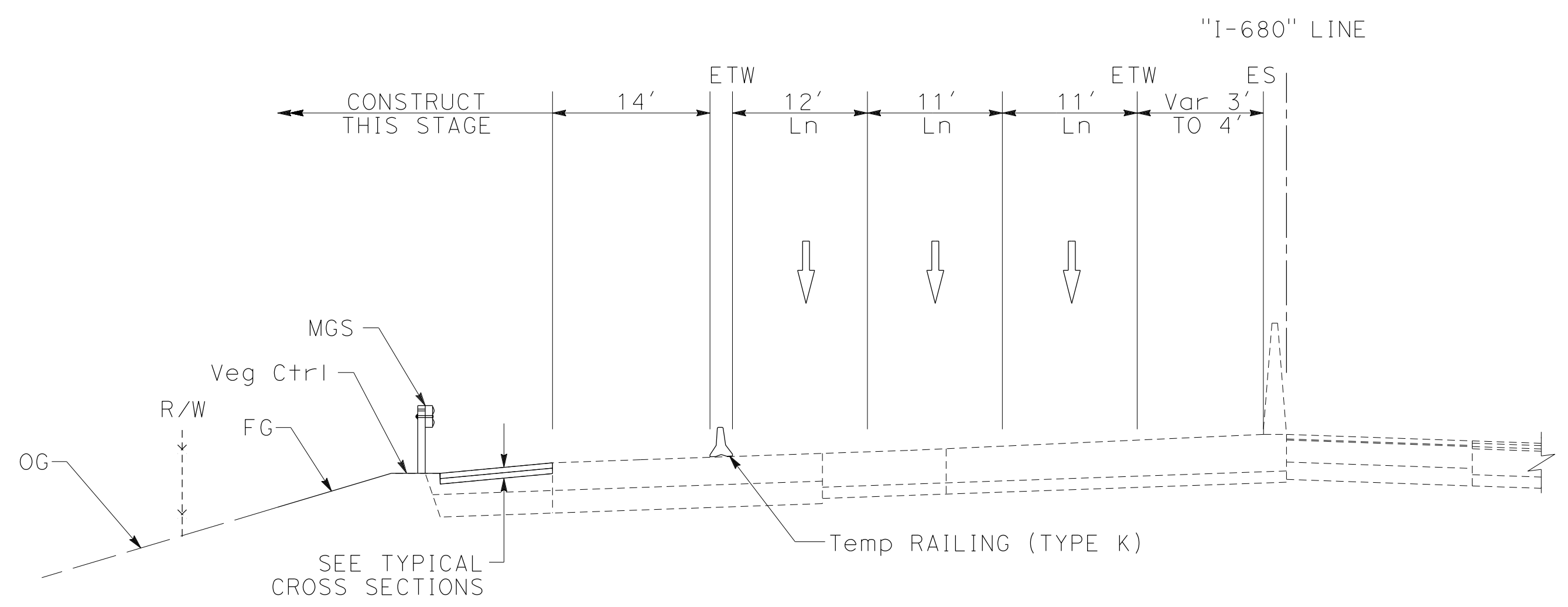

SOUTHBOUND ROUTE 680  
**SECTION F-F**

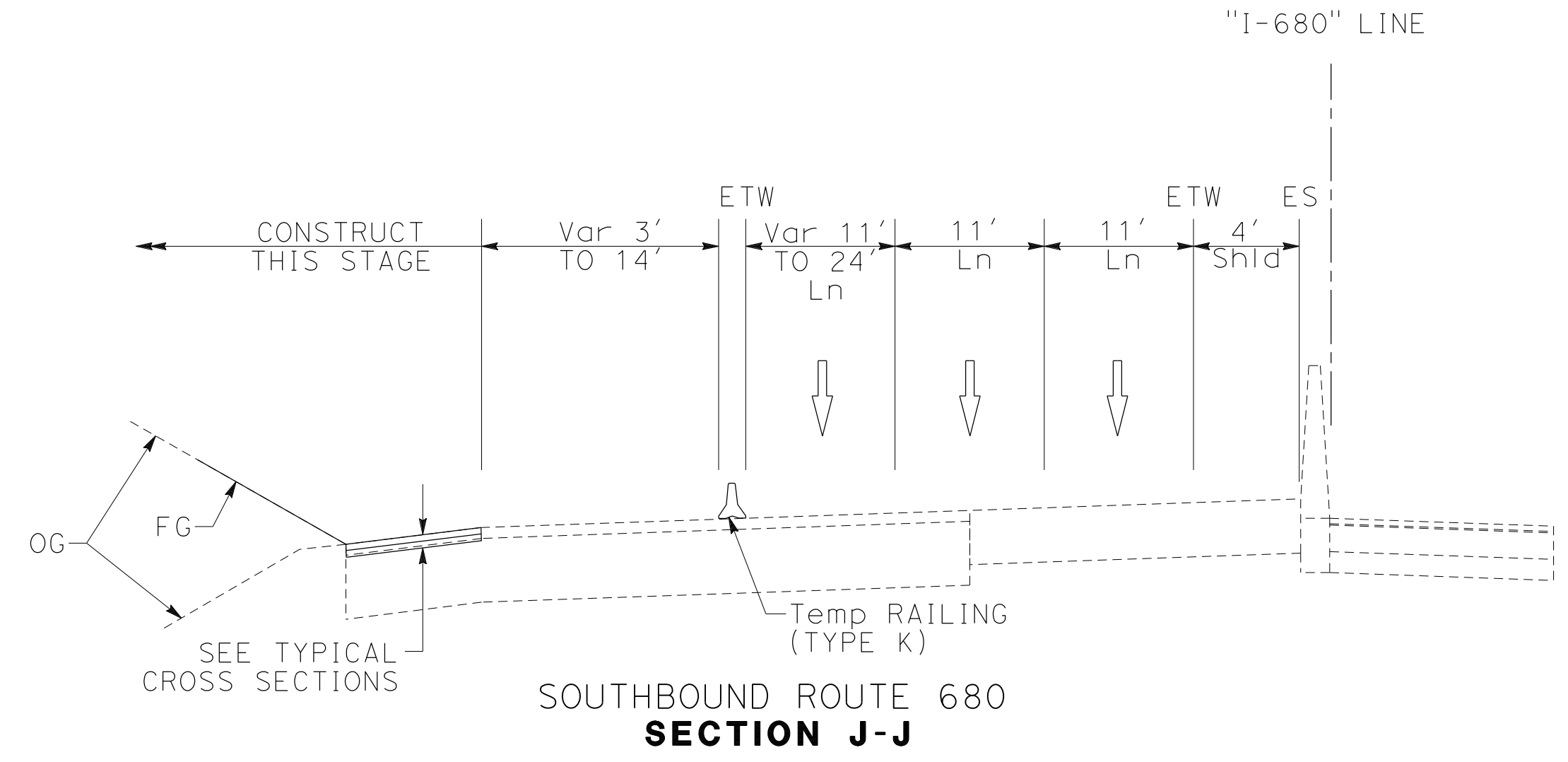

SOUTHBOUND ROUTE 680  
**SECTION J-J**

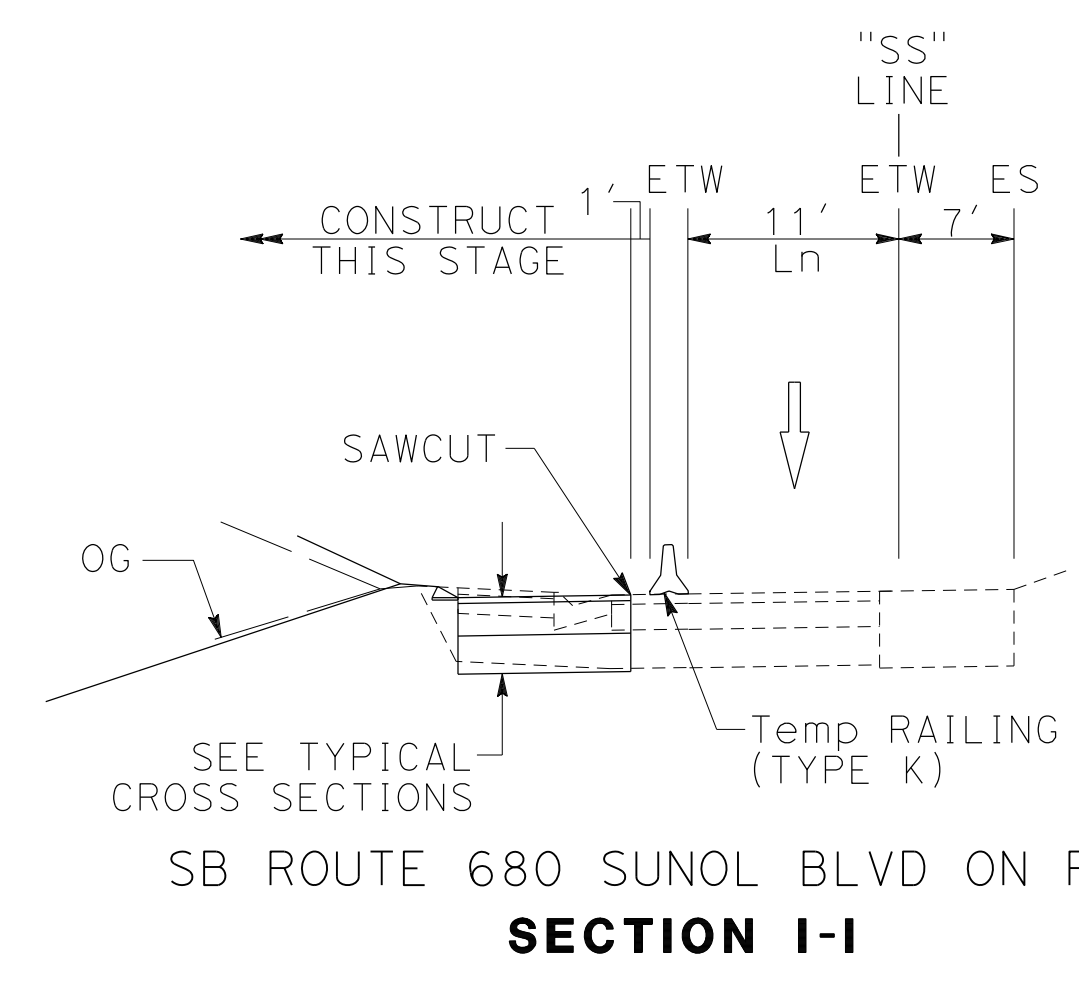

SB ROUTE 680 SUNOL BLVD ON RAMP  
**SECTION I-I**

**STAGE CONSTRUCTION AND TRAFFIC HANDLING PLAN  
STAGE 4**

NO SCALE

**SC-183**

FOR NOTES, ABBREVIATIONS AND LEGEND, SEE SHEET SC-1 AND SC-186

DESIGNED BY	JV	DATE	9-29-21
REVISOR	JV	DATE	9-29-21
CHECKED BY	ERIN MCPHERSON		
DESIGNED BY	JAMIE VALDIVIA		
CHECKED BY	ERIN MCPHERSON		
DESIGNED BY	TIMOTHY J. LEE		
CHECKED BY			

Dist	COUNTY	ROUTE	POST MILES TOTAL PROJECT	SHEET No.	TOTAL SHEETS
04	Ala, CC	680	R11.0/R21.9, RO.0/RO.9	697	1710
			9-29-21		
REGISTERED CIVIL ENGINEER			DATE		
October 8, 2021			PLANS APPROVAL DATE		
WMH CORPORATION 55 South Market St Suite 1200 San Jose, CA 95113			ALAMEDA CTC 1111 Broadway Suite 800 Oakland, CA 94607		

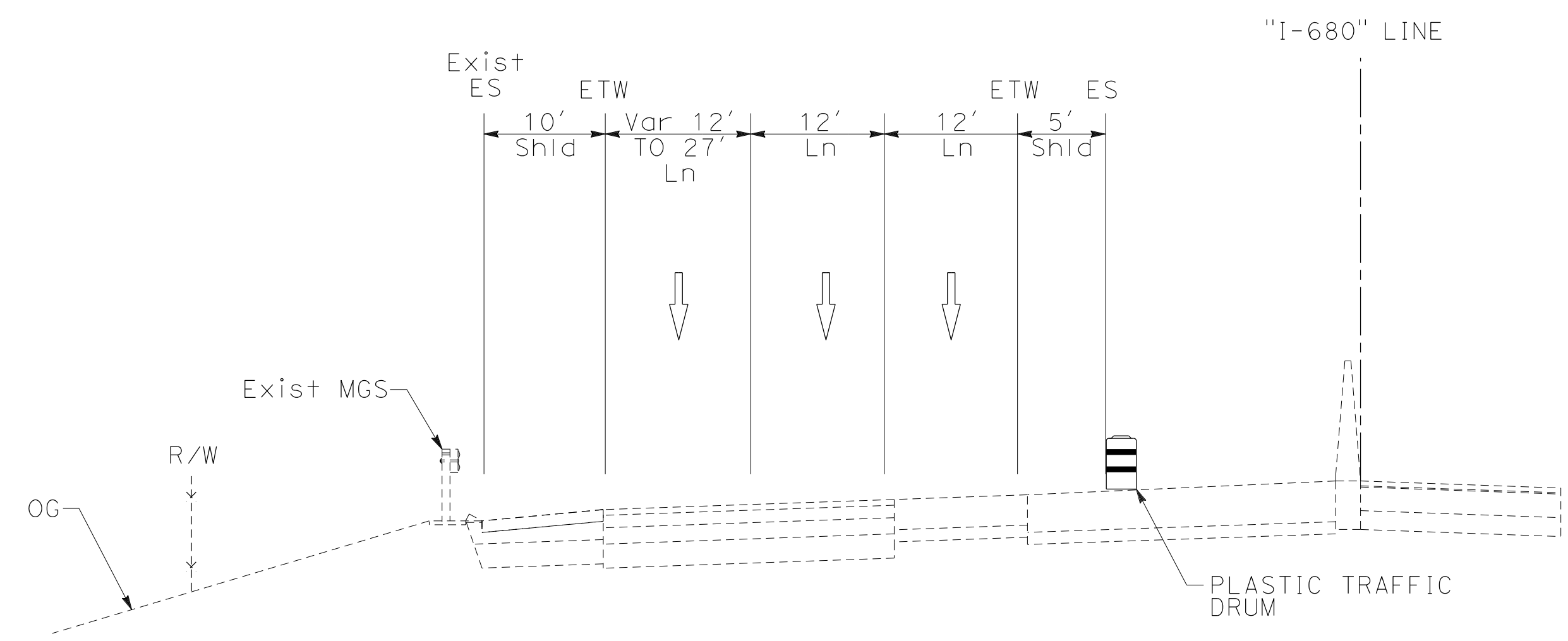

SOUTHBOUND ROUTE 680  
**SECTION M-M**

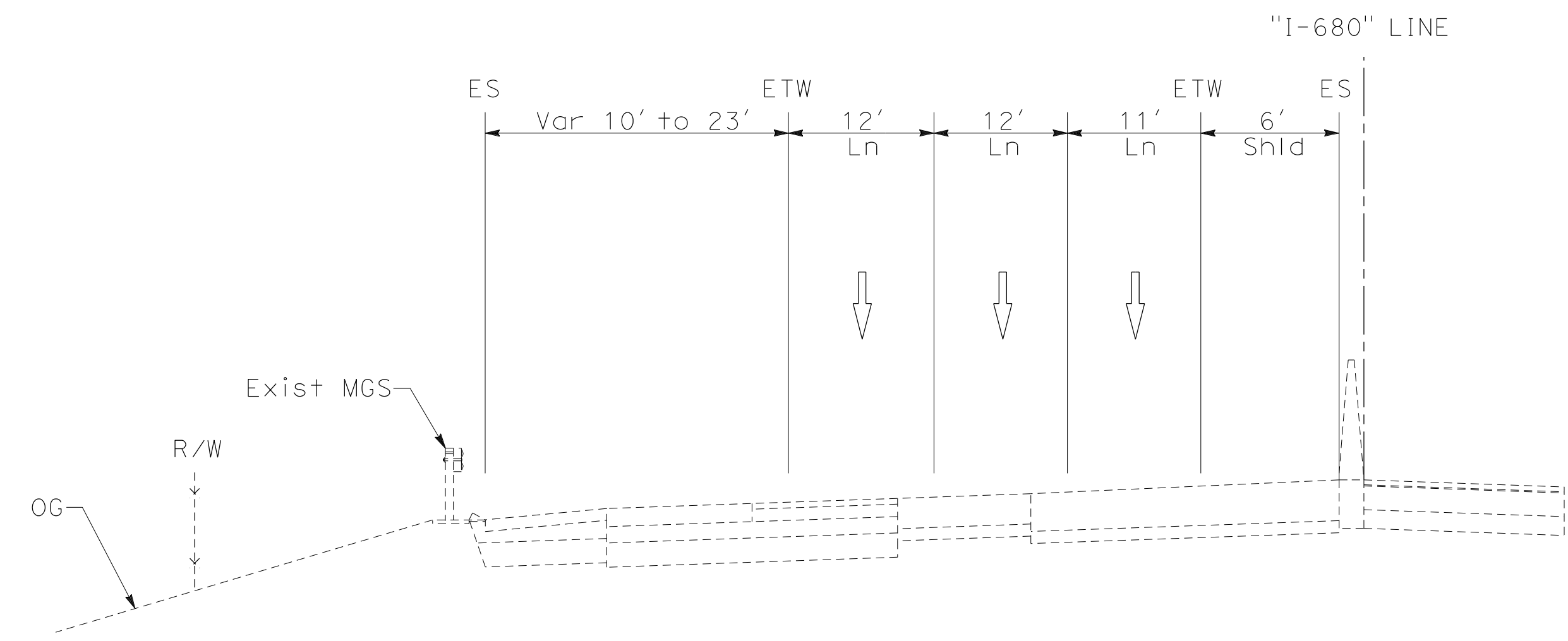

SOUTHBOUND ROUTE 680  
**SECTION L-L**

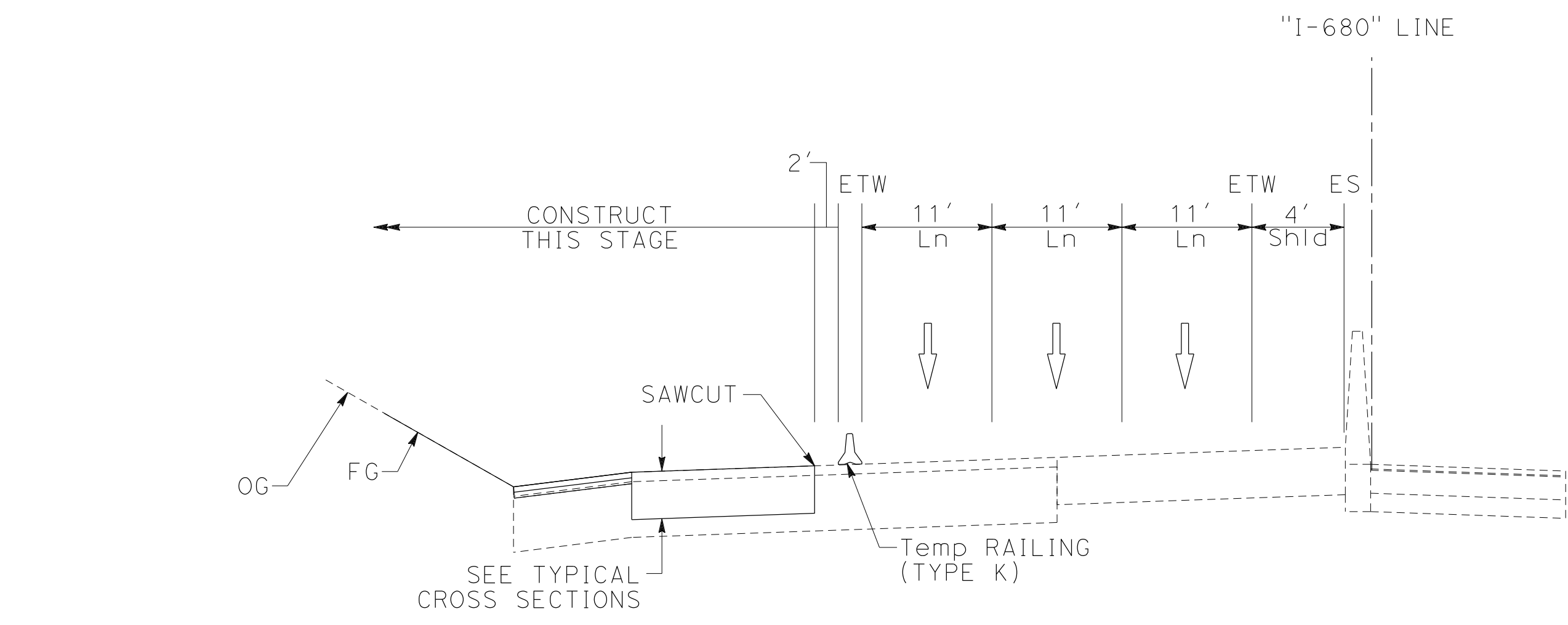

SOUTHBOUND ROUTE 680  
**SECTION K-K**

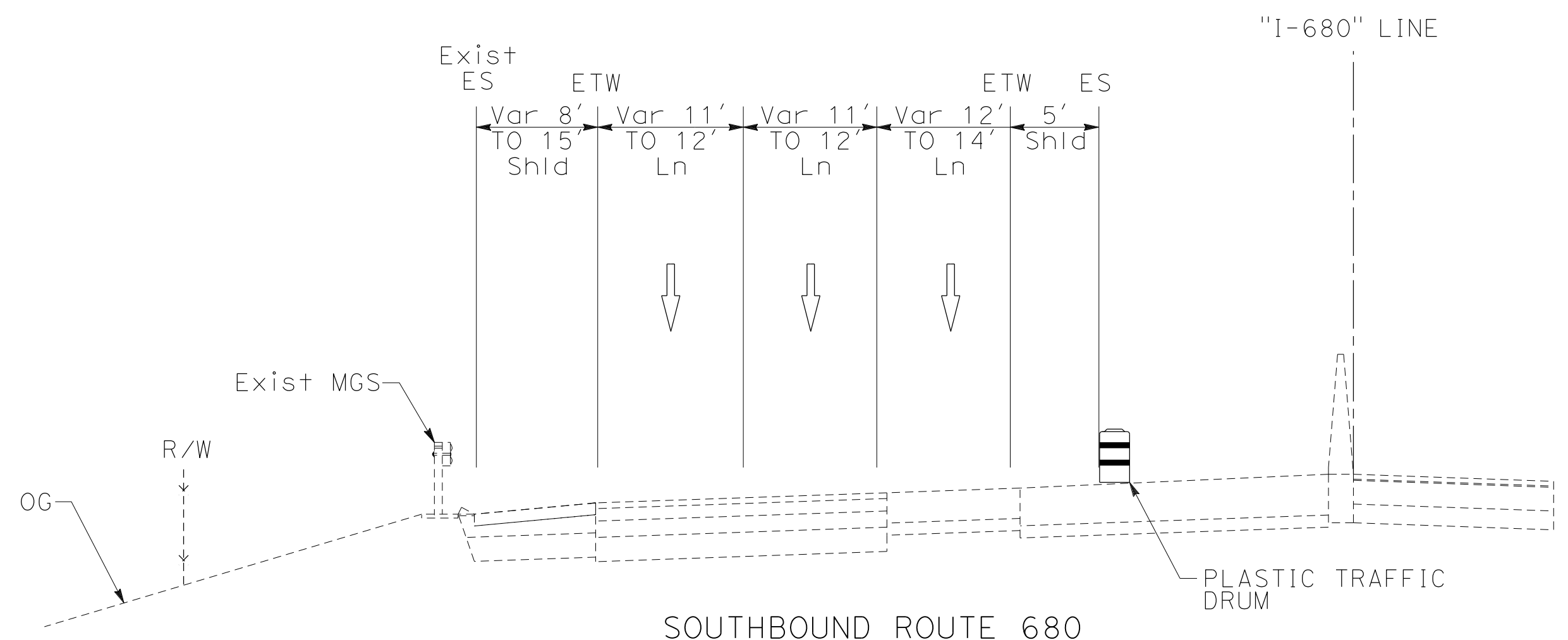

SOUTHBOUND ROUTE 680  
**SECTION O-O**

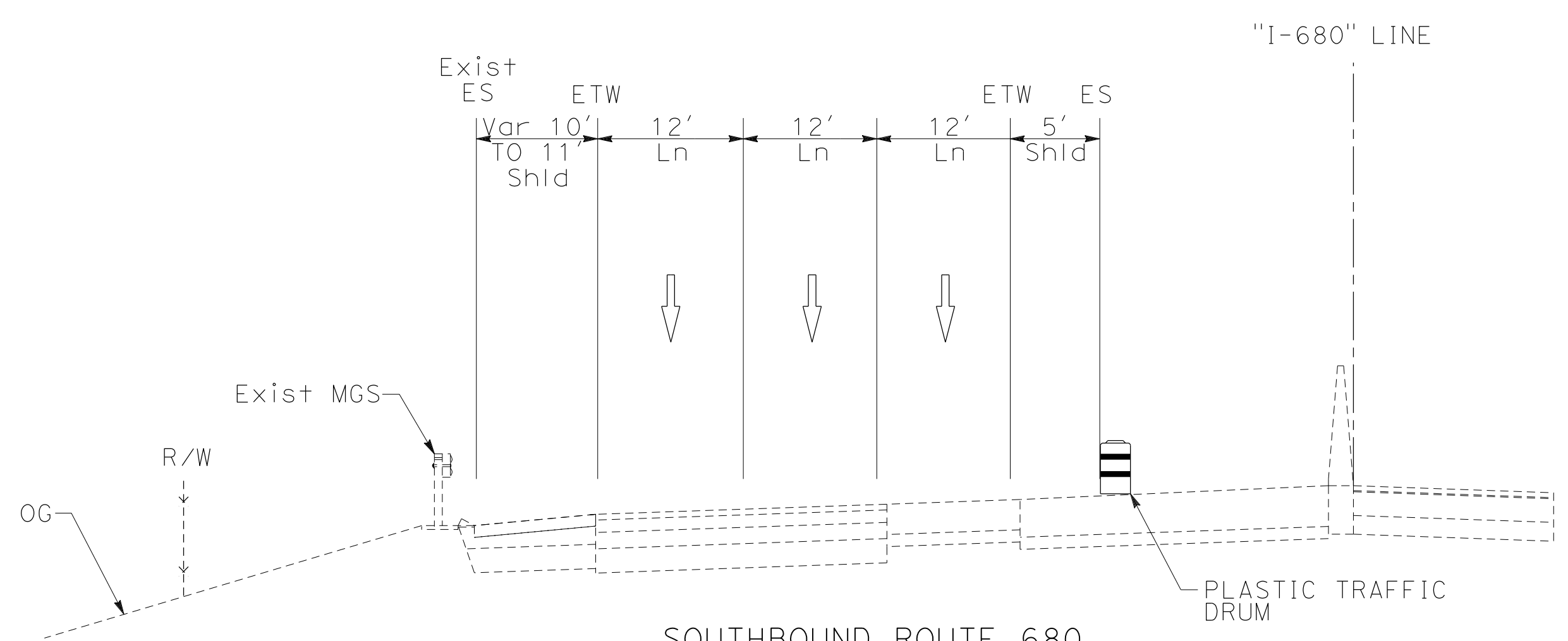

SOUTHBOUND ROUTE 680  
**SECTION N-N**



**STAGE CONSTRUCTION  
AND TRAFFIC HANDLING PLAN  
STAGE 4**

NO SCALE

**SC-184**

FOR NOTES, ABBREVIATIONS AND  
LEGEND, SEE SHEET SC-1 AND SC-186

X:\680\_SB\_GAP\_EXPRESS\000\_CAD\Submit\11\11\CADD\_sub\11\11\0420000235ma184.dgn  
 STATE OF CALIFORNIA - DEPARTMENT OF TRANSPORTATION  
 CONSULTANT FUNCTIONAL SUPERVISOR  
 JAMEY VALDIVIA  
 ERIN MCPHERSON  
 REVISOR  
 JAMES VALDIVIA  
 ERIN MCPHERSON  
 CHECKED BY  
 TIMOTHY J. LEE  
 SUPERVISOR  
 JAMES VALDIVIA  
 ERIN MCPHERSON  
 DATE  
 9-29-21  
 DATE  
 9-29-21

Dist	COUNTY	ROUTE	POST MILES TOTAL PROJECT	SHEET No.	TOTAL SHEETS
04	Ala, CC	680	R11.0/R21.9, RO.0/RO.9	698	1710
 REGISTERED CIVIL ENGINEER			9-29-21	DATE	
October 8, 2021 PLANS APPROVAL DATE					
<small>THE STATE OF CALIFORNIA OR ITS OFFICERS OR AGENTS SHALL NOT BE RESPONSIBLE FOR THE ACCURACY OR COMPLETENESS OF SCANNED COPIES OF THIS PLAN SHEET.</small>					
WMH CORPORATION 55 South Market St Suite 1200 San Jose, CA 95113			ALAMEDA CTC 1111 Broadway Suite 800 Oakland, CA 94607		

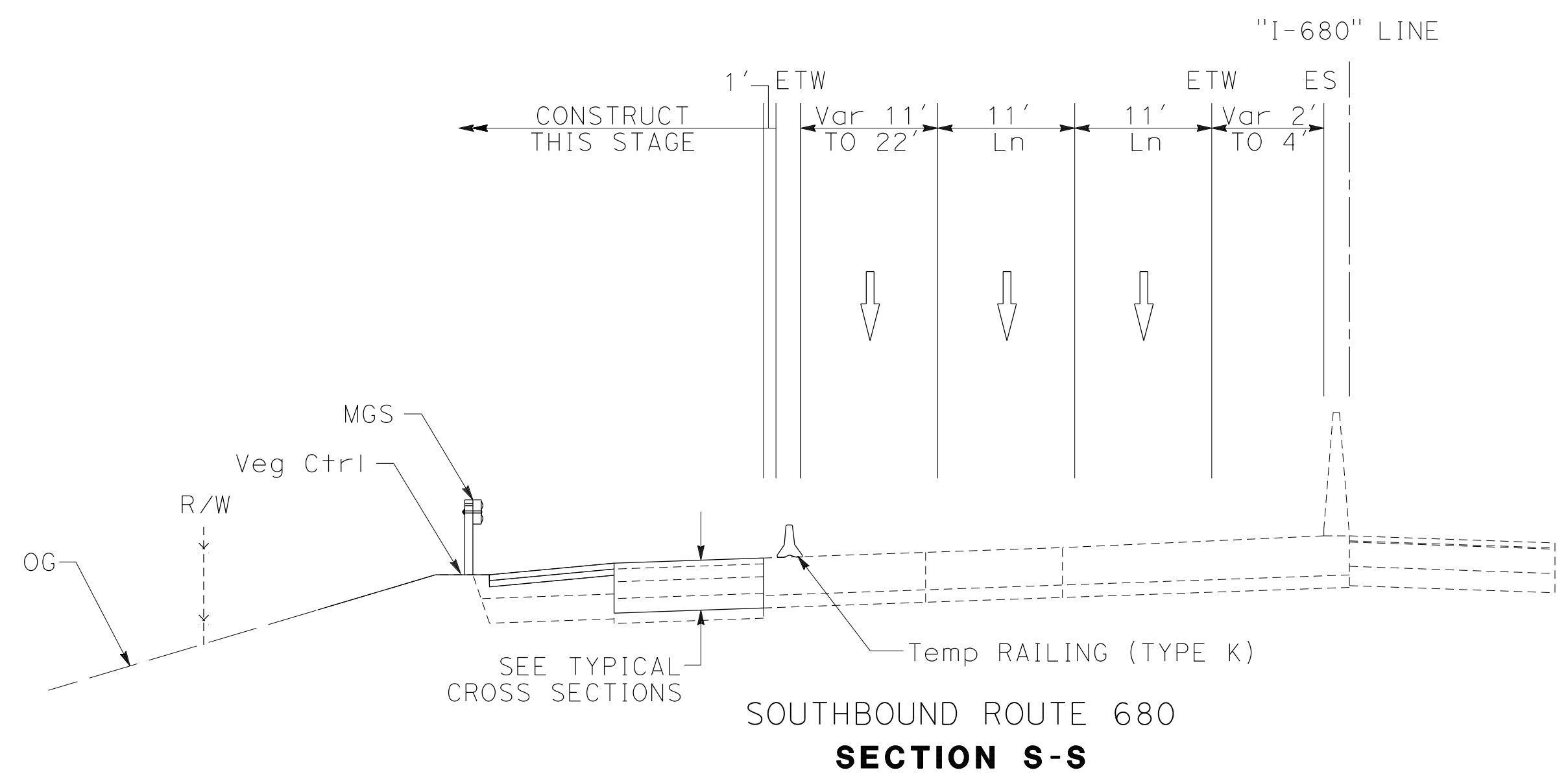
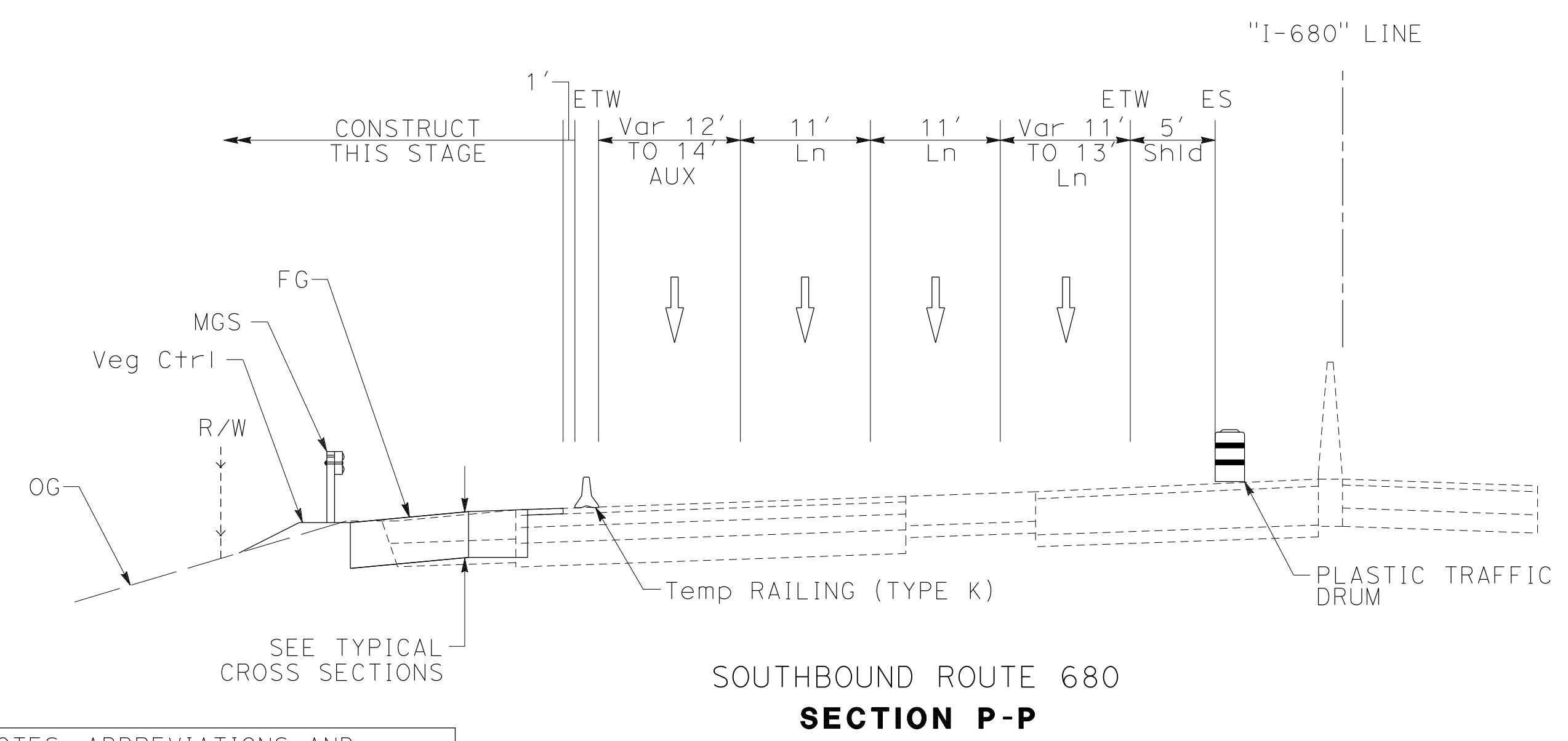
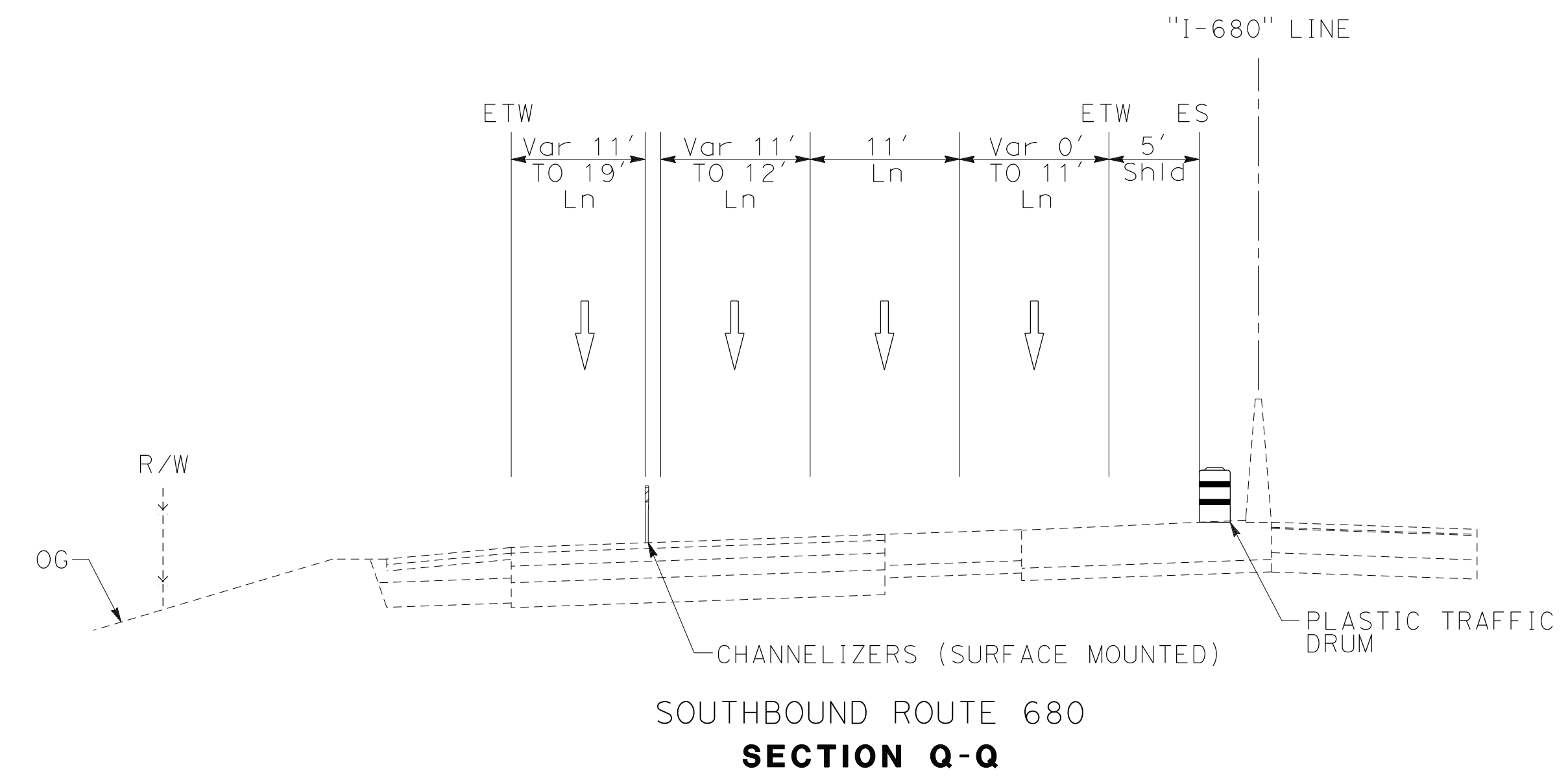
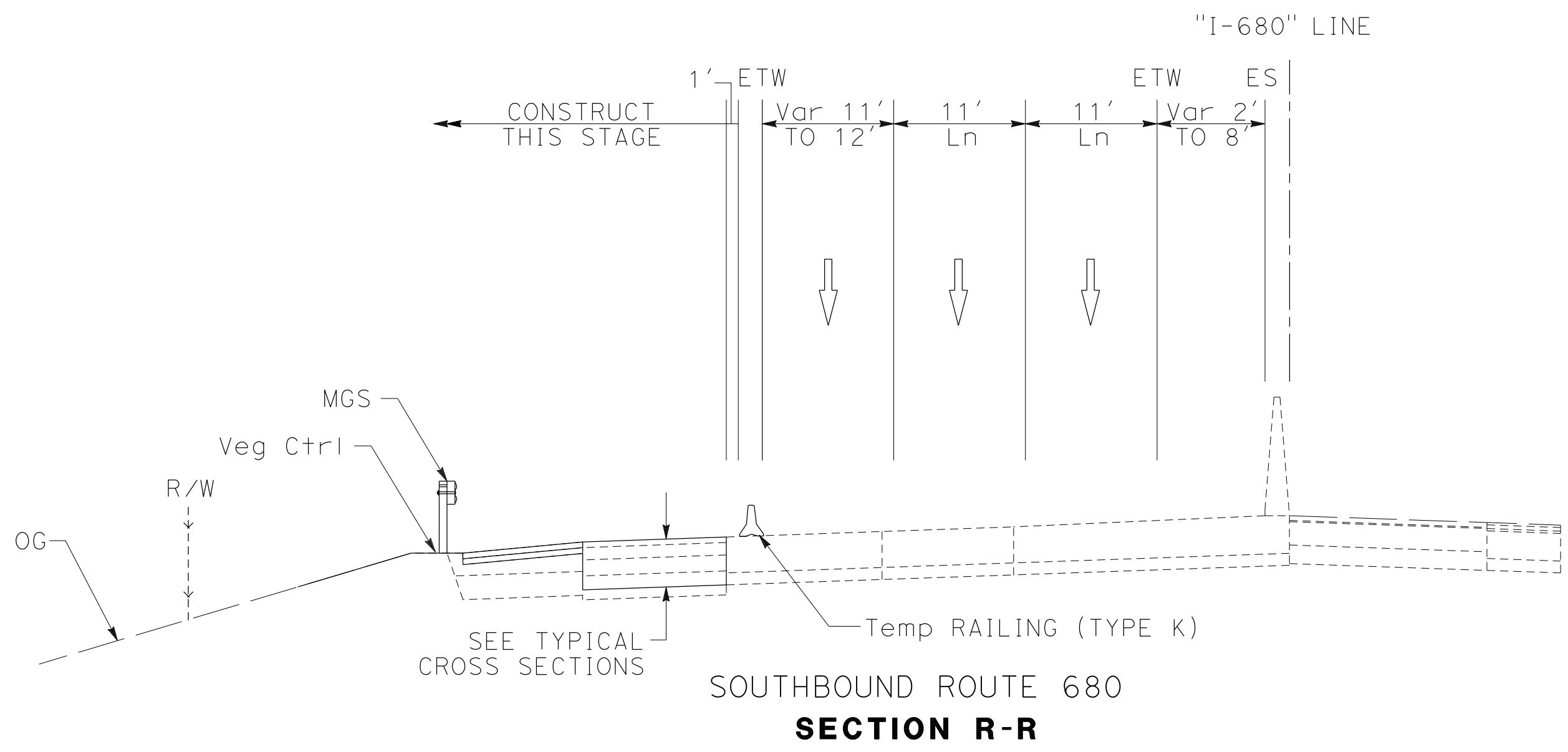

## STAGE CONSTRUCTION AND TRAFFIC HANDLING PLAN STAGE 4

NO SCALE

**SC-185**

FOR NOTES, ABBREVIATIONS AND LEGEND, SEE SHEET SC-1 AND SC-186

X:\680\_SB\_EXPRESS\000\_CAD\Submittal\CADD\_submittal\0420000235ma185.dgn  
 STATE OF CALIFORNIA - DEPARTMENT OF TRANSPORTATION  
 CONSULTANT: JAMEY VALDIVIA, ERIN MCPHERSON  
 CALCULATED/DESIGNED BY: JAMES VALDIVIA, ERIN MCPHERSON  
 CHECKED BY: ERIN MCPHERSON  
 SUPERVISOR: TIMOTHY J. LEE  
 REVISIONS: 9-29-21

Dist	COUNTY	ROUTE	POST MILES TOTAL PROJECT	SHEET No.	TOTAL SHEETS
04	Ala, CC	680	R11.0/R21.9, RO.0/RO.9	699	1710

	9-29-21 REGISTERED CIVIL ENGINEER DATE
October 8, 2021 PLANS APPROVAL DATE	
<small>THE STATE OF CALIFORNIA OR ITS OFFICERS OR AGENTS SHALL NOT BE RESPONSIBLE FOR THE ACCURACY OR COMPLETENESS OF SCANNED COPIES OF THIS PLAN SHEET.</small>	
WMH CORPORATION 55 South Market St Suite 1200 San Jose, CA 95113	ALAMEDA CTC 1111 Broadway Suite 800 Oakland, CA 94607

**NOTES:**

- FOR ACCURATE RIGHT OF WAY DATA, CONTACT RIGHT OF WAY ENGINEERING AT THE DISTRICT OFFICE.
- MAY REQUIRE 10' Temp RAILING (TYPE K).

**STAGE 4 CONSTRUCTION:**

- CONSTRUCT P/JPC LANE REHABILITATION, PROPOSED DRAINAGE, SHOULDER REHABILITATION, SHOULDER WIDENING, MGS PLACEMENT, AND GRADING.
- CONSTRUCT RAMP WIDENING.

**STAGE 4 TRAFFIC:**

- SHIFT TRAFFIC TOWARD THE MEDIAN ON SB 680 AS SHOWN, MAINTAINING EXISTING NUMBER OF LANES.
- SHIFT RAMP TRAFFIC AS SHOWN ONTO TEMPORARY PAVEMENT.

**STAGE 4 DRAINAGE:**

CONSTRUCT DRAINAGE SYSTEM ALONG L+ ES  
 STA "SKP" 163+00 TO "I-680" 303+00  
 STA "SS" 313+00 TO "SS" 318+00  
 STA "ST" 312+00 TO "ST" 320+00, CONSTRUCT UNDER NIGHT CLOSURE  
 STA "I-680" 322+00 TO "I-680" 337+00

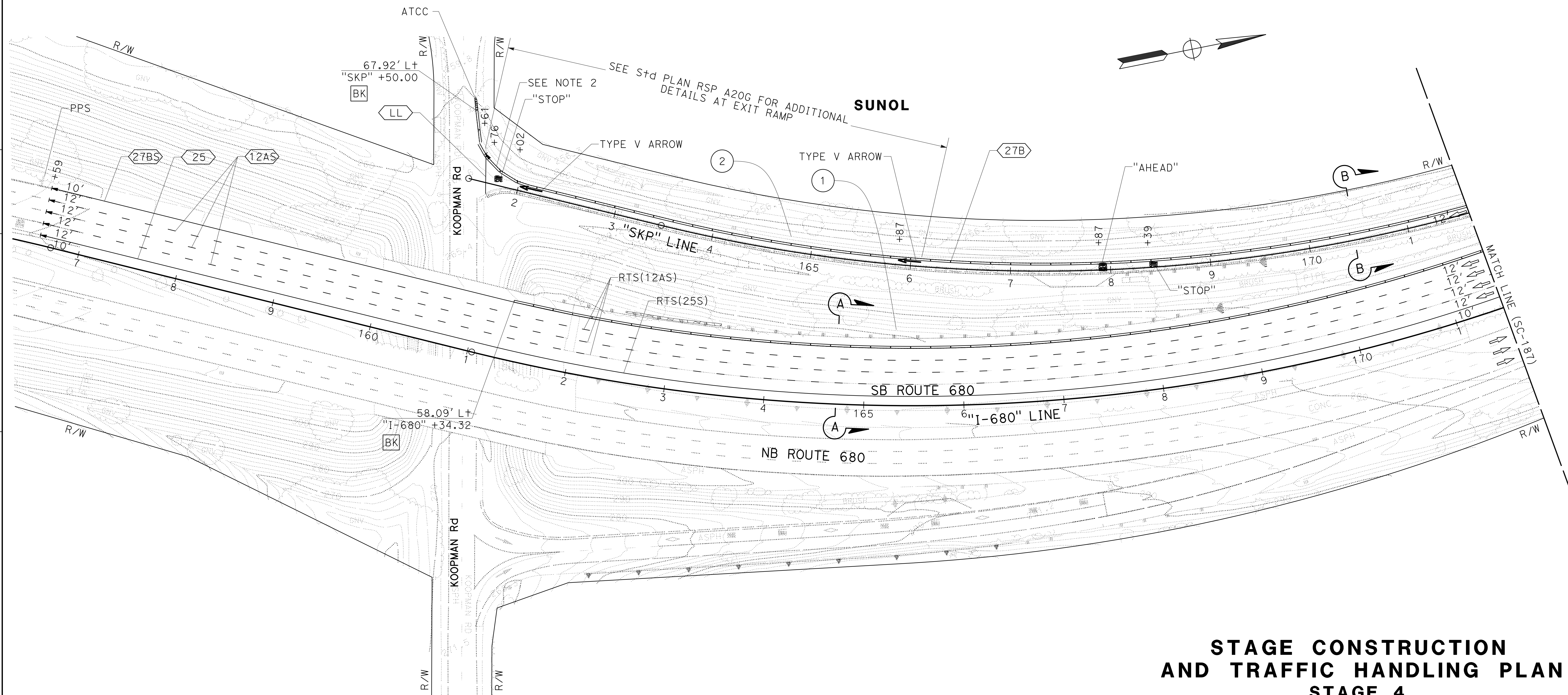

FOR NOTES, ABBREVIATIONS AND LEGEND, SEE SHEET SC-1

APPROVED FOR STAGE CONSTRUCTION AND TRAFFIC HANDLING WORK ONLY

**STAGE CONSTRUCTION AND TRAFFIC HANDLING PLAN STAGE 4**

SCALE: 1" = 50'

**SC-186**

STATE OF CALIFORNIA - DEPARTMENT OF TRANSPORTATION	CONSULTANT	FUNCTIONAL SUPERVISOR	CHECKED BY	DESIGNED BY	REVISIONS
	TIMOTHY J. LEE	JAMEY VALDIVIA	ERIN MCPHERSON	JV	9-29-21

Dist	COUNTY	ROUTE	POST MILES TOTAL PROJECT	SHEET No.	TOTAL SHEETS
04	Ala, CC	680	R11.0/R21.9, RO.0/RO.9	700	1710
			9-29-21		
REGISTERED CIVIL ENGINEER			DATE		
			October 8, 2021		
			PLANS APPROVAL DATE		
<small>THE STATE OF CALIFORNIA OR ITS OFFICERS OR AGENTS SHALL NOT BE RESPONSIBLE FOR THE ACCURACY OR COMPLETENESS OF SCANNED COPIES OF THIS PLAN SHEET.</small>					
WMH CORPORATION 55 South Market St Suite 1200 San Jose, CA 95113			ALAMEDA CTC 1111 Broadway Suite 800 Oakland, CA 94607		



NOTE:  
FOR ACCURATE RIGHT OF WAY DATA, CONTACT  
RIGHT OF WAY ENGINEERING AT THE DISTRICT OFFICE.

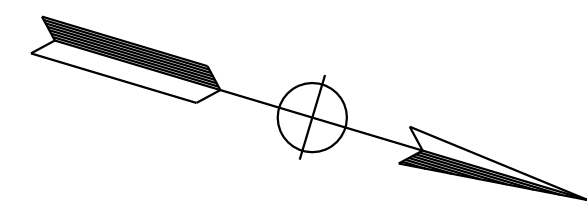

REVISOR	DATE	REVISION
JV	9-29-21	
CALCULATED/DESIGNED BY: JAMEY VALDIVIA CHECKED BY: ERIN MCPHERSON CONSULTANT: TIMOTHY J. LEE SUPERVISOR:		
STATE OF CALIFORNIA - DEPARTMENT OF TRANSPORTATION 		

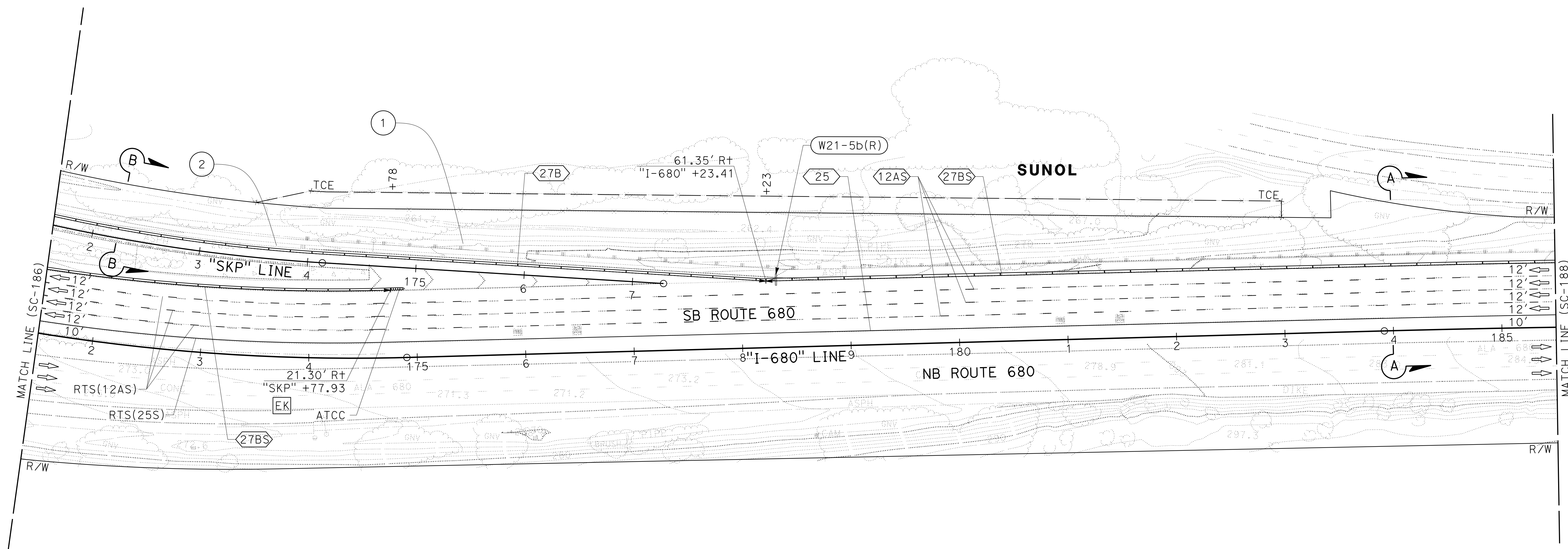

FOR NOTES, ABBREVIATIONS AND  
LEGEND, SEE SHEET SC-1 AND SC-186

APPROVED FOR STAGE CONSTRUCTION AND TRAFFIC HANDLING WORK ONLY

## STAGE CONSTRUCTION AND TRAFFIC HANDLING PLAN STAGE 4

SCALE: 1" = 50'

**SC-187**

LAST REVISION: 09-29-21 10:14    DATE PLOTTED => 8-MAR-2022    TIME PLOTTED => 10:14